

NOTES:

1. MATERIAL - PP8
2. ALL DIMENSIONS ARE IN MILLIMETERS.
3. TOLERANCES - X.X=±0.25  
-X.XX=±0.13  
UNLESS OTHERWISE SPECIFIED.
4. ESD - SURFACE RESISTIVITY  
- 10<sup>5</sup> TO 10<sup>11</sup> OHMS/SQ.
5. FOR PACKAGE - 1.4 MM THICKNESS.
6. PART NO. : ND 1414 1.4 0615 8 REV.A  
(PLEASE INDICATE ON PURCHASE ORDER).
7. DATECODE AT TRAY BOTTOM SIDE.

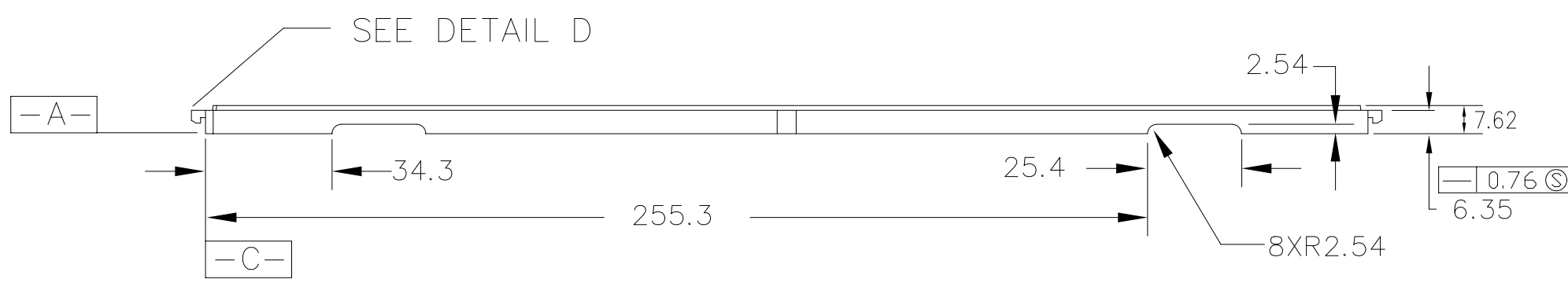

REV.NO.	ECN #	DESCRIPTION	DATE
19	P-00953	CHANGE FROM TQFP TO QFP	10 AUG 99
18	P-00889	CHANGE SURFACE RESISTIVITY	1 FEB 99
17	P-00767	ADD RUNNER GATE	30 SEP 98
16	P-00630	CHANGE POSITION TOL	24 SEP 97
15	P-00552	ADD DETAIL S AS MARKING	15 SEP 95
14	P-00542	DELETED "ASSEMBLED IN SINGAPORE"	1 SEP 95

THIS DOCUMENT CONTAINS INFORMATION PROPRIETARY TO PEAK PLASTIC & METAL PRODUCTS INTERNATIONAL LIMITED. REPRODUCTION, DISCLOSURE OR USE OF THIS DOCUMENT IS EXPRESSLY PROHIBITED EXCEPT IF OTHERWISE AGREED UPON IN WRITING.

DRAWN BY :	BUSH	PAGE 1 OF 2
CHECKED BY :	WILDER	DATE : 10 AUG 99
APPROVED BY :	JONES	DATE : 10 AUG 99
APPROVED BY :	DAVY	DATE : 10 AUG 99
DO NOT SCALE DRAWING		CODE : CSA00609



**PEAK** PLASTIC & METAL PRODUCTS INT'L LTD.

CUSTOMER : **PEAK**

TITLE : ND 1414 1.4 0615 8 REV.A

DWG NO.:ND 1414 1.4 0615 8 REV.A      REV. 19

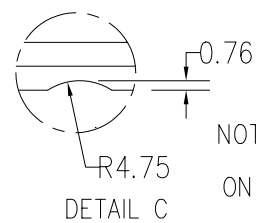
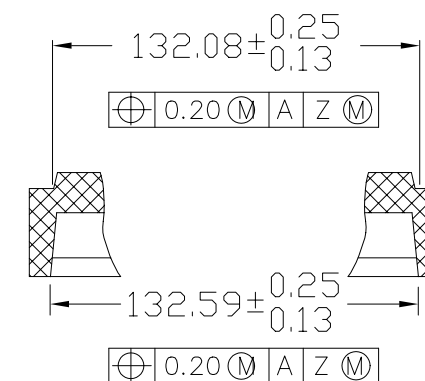
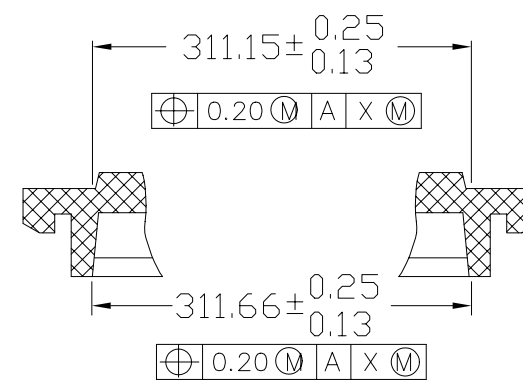
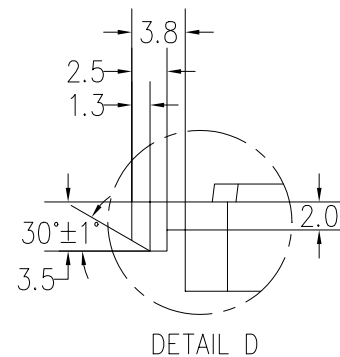
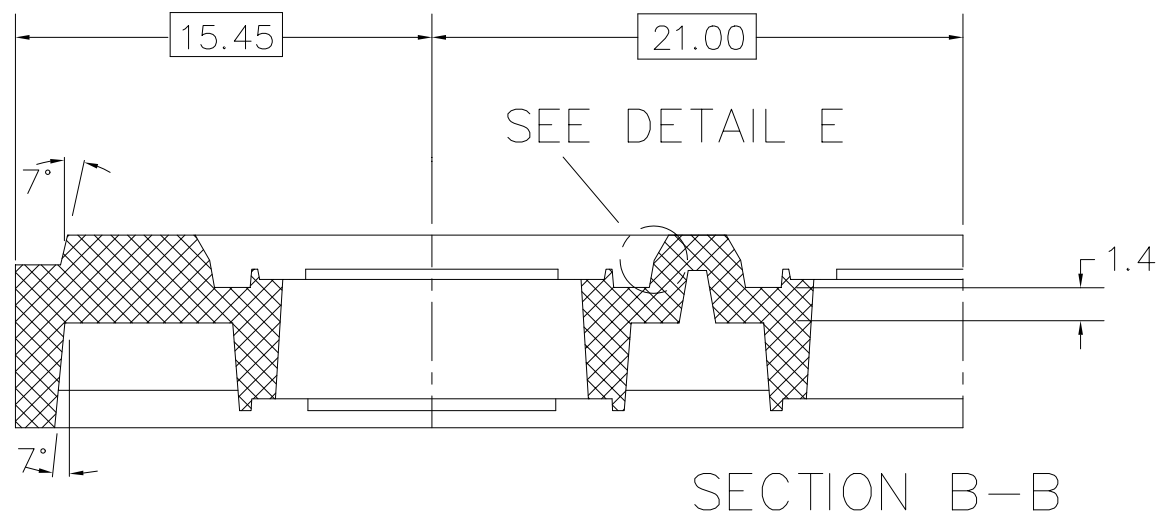
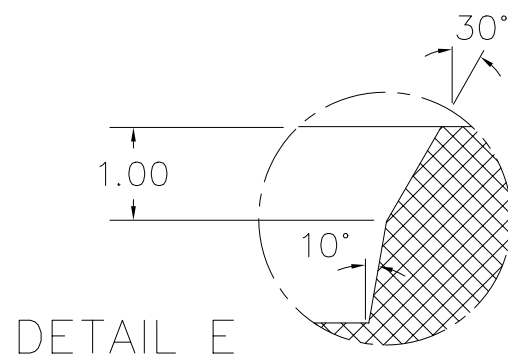
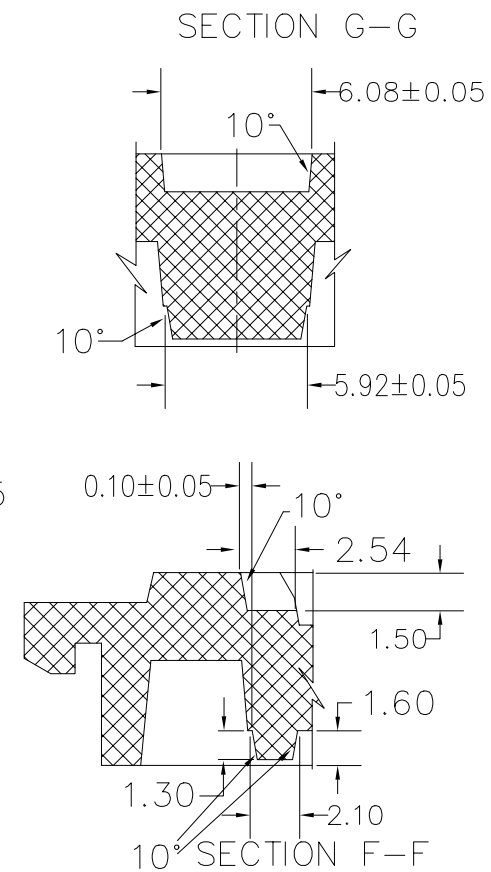
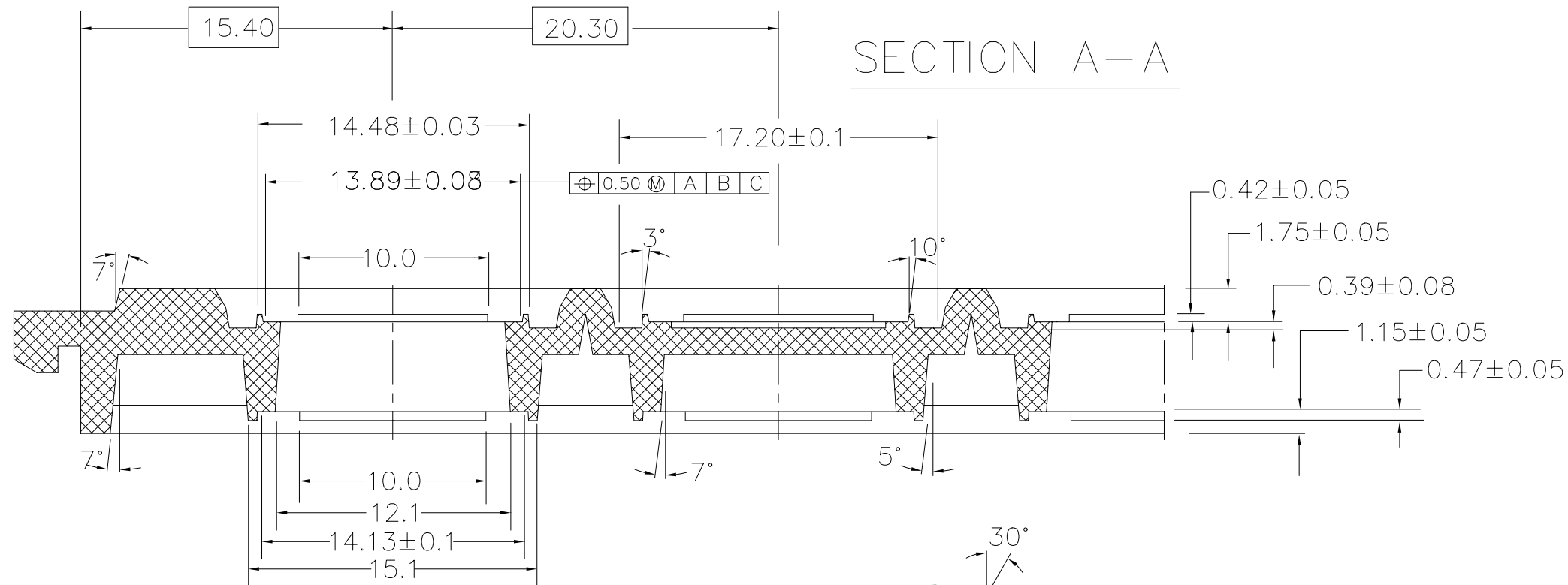
PEAK



NOTE: SCALLOP IS CENTERED ON SIDE OF TRAY



**PEAK** PEAK PLASTIC & METAL PRODUCTS INT'L LTD.

REV.NO.	ECN #	DESCRIPTION	DATE
19	P-00953	CHANGE FROM TQFP TO QFP	10 AUG 99
18	P-00889	CHANGE SURFACE RESISTIVITY	1 FEB 99
17	P-00767	ADD RUNNER GATE	30 SEP 98
16	P-00630	CHANGE POSITION TOL	24 SEP 97
15	P-00552	ADD DETAIL S AS MARKING	15 SEP 95
14	P-00542	DELETED "ASSEMBLED IN SINGAPORE"	1 SEP 95

THIS DOCUMENT CONTAINS INFORMATION PROPRIETARY TO PEAK PLASTIC & METAL PRODUCTS INTERNATIONAL LIMITED. REPRODUCTION, DISCLOSURE OR USE OF THIS DOCUMENT IS EXPRESSLY PROHIBITED EXCEPT IF OTHERWISE AGREED UPON IN WRITING.

DRAWN BY :	BUSH	PAGE 2 OF 2
CHECKED BY :	WILDER	DATE : 10 AUG 99
APPROVED BY :	JONES	DATE : 10 AUG 99
APPROVED BY :	DAVY	DATE : 10 AUG 99
DO NOT SCALE DRAWING		CODE : CSA00609

CUSTOMER :	PEAK
TITLE :	ND 1414 1.4 0615 8 REV.A
DWG NO.:	ND 1414 1.4 0615 8 REV.A
REV.	19