

C-15/13-DXX-BX-SSCX-XX

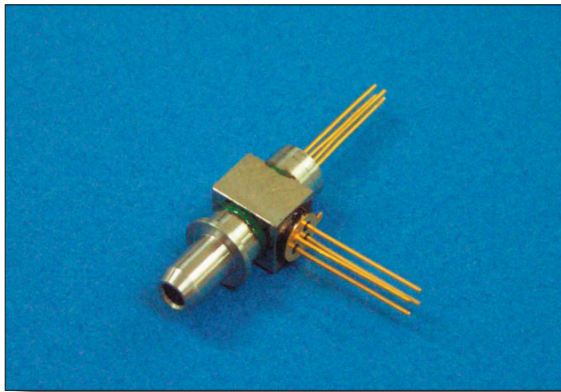

Features

- Single fiber bi-directional operation
- Laser diode with multi-quantum- well structure
- Low threshold current
- InGaAs/InP PIN Photodiode with trans-impedance amplifier
- High sensitivity with AGC*
- Differential ended output
- Single +3.3V Power Supply
- Integrated WDM coupler
- Un-cooled operation from 0°C to +70°C
- Hermetically sealed active component
- SC receptacle package
- Design for fiber optic networks
- RoHS Compliant available

Absolute Maximum Rating (Tc=25°C)

Parameter	Symbol	Value	Unit
Fiber Output Power L/M/H	P_f	0.6(L) / 1(M) / 2(H)	mW
LD Reverse Voltage	V_{RLD}	2	V
PIN-TIA Voltage	V_{CC}	4.5	V
Operating Temperature	T_{opr}	0 ~ +70	°C
Storage Temperature	T_{stg}	-40 ~ +85	°C

(All optical data refer to a coupled 9/125µm SM fiber)

Optical and Electrical Characteristics(Tc=25°C)

Parameter	Symbol	Min	Typical	Max	Unit	Test Condition
Laser Diode						
Optical Output Power	L M H	0.2 0.5 1	- - 1.6	0.5 1 -	mW	CW, $I_{th}+ 30mA$, kink free
Peak Wavelength	λ	1535	1550	1565	nm	CW, $P_f=P_f(\text{Min})$
Side mode Supperssion	$\Delta\lambda$	30	35	-	nm	CW, $P_f=P_f(\text{Min}), 0\sim 70^\circ\text{C}$
Threshold Current	I_{th}	-	10	15	mA	CW
Forward Voltage	V_f	-	1.2	1.5	V	CW, $P_f=P_f(\text{Min})$
Rise/Fall Time	t_r/ t_f	-	-	0.3	ns	$I_{bias}=I_{th}$, 10% ~ 90%
Monitor Diode						
Monitor Current	I_m	100	-	-	µA	CW, $P_f=P_f(\text{Min}), V_{RPD}=2V$
Dark Current	I_{DARK}	-	-	0.1	µA	$V_{RPD}=5V$
Capacitance	C_t	-	6	15	pF	$V_{RPD}=5V, f=1\text{MHz}$
Module						
Tracking Error	$\Delta P_f/P_f$	-1.5	-	1.5	dB	APC, 0 ~ +70°C
Optical Crosstalk	CRT		< -45		dB	

Note:

- 1.Pin assignment can be customized.
- 2.Specifications subject to change without notice.

C-15/13-DXX-BX-SSCX-XX

Detector $\lambda=1100\sim 1430\text{nm}$

DC Electrical Characteristics($T_c=25^\circ\text{C}$)

Parameter	Symbol	Min	Typical	Max	Unit	Test Condition	
Power Supply	V_{cc}	3.0	3.3	3.6	V		
Differential Output Voltage	V_d	D02	-	-	1000	mV	
		D04	-	260	450		
		D06	185	250	415		
Supply Current (no load)	I_{cc}	D02	-	-	35	mA	
		D04	-	21	30		
		D06	-	26	50		

AC/Optical and Electrical Characteristics($T_c=25^\circ\text{C}$)

Parameter	Symbol	Min	Typical	Max	Unit	Test Condition	
Detection Range		1100	1310	1430	nm	-	
Gain @ 10 Mbps Differential	G	D02	52	-	70	V/mW	Measure differentially, AC coupled, $R_L=50\Omega$ Measure differentially, AC coupled, $R_L=50\Omega$ Measure differentially with 30uAp-p signal
		D04	6	7	-		
		D06	1.92	2.5	3.4		
Bandwidth	BW	D02	120	140	-	MHz	
		D04	404	470	-		
		D06	700	920	1100		
Saturation Power	P _{sat}	D02	-3	0	-	dBm	BER<10 ⁻¹⁰ @155Mbps PRBS 2 ²³ -1,Er=10dB BER<10 ⁻¹⁰ @622Mbps PRBS 2 ²³ -1,Er=10dB BER<10 ⁻¹² @1.25Gbps PRBS 2 ⁷ -1,Er=10dB
		D04	-7	-6	-		
		D06	-3	-	-		
Sensitivity	Sens.	D02	-	-38	-35	dBm	BER<10 ⁻¹⁰ @155Mbps PRBS 2 ²³ -1,Er=10dB BER<10 ⁻¹⁰ @622Mbps PRBS 2 ²³ -1,Er=10dB BER<10 ⁻¹² @1.25Gbps PRBS 2 ⁷ -1,Er=10dB
		D04	-	-33	-30		
		D06	-	-26	-23		
Output Resistance	R _{out}	D02	-	50	-	ohm	
		D04	48	50	52		
		D06	48	50	62		

C-15/13-DXX-BX-SSCX-XX

Pin Assignment

Units in mm.

Part Number: C-15/13-DXX-BX-SSCX-XX

LD Pin Assignment

A Type

- Pin 1 : Laser Cathode
- Pin 2 : Laser Anode and Case Gnd
- Pin 3 : Monitor Diode Anode
- Pin 4 : Monitor Diode Cathode

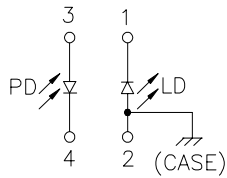

D Type

- Pin 1 : Laser Anode and Monitor Diode Cathode
- Pin 2 : Case Gnd
- Pin 3 : Laser Cathode
- Pin 4 : Monitor Diode Anode

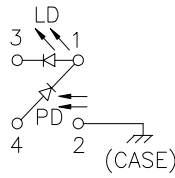

PIN-TIA Pin Assignment

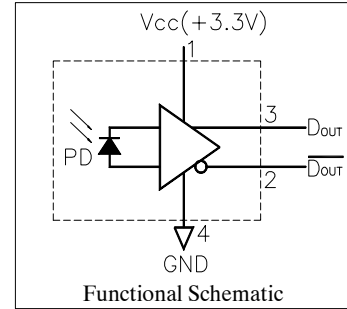

Outline Dimensions

Units in mm.

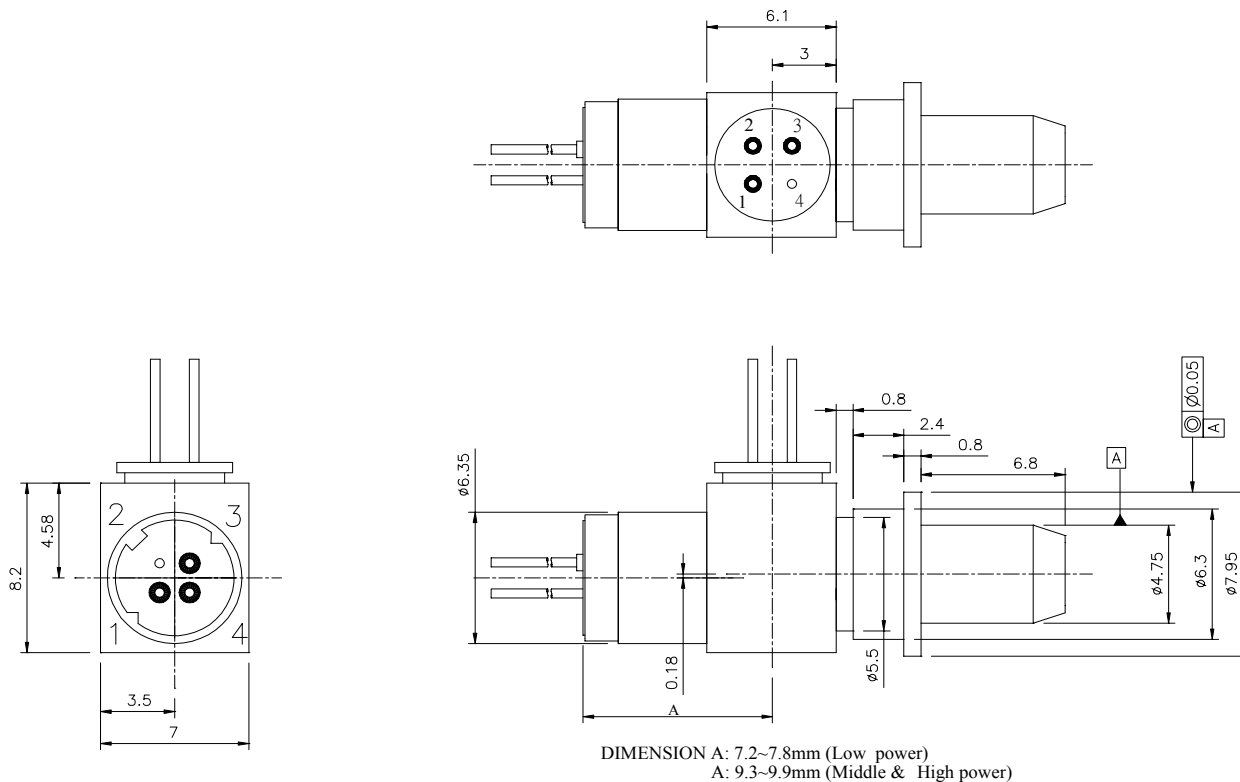

Ordering Information

C-15/13-DXX-BX-SSCX-XX

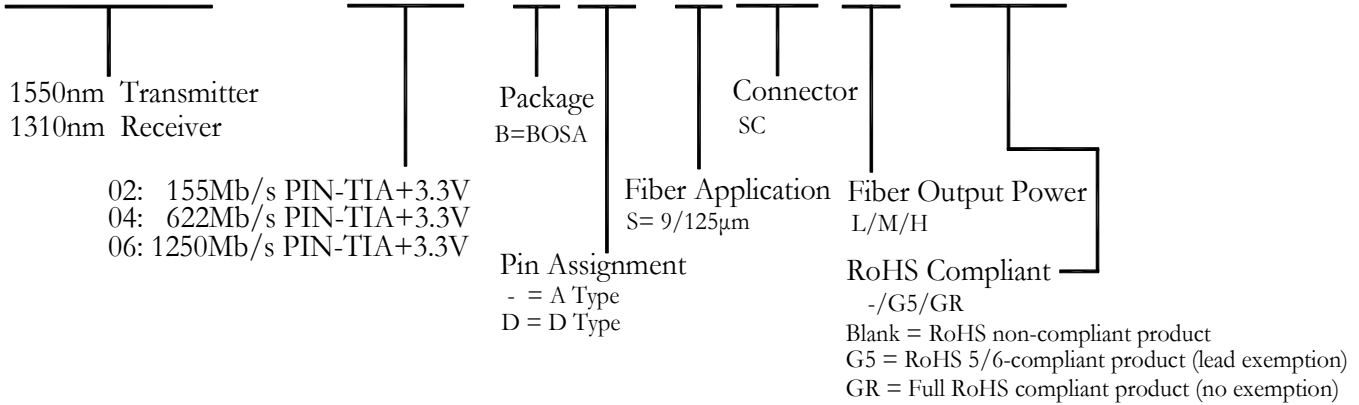

Warnings

Handling Precautions: This device is susceptible to damage as a result of electrostatic discharge (ESD). A static free environment is highly recommended. Follow guidelines according to proper ESD procedures.
Laser Safety: Radiation emitted by laser devices can be dangerous to human eyes. Avoid eye exposure to direct or indirect radiation.

Legal Notice

IMPORTANT NOTICE!
All information contained in this document is subject to change without notice, at LuminentOIC's sole and absolute discretion. LuminentOIC warrants performance of its products to current specifications only in accordance with the company's standard one-year warranty; however, specifications designated as "preliminary" are given to describe components only, and LuminentOIC expressly disclaims any and all warranties for said products, including express, implied, and statutory warranties, warranties of merchantability, fitness for a particular purpose, and non-infringement of proprietary rights. Please refer to the company's Terms and Conditions of Sale for further warranty information.

LuminentOIC assumes no liability for applications assistance, customer product design, software performance, or infringement of patents, services, or intellectual property described herein. No license, either express or implied, is granted under any patent right, copyright, or intellectual property right, and LuminentOIC makes no representations or warranties that the product(s) described herein are free from patent, copyright, or intellectual property rights. Products described in this document are NOT intended for use in implantation or other life support applications where malfunction may result in injury or death to persons. LuminentOIC customers using or selling products for use in such applications do so at their own risk and agree to fully defend and indemnify LuminentOIC for any damages resulting from such use or sale.

THE INFORMATION CONTAINED IN THIS DOCUMENT IS PROVIDED ON AN "AS IS" BASIS. Customer agrees that LuminentOIC is not liable for any actual, consequential, exemplary, or other damages arising directly or indirectly from any use of the information contained in this document. Customer must contact LuminentOIC to obtain the latest version of this publication to verify, before placing any order, that the information contained herein is current.

© LuminentOIC, Inc. 2006
All rights reserved