

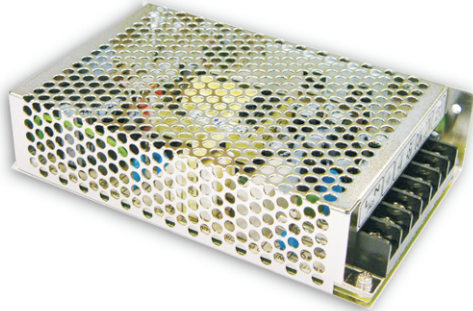

75W Triple Output Switching Power Supply

NET-75 series



■ Features :

- Universal AC input / Full range
- Protections: Short circuit / Over load / Over voltage
- Cooling by free air convection
- 100% full load burn-in test
- 2 years warranty



SPECIFICATION

MODEL		NET-75A			NET-75B			NET-75C			NET-75D		
OUTPUT	OUTPUT NUMBER	CH1	CH2	CH3	CH1	CH2	CH3	CH1	CH2	CH3	CH1	CH2	CH3
	DC VOLTAGE	5V	12V	-5V	5V	12V	-12V	5V	15V	-15V	5V	24V	12V
	RATED CURRENT	6A	3A	0.5A	5A	2.8A	0.5A	6A	2.3A	0.5A	5A	1.5A	1A
	CURRENT RANGE <small>Note.6</small>	0.6 ~ 7A	0.2 ~ 3.5A	0.1 ~ 0.7A	0.6 ~ 7A	0.2 ~ 3.5A	0.1 ~ 0.7A	0.6 ~ 7A	0.1 ~ 3.5A	0.1 ~ 0.7A	0.6 ~ 6A	0.1 ~ 2A	0.1 ~ 1.5A
	RATED POWER	68.5W			64.6W			72W			73W		
	RIPPLE & NOISE (max.) <small>Note.2</small>	80mVp-p	120mVp-p	120mVp-p	80mVp-p	120mVp-p	120mVp-p	80mVp-p	150mVp-p	150mVp-p	80mVp-p	200mVp-p	120mVp-p
	VOLTAGE ADJ. RANGE	CH1:4.75 ~ 5.5V			CH1: 4.75 ~ 5.5V			CH1: 4.75 ~ 5.5V			CH1: 4.75 ~ 5.5V		
	VOLTAGE TOLERANCE <small>Note.3</small>	±2.0%	±6.0%	±5.0%	±2.0%	±6.0%	±5.0%	±2.0%	±8.0%	±5.0%	±2.0%	±8.0%	±6.0%
	LINE REGULATION <small>Note.4</small>	±0.5%	±1.0%	±1.0%	±0.5%	±1.0%	±1.0%	±0.5%	±1.0%	±1.0%	±0.5%	±1.0%	±1.0%
	LOAD REGULATION <small>Note.5</small>	±1.5%	±3.0%	±1.0%	±1.5%	±3.0%	±1.0%	±1.5%	±3.0%	±1.0%	±1.5%	±3.0%	±3.0%
SETUP, RISE TIME	500ms, 30ms/230VAC			1200ms, 30ms/115VAC at full load									
HOLD UP TIME (Typ.)	50ms/230VAC			10ms/115VAC at full load									
INPUT	VOLTAGE RANGE	85 ~ 264VAC			120 ~ 370VDC								
	FREQUENCY RANGE	47 ~ 63Hz											
	EFFICIENCY(Typ.)	77%			78%			78%			80%		
	AC CURRENT (Typ.)	1.5A/115VAC			0.9A/230VAC								
	INRUSH CURRENT (Typ.)	COLD START 45A											
	LEAKAGE CURRENT	<2mA / 240VAC											
PROTECTION	OVERLOAD	110 ~ 150% rated output power Protection type : Hiccup mode, recovers automatically after fault condition is removed											
	OVER VOLTAGE	CH1: 5.75 ~ 6.75V Protection type : Shut down o/p voltage, re-power on to recover											
ENVIRONMENT	WORKING TEMP.	-20 ~ +60°C (Refer to output load derating curve)											
	WORKING HUMIDITY	20 ~ 90% RH non-condensing											
	STORAGE TEMP., HUMIDITY	-40 ~ +85°C, 10 ~ 95% RH											
	TEMP. COEFFICIENT	±0.03%/°C (0 ~ 45°C)											
	VIBRATION	10 ~ 500Hz, 2G 10min./1cycle, period for 60min. each along X, Y, Z axes											
SAFETY & EMC <small>(Note 6)</small>	SAFETY STANDARDS	UL60950-1, CB(IEC60950-1) Approved											
	WITHSTAND VOLTAGE	I/P-O/P:3KVAC I/P-FG:1.5KVAC O/P-FG:0.5KVAC											
	ISOLATION RESISTANCE	I/P-O/P, I/P-FG, O/P-FG:100M Ohms/500VDC											
	EMI CONDUCTION & RADIATION	Compliance to EN55022 (CISPR22) Class B											
	HARMONIC CURRENT	Compliance to EN61000-3-2,-3											
EMS IMMUNITY	Compliance to EN61000-4-2, 3, 4, 5, 6, 8, 11, ENV50204, EN55024, EN61000-6-1 Light industry level, criteria A												
OTHERS	MTBF	361.6K hrs min. MIL-HDBK-217F (25°C)											
	DIMENSION	159*97*38mm (L*W*H)											
	PACKING	0.52Kg; 30pcs/16.6Kg/0.97CUFT											
NOTE	<ol style="list-style-type: none"> 1. All parameters NOT specially mentioned are measured at 230VAC input, rated load and 25°C of ambient temperature. 2. Ripple & noise are measured at 20MHz of bandwidth by using a 12" twisted pair-wire terminated with a 0.1uF & 47uF parallel capacitor. 3. Tolerance : includes set up tolerance, line regulation and load regulation. 4. Line regulation is measured from low line to high line at rated load. 5. Load regulation is measured from 20% to 100% rated load, and other output at 60% rated load. 6. Each output can work within current range. But total output power can't exceed rated output power. 7. The power supply is considered a component which will be installed into a final equipment. The final equipment must be re-confirmed that it still meets EMC directives. 												

Mechanical Specification

Case No. 901 Unit:mm

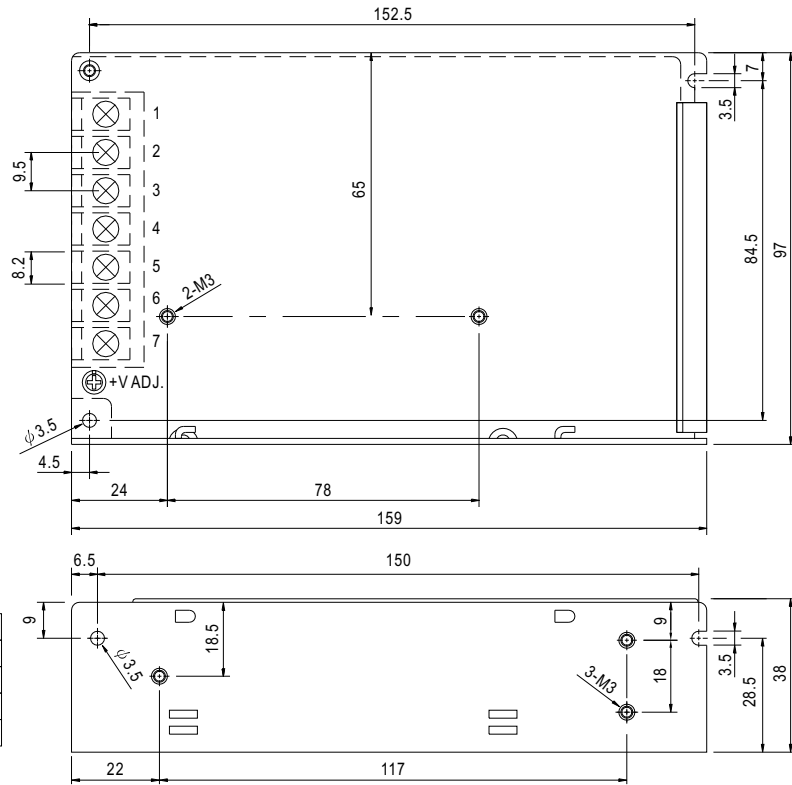

Terminal Pin. No Assignment

Pin No.	Assignment	Pin No.	Assignment
1	AC/L	5	DC OUTPUT +V2
2	AC/N	6	DC OUTPUT COM
3	FG \perp	7	DC OUTPUT +V1
4	DC OUTPUT V3		

Block Diagram

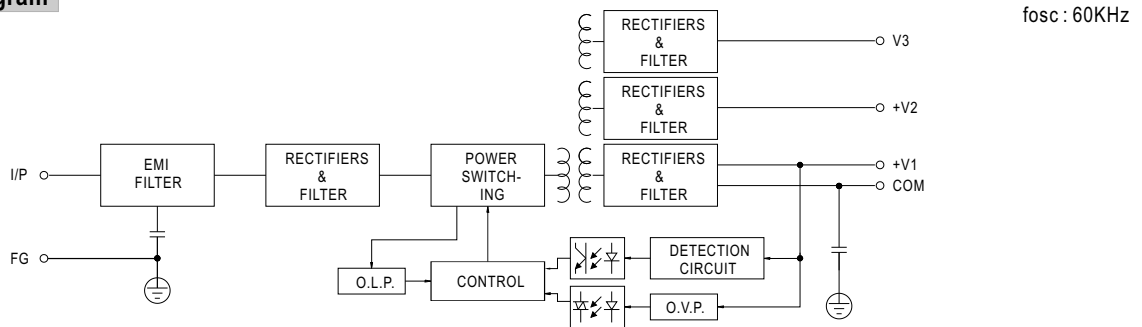

Derating Curve

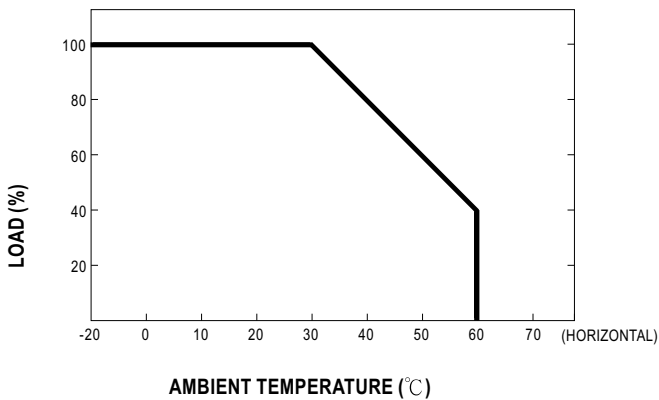

Output Derating VS Input Voltage

