

NEW

Radiometrix

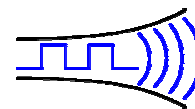

Hartcran House, 231 Kenton Lane, Harrow, HA3 8RP, England

Issue: 1, 20 December 2007

Tel: +44 (0) 20 8909 9595, Fax: +44 (0) 20 8909 2233

CTA88

8 bit Address - 8 bit Data encoder/decoder

CTA88 is an 8 bit address, 8 bit data encoder and decoder combined in a single IC. This device is intended to be used with ISM band telemetry modules and can be operated in either Encode or Decode mode.

CTA88 uses 1kbps differential Manchester bit balancing with preamble and checksum. It permits a simple, one way link to be established, for simple remote control applications, with a minimum of effort and no customer software input. CTA88 is available in 28pin SO and DIL packages.



Figure 1: CTA88 in 28 pin DIL package

Features

- Operating voltage (temperature):
 - 4.0V-5.5V for standard version (-40°C to +125°C)
 - 2.0V-5.5V for low voltage version (-40°C to +85°C)
- Draws <2mA without external load
- 8 bit address and 8 bit data
- 256 different remotes with 8 controls each
- Single packetised transmission for fast activation
- Maximum usage of the range capability of an RF module
- Adequate preamble to settle data slicer in the receiver.
- Extra wake up preamble to allow for transmitter power up time requirements
- Differential Manchester encoding of address, data and checksum
- Synchronisation codes and checksum to reduce false triggering on noise
- Suitable to be used with Narrow Band FM radio modules
- Ceramic resonator or crystal oscillator up to 20MHz
- Data rate up to 5.6kbps
- Minimum external component requirement
- Serial operation allow a PC to send or receive CTA88 command bursts
- Decoder timeout
- Up to 8 encoder/decoder modes including push button, delayed and continuous TX modes.

Applications

- Security and Alarm systems
- Emergency assistance call system
- Status reporting and monitoring systems
- RF Remote control systems
- Industrial controls
- HVAC controls
- Simple On/Off switching
- Long range telecontrol with Narrow Band FM radios

Encoder Mode

CTA88 can be put into Encoder Mode by connecting TX/RX MODE (pin 4) to supply (Vcc)

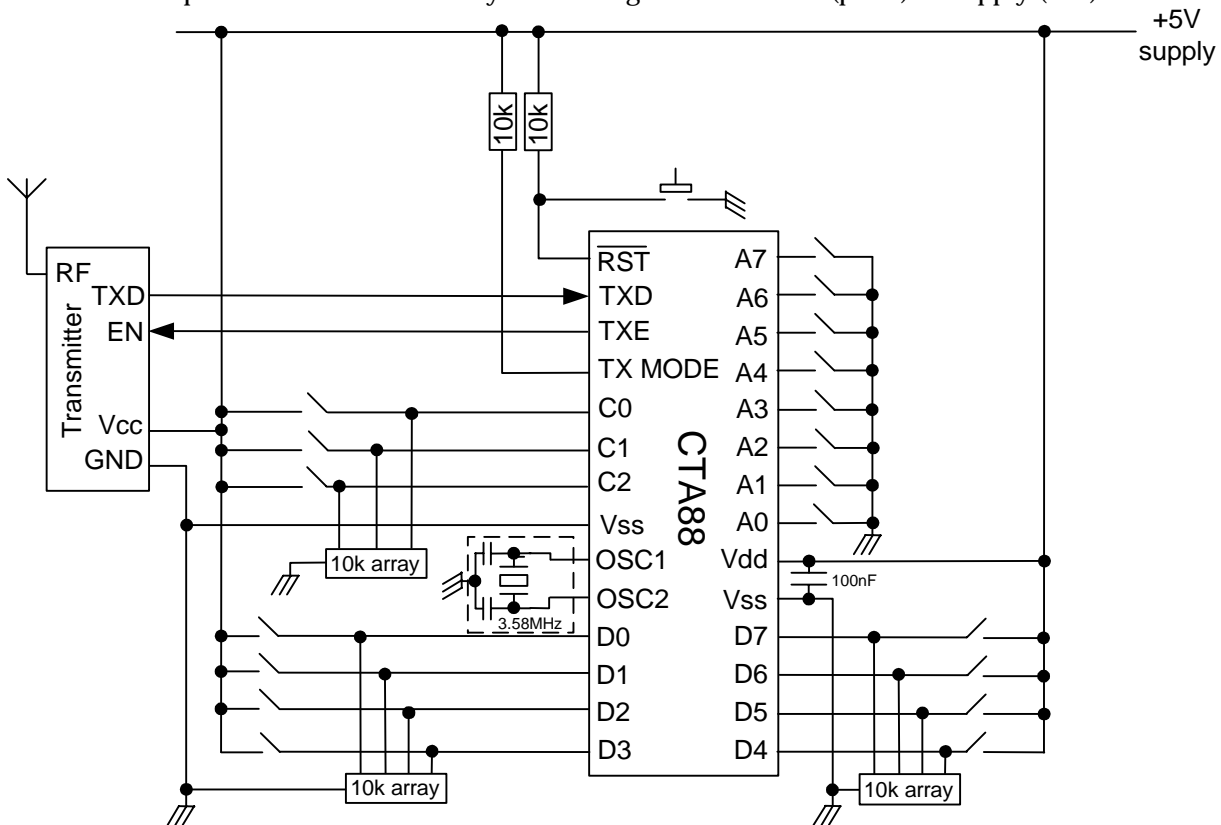

Figure 2: CTA88 in Encoder Mode

Pin	Name	Input/Output	Description
1	RST	Input	Active Low Reset (Connect to user system reset or tie to Vdd)
2	TXD	Output	Encoded Address and Data to TXD input of RF Transmitter
3	TXE	Output	high (Vdd) = enable radio transmitter module; low (0V) = TX OFF.
4	TX/RX MODE	Input	tie to Vcc = TX mode
5	C0	Input	Operating mode inputs ⁵
6	C1	Input	
7	C2	Input	
8	Vss	Supply	Supply Ground
9	OSC1	Output	Connect to 3.58MHz resonator ¹
10	OSC2	Input	Connect to 3.58MHz resonator ¹
11 - 18	D0 - D7	Input	8 bits of Data input (no internal pull-ups) ⁴
19	Vss	Supply	Supply Ground
20	Vdd	Supply	4.0V-5.5V supply (decouple with 100nF close to IC). 2.0V-5.5V (low voltage version)
21 - 28	A0 - A7	Input	8 bits of Address (Internal pull-ups to Vdd) ⁴

Notes:

- OSC1, 2 require a 3.58MHz ceramic resonator like KBR-3.58MKS (internal caps, ground middle pin).
If a 2 pin resonator or crystal is used, then two 15pF caps are needed : one from OSC1 to 0V ; one from OSC2 to 0V
- 'TXE' is active high. For units with $\overline{\text{TXE}}$ inputs, an inverting buffer will be needed
- Data and Address pins are logic true (1=VCC, 0=0V) inputs and outputs
- Data inputs have no pullups. Address inputs have weak pullups to Vcc and are schmitt trigger inputs
- C0-C2 (pins 5-7) are active high and have no pullups.
- A 1kbps bi-phase communications protocol is used, compatible with all Radiometrix Wireless modules
- A databurst is approximately 110mS long
- After asserting TX on high (active), the coder allows 50mS for TX to power up and settle
- Pin 4 (TX/RX MODE) has no pullup.
- Without external loads the chip draws less than 2mA from 5v

Decoder Mode

CTA88 can be put into Decoder Mode by connecting TX/RX MODE (pin 4) to ground (0V)

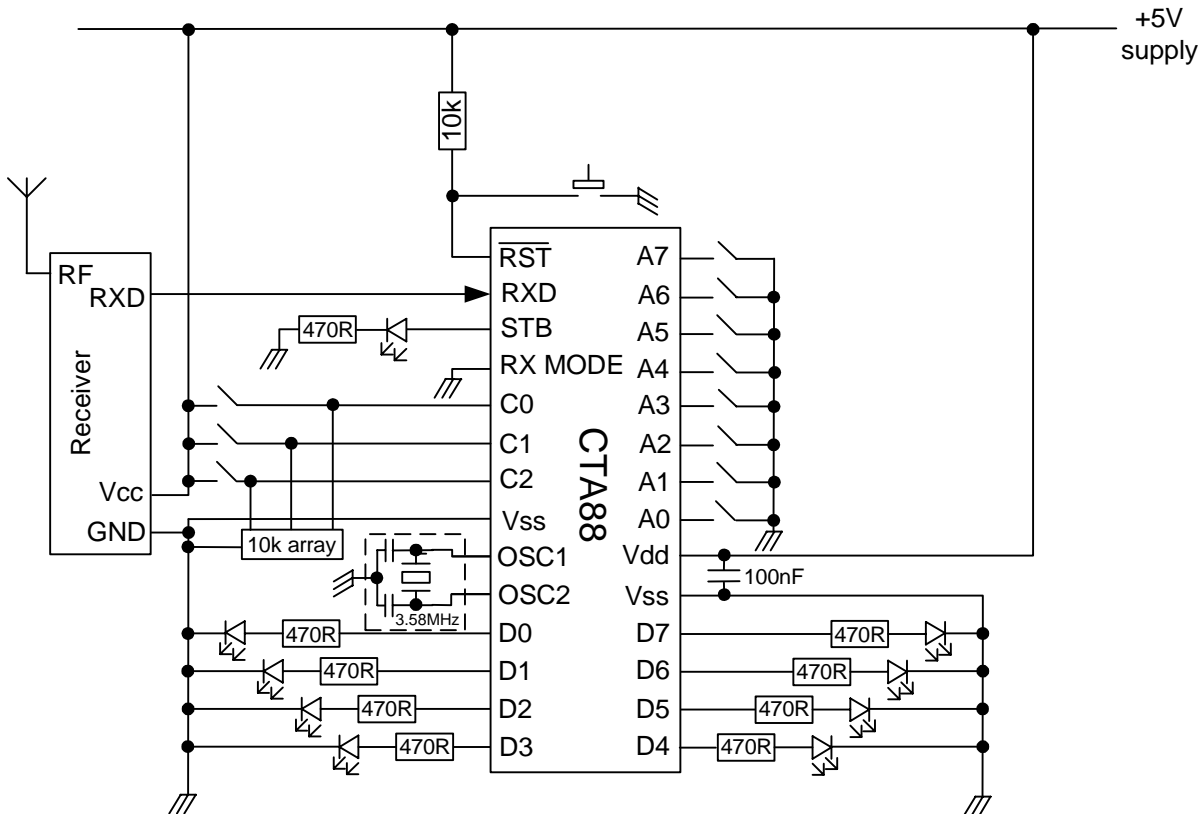

Figure 3: CTA88 in Decoder Mode

Pin	Name	Input/Output	Description
1	RST	Input	Active Low Reset (Connect to user system reset or tie to Vdd)
2	RXD	Output	baseband DATA from receiver module's RXD output
3	STB	Output	Valid data burst detect pulse (36mS long).
4	TX/RX MODE	Input	tie to Vss = RX mode
5	C0	Input	Operating mode inputs ⁴
6	C1	Input	
7	C2	Input	
8	Vss	Supply	Supply Ground
9	OSC1	Output	Connect to 3.58MHz resonator ¹
10	OSC2	Input	Connect to 3.58MHz resonator ¹
11 - 18	D0 - D7	Output	8 bits of Data Outputs
19	Vss	Supply	Supply Ground
20	Vdd	Supply	4.0V-5.5V supply (decouple with 100nF close to IC). 2.0V-5.5V (low voltage version)
21 - 28	A0 - A7	Input	8 bits of Address (Internal pull-ups to Vdd) ³

Notes:

- OSC1, 2 require a 3.58MHz ceramic resonator like KBR-3.58MKS (internal caps, ground middle pin).
If a 2 pin resonator or crystal is used, then two 15pF caps are needed : one from OSC1 to 0V ; one from OSC2 to 0V
- Data and Address pins are logic true (1=VCC, 0=0V) inputs and outputs
- Address inputs have weak pullups to Vcc and are schmitt trigger inputs
- C0-C2 (pins 5-7) are active high and have no pullups.
- A 1kbps bi-phase communications protocol is used, compatible with all Radiometrix Wireless modules
- A databurst is approximately 110mS long
- After asserting TX on high (active), the coder allows 50mS for TX to power up and settle
- Pin 4 (TX/RX MODE) has no pullup.
- Without external loads the chip draws less than 2mA from 5v

Operating modes

Device operation is set up by a 3 bit word, on the C0-C2 inputs.

TX / Encoder modes	
000	Device is inactive
001	Send single burst, once only (on reset, and on each C0 low/high transition)
010	Send continuously
011	Send single burst on any change of Data input word
100	Send continuously while any Data input pin is high
101	Send a burst on average every 1.75 seconds. A P/N sequence generates a delay of 1 - 2.5s between bursts
110	Serial mode (see notes)
111	Transmitter test. Send a constant 250Hz squarewave (C0=H, C1=H, C2=H)

RX / Decoder modes	
000	Local test. Data output word equals Address input word
001	Output last data received (150mS timeout)
010	Output last data (3 second timeout: see notes)
011	Hold last data received
100	D0-3 'set' corresponding bit, D4 resets D0, D5 resets D1 .. and so on
101	A '1' on any bit toggles the state of the corresponding output pin
110	Serial (see notes)
111	Link test. Data word outputs most recently received burst address

Which modes to use?

The CTA88 have a variety of operating modes. These are better understood by relating them to different applications:

1. **Wire replacment:** Operate transmitter in mode 010 (continuous: allows the STB output to be used as a 'good link' indicator) and receiver in mode 001.

If receiver operates in latched (011) mode then 'chattering' of the output is reduced (at extreme range, or with interferers present), but the link is no longer fail safe
Latched mode is also compatible with send on change (011)

2. **Momentary push buttons:** Transmitter in mode 100 (send while any input is high), receiver in 001. Outputs remain high for as long as the button is held down. This is the mode one would choose to control (for instance) a pan/tilt head (D0= slew left, D1 = slew right, etc)

3. **Controlling four lights:** Use transmit mode 100 (send while high) or 011 (send on change), with the receiver in mode 100. This gives four outputs (D0-D3), each set by one transmitter input (D0-D3) and reset by another (D4-D7)

4. **Monitoring infrequent events** (such as door open/shut): Use transmitter in periodic transmit (101, to keep channel occupancy and power usage low), and receiver on 010 (3 second timeout), 011 (hold last burst) or 110 (serial data output, to a PC or data logging device).

In this mode the transmit duty cycle is less than 10% on average, and the variable delay between bursts permits same channel operation of several CTA88 links with minimum transmit collisions

5. **Send burst on trigger event:** Set transmitter to mode 000 (off) and use C0 line high as a 'strobe' line. A pulse between 100uS and 25mS will initiate a single transmission.

This gives an idea of the usable combinations, but with a little imagination others will be found

Incompatibilities: Certain operating modes are not compatible with some of the others:

RX 101 (toggle) doesn't work with TX 101 (periodic send) as the outputs switch on and off at the send rate

RX 100 (set and reset) doesn't work with TX 101 (as the response is sluggish) and doesn't need TX 010 (constant)

RX 101 (toggle) is also not best suited to extreme range operation, where the initiation can be a little sporadic.

(At extreme range, latched (011) or set/reset (100) are the best receiver modes, combined with TX 100 (send on any '1') as in this mode the failure of any single burst to be received matters less, as the operator can continue to operate the transmitter until the receiver actuates)

Serial operation: The CTA88 is capable of a very simple, single byte, serial link operation. It is selected by a '110' mode input.

This function is mainly intended for diagnostic work in the lab, but it does allow a pc to send or receive CTA88 command bursts. Address is still selected by the parallel inputs

On the RX: D4 = 'true' RS232 output (+ve = low (0), 0V = idle/mark state)
D5 = 'inverted' RS232 output (+ve = idle/'mark' (1) state)
D6 : high for 500uS before, and during, serial byte output

On the TX D4 = RS232 input
D5 : low = set 'true' input polarity, high = set 'inverted' input polarity

In all cases a single 9600 baud byte is received or sent.

The link is not transparent: on the TX end the 'tx on' pin can be used as a 'busy' output

Timeout: In modes 001 and 010, the receiver outputs the last received data for a given period, before resetting D0-D7.

Any subsequent transmission will over-ride the current output state and reset the timer, even if the timeout period has not expired.

The short period is set to be slightly longer than the time between consecutive transmit bursts in a continuous mode.

The long timeout is usable with the randomised periodic transmission mode (101), as the 3 second timeout is longer than the longest delay between transmissions in this mode.

Versions of the chip can be supplied with this period extended to suit customer requirements

Ordering Information:

CTA88-000-SS	Standard (≤ 4 MHz)- No Frequency - Shrink Small Outline (SSOP)
CTA88-000-SO	Standard (≤ 4 MHz)- No Frequency - Small Outline (SO)
CTA88-000-DIL	Standard (≤ 4 MHz)- No Frequency - Plastic Dual In Package (PDIP)

CTA88L-000-SS	Low Voltage (≤ 4 MHz) - No Frequency - SSOP
CTA88L-000-SO	Low Voltage (≤ 4 MHz) - No Frequency - SO
CTA88L-000-DIL	Low Voltage (≤ 4 MHz) - No Frequency - PDIP

CTA88H-000-SS	High Speed (4MHz-20MHz) - No Frequency - SSOP
CTA88H-000-SO	High Speed (4MHz-20MHz) - No Frequency - SO
CTA88H-000-DIL	High Speed (4MHz-20MHz) - No Frequency - PDIP

Radiometrix Ltd

**Hartcran House
231 Kenton Lane
Harrow, Middlesex
HA3 8RP
ENGLAND**

**Tel: +44 (0) 20 8909 9595
Fax: +44 (0) 20 8909 2233
sales@radiometrix.com
www.radiometrix.com**

Copyright notice

This product data sheet is the original work and copyrighted property of Radiometrix Ltd. Reproduction in whole or in part must give clear acknowledgement to the copyright owner.

Limitation of liability

The information furnished by Radiometrix Ltd is believed to be accurate and reliable. Radiometrix Ltd reserves the right to make changes or improvements in the design, specification or manufacture of its subassembly products without notice. Radiometrix Ltd does not assume any liability arising from the application or use of any product or circuit described herein, nor for any infringements of patents or other rights of third parties which may result from the use of its products. This data sheet neither states nor implies warranty of any kind, including fitness for any particular application. These radio devices may be subject to radio interference and may not function as intended if interference is present. We do NOT recommend their use for life critical applications.

The Intrastat commodity code for all our modules is: 8542 6000

R&TTE Directive

After 7 April 2001 the manufacturer can only place finished product on the market under the provisions of the R&TTE Directive. Equipment within the scope of the R&TTE Directive may demonstrate compliance to the essential requirements specified in Article 3 of the Directive, as appropriate to the particular equipment.

*Further details are available on The Office of Communications (Ofcom) web site:
<http://www.ofcom.org.uk/radiocomms/ifi/>*

*Information Requests
Ofcom
Riverside House
2a Southwark Bridge Road
London SE1 9HA
Tel: +44 (0)20 7981 3000
Fax: +44 (0)20 7981 3333
information.requests@ofcom.org.uk*

*European Radiocommunications Office (ERO)
Peblingehus
Nansensgade 19
DK 1366 Copenhagen
Tel. +45 33896300
Fax +45 33896330
ero@ero.dk
www.ero.dk*