

# Low Noise, Step-Up PWM DC/DC Converter

## FEATURES

- 90% High Efficiency
- 1.6A, 0.3Ω, 12V Internal Power MOSFET
- 640kHz/1.2MHz Pin-Selectable Operation Frequency
- 2.6V to 5.5V Input Range
- Low Shutdown Current: 0.1μA
- Programmable Soft-Start
- External Compensation Network
- Adjustable Output from  $V_{IN}$  to 11V
- Thin 8-Pin MSOP Package

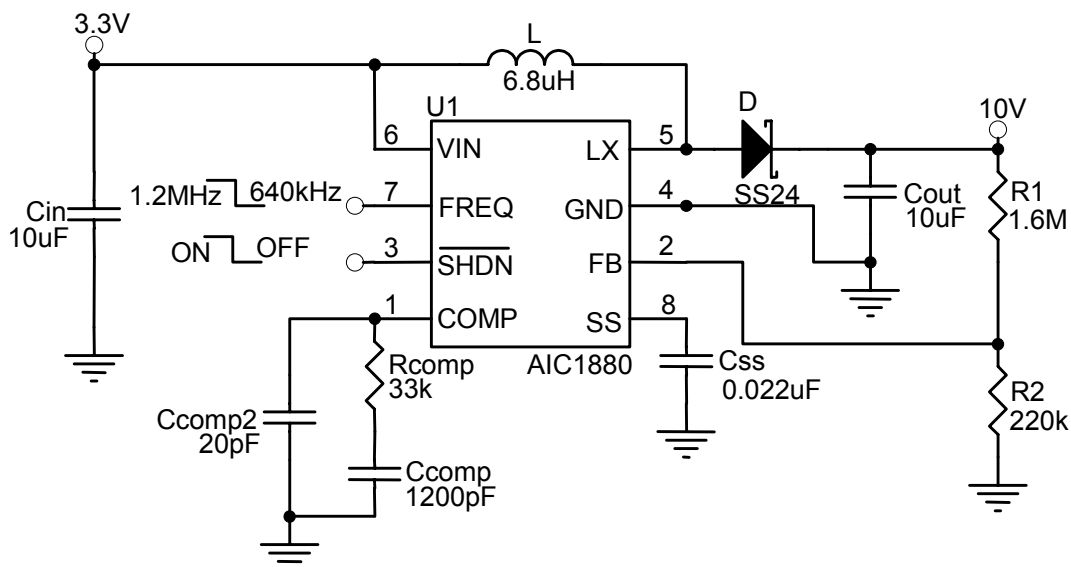
## APPLICATIONS

- TFT Bias Supplies
- Handheld Devices
- PCMCIA Cards
- Portable Equipment

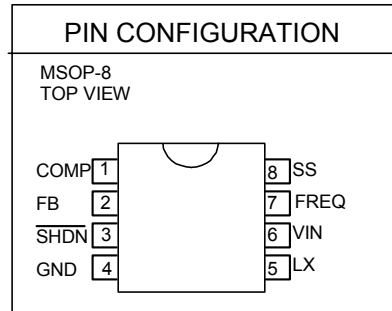
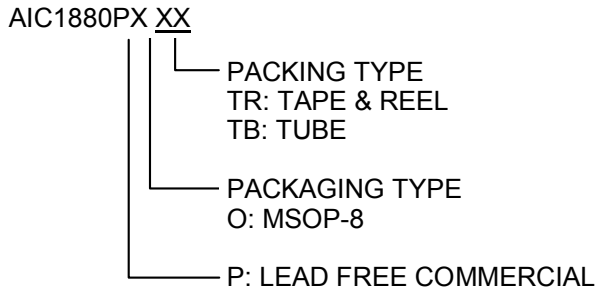
## DESCRIPTION

The AIC1880 is a step-up DC/DC converter with a 1.6A, 0.3Ω internal power switch. A soft-start programmed with an external capacitor sets the input current ramp rate. Pin-selectable high switching frequency (640kHz or 1.2MHz) allows easy filtering and low noises. An external compensation pin gives users flexibility in setting frequency compensation, which makes it feasible to use the small, low ESR ceramic output capacitors. The AIC1880 converts input ranging 2.6V to 5.5V into output voltage up to 11V. The device is available in a low profile 8-lead MSOP package.

## TYPICAL APPLICATION CIRCUIT



## ORDERING INFORMATION



Example: AIC1880POTR  
 → In MSOP-8 Package & Taping & Reel Packing Type

## ABSOLUTE MAXIMUM RATINGS

VIN, FB, $\overline{\text{SHDN}}$ , COMP, FREQ, SS to GND .....	-0.3 V to 5.5V
LX to GND .....	-0.3 V to 12V
Operating Ambient Temperature Range $T_A$ .....	-20°C to 85°C
Operating Maximum Junction Temperature $T_J$ .....	125°C
Storage Temperature Range .....	-65°C to 150°C
Lead Temperature (Soldering 10 Sec.) .....	260°C
Thermal Resistance Junction to Case MSOP-8 .....	75°C/W
Thermal Resistance Junction to Ambient MSOP-8 .....	180°C/W

(Assume no Ambient Airflow, no Heatsink)

**Absolute Maximum Ratings are those values beyond which the life of a device may be impaired.**

**ELECTRICAL CHARACTERISTICS**

( $T_A=25^\circ\text{C}$ ,  $V_{IN}=\overline{\text{SHDN}}=3\text{V}$ ,  $\text{FREQ}=\text{GND}$ , unless otherwise specified) (Note 1)

PARAMETER	TEST CONDITION	SYMBOL	MIN	TYP	MAX	UNIT
Input Voltage Range		$V_{IN}$	2.6		5.5	V
Under Voltage Lock Out		UVLO	2.20	2.35	2.50	V
Quiescent Current	$V_{FB}=1.3\text{V}$ , not switching	$I_{IN}$		0.18	0.35	mA
	$V_{FB}=1\text{V}$ , switching	$I_{IN}$		2	5	mA
Shutdown Current	$\overline{\text{SHDN}}=\text{GND}$	$I_{IN}$		0.1	1	$\mu\text{A}$
<b>SOFT-START</b>						
Soft-start current		$I_{SS}$	1.5	4	7	$\mu\text{A}$
<b>SWITCHING REGULATOR OSCILLATOR</b>						
Frequency	FREQ=GND	$F_{OSC}$	540	640	740	kHz
	FREQ= $V_{IN}$	$F_{OSC}$	1000	1220	1500	kHz
Maximum Duty Cycle	FREQ=GND	DC		85		%
	FREQ= $V_{IN}$	DC		85		%
Minimum Duty Cycle	FREQ=GND	DC		16		%
	FREQ= $V_{IN}$	DC		30		%
<b>ERROR AMPLIFIER</b>						
Feedback Voltage	Level to produce $V_{COMP}=1.24\text{V}$	$V_{FB}$	1.222	1.24	1.258	V
FB Input Bias Current	$V_{FB}=1.24\text{V}$	$I_{FB}$		0	40	nA
FB Voltage Line Regulation	Level to produce $V_{COMP}=1.24\text{V}$ $2.6\text{V} < V_{IN} < 5.5\text{V}$			0.05	0.3	%/V
Transconductance	$\Delta I=5\mu\text{A}$	GM		210		$\mu\text{mhos}$
<b>N-CHANNEL SWITCH</b>						
Current Limit		$I_{LIM}$		1.6		A
Internal Switch On-Resistance	$I_{LX}=1.2\text{A}$	$R_{ON}$		0.3	0.5	$\Omega$
Leakage Current	$V_{LX}=12\text{V}$	$I_{LXOFF}$		0.01	20	$\mu\text{A}$
<b>CONTROL INPUTS</b>						
Input Low Voltage	$\overline{\text{SHDN}}$ , FREQ $V_{IN}=2.6\text{V}$ to $5.5\text{V}$	$V_{IL}$			$0.3V_{IN}$	V
Input High Voltage	$\overline{\text{SHDN}}$ , FREQ $V_{IN}=2.6\text{V}$ to $5.5\text{V}$	$V_{IH}$		$0.7V_{IN}$		V
Hysteresis	$\overline{\text{SHDN}}$ , FREQ			$0.1 V_{IN}$		V
FREQ Pull-Down Current		$I_{FREQ}$	1.8	5	9	$\mu\text{A}$
$\overline{\text{SHDN}}$ Input Current		$I_{\overline{\text{SHDN}}}$		0.1	1	$\mu\text{A}$

Note 1: Specifications are production tested at  $T_A=25^\circ\text{C}$ . Specifications over the  $-20^\circ\text{C}$  to  $85^\circ\text{C}$  operating temperature range are assured by design, characterization and correlation with Statistical Quality Controls (SQC).

## TYPICAL PERFORMANCE CHARACTERISTICS

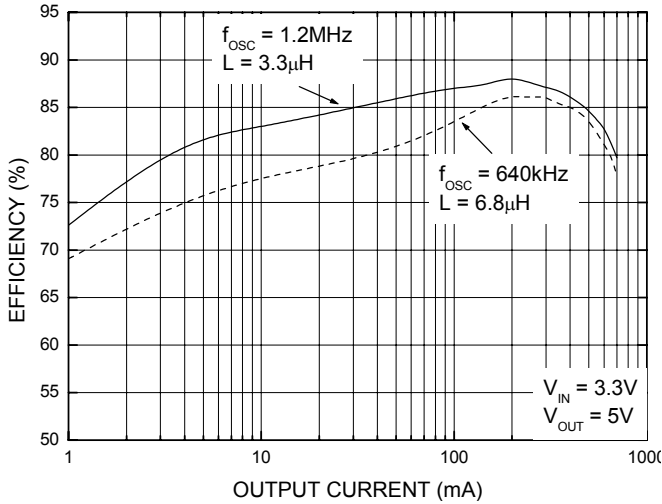


Fig. 1 Efficiency at  $V_{IN}=3.3\text{V}$ ,  $V_{OUT}=5\text{V}$

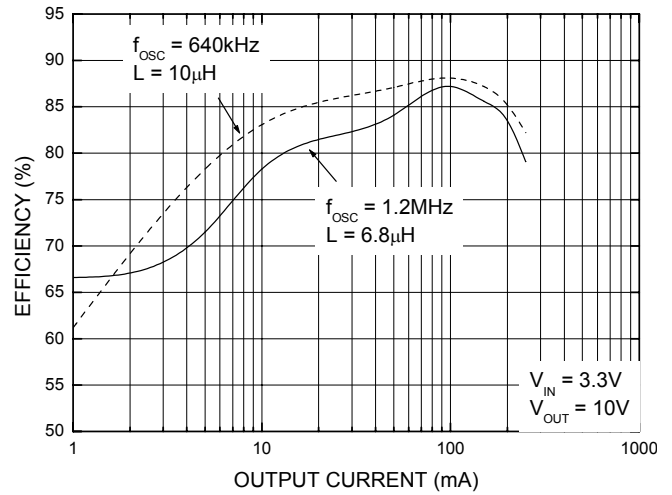


Fig. 2 Efficiency at  $V_{IN}=3.3\text{V}$ ,  $V_{OUT}=10\text{V}$

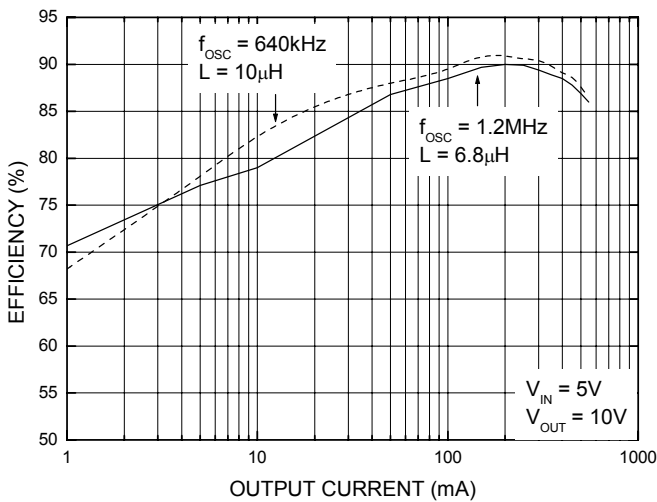


Fig. 3 Efficiency at  $V_{IN}=5\text{V}$ ,  $V_{OUT}=10\text{V}$

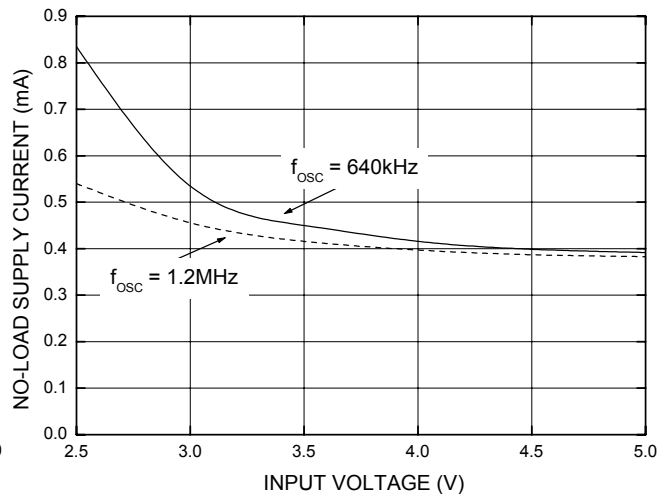


Fig. 4 No-Load supply current

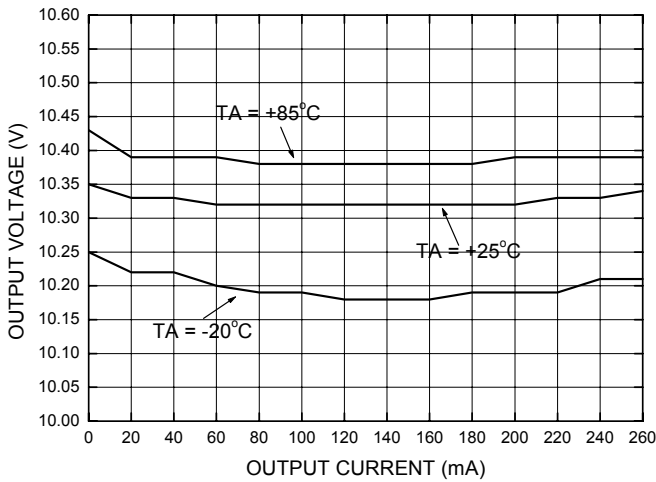
**TYPICAL PERFORMANCE CHARACTERISTICS (Continued)**


Fig. 5 Load regulation

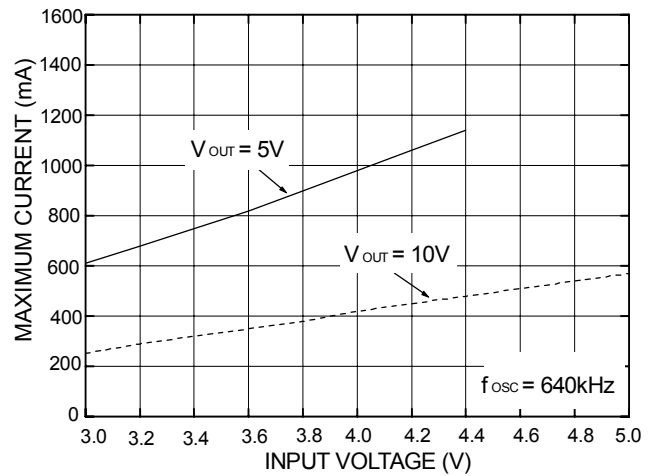


Fig. 6 Maximum output current vs. Input voltage

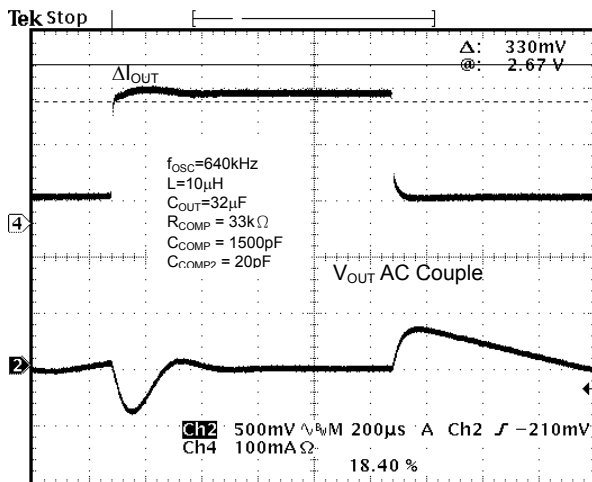
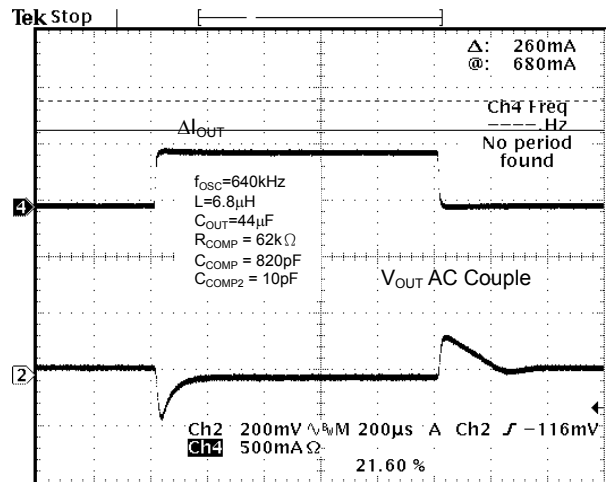
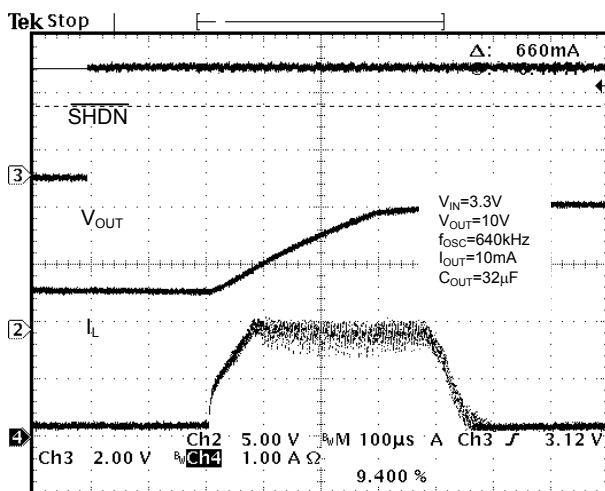

 Fig. 7 Load-transient response at  $V_{IN}=3.3\text{V}$ ,  $V_{OUT}=10\text{V}$ 

 Fig. 8 Load-transient response at  $V_{IN}=3.3\text{V}$ ,  $V_{OUT}=5\text{V}$ 


Fig. 9 Startup waveform without soft-start

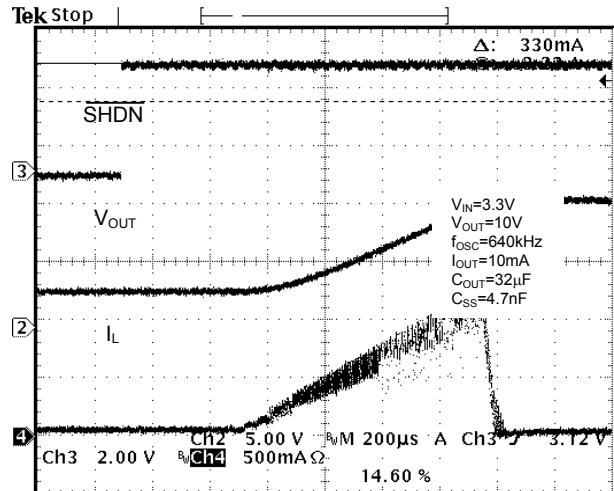
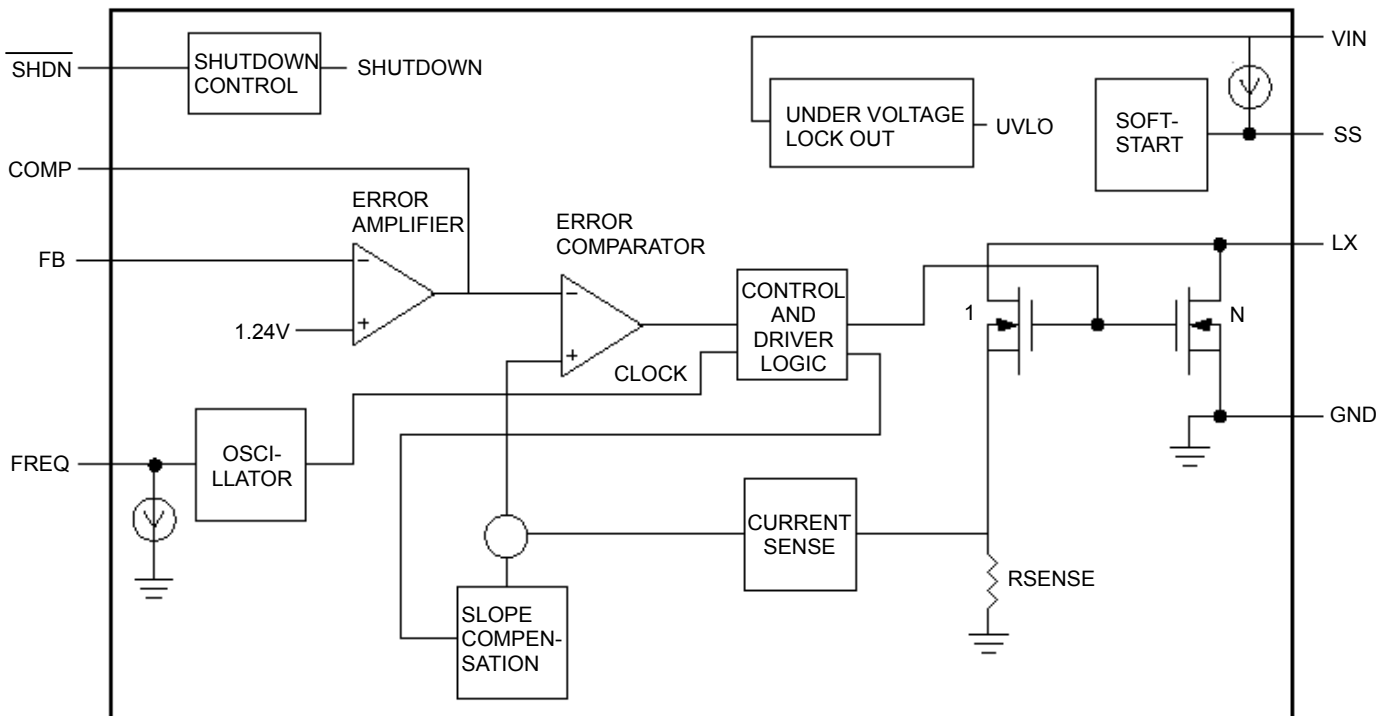


Fig. 10 Startup waveform with soft-start

## ■ BLOCK DIAGRAM



## ■ PIN DESCRIPTIONS

- PIN 1: COMP - Compensation Pin for Error Amplifier.
- PIN 2: FB - Feedback Pin with a typical reference voltage of 1.24V.
- PIN 3:  $\overline{\text{SHDN}}$  - Shutdown Control Pin. The Device will turn off when SHDN is Low.
- PIN 4: GND - Ground.
- PIN 5: LX - Switch Pin.
- PIN 6: VIN - Power Supply Pin.

- PIN 7: FREQ - Frequency Select Pin. Oscillator frequency is 640kHz when FREQ connects to GND, and 1.2MHz when FREQ connects to VIN.
- PIN 8: SS - Soft-Start Control Pin. Connect a soft-start capacitor to this pin. A 4 $\mu$ A constant current charges the soft-start capacitor. Leave open for no soft-start.

## ■ COMPONENT SELECTION

$V_{IN}$ (V)	$V_{OUT}$ (V)	$f_{osc}$ (Hz)	L ( $\mu$ H)	$C_{OUT}$ ( $\mu$ F)	$R_{COMP}$ (k $\Omega$ )	$C_{COMP}$ (pF)	$C_{COMP2}$ (pF)	TYPICAL $I_{OUT(MAX)}$ (mA)
3.3	10	640k	10 (Taiyo Yuden NP06D B100M)	10 ceramic (Taiyo Yuden EMK325BJ106MN-B)	39	820	20	250
3.3	10	1.2M	6.8 (Taiyo Yuden NP06D B6R8M)	10 ceramic (Taiyo Yuden EMK325BJ106MN-B)	33	1200	20	250
3.3	5	640k	10 (Taiyo Yuden NP06D B100M)	10 $\times$ 2 ceramic (Taiyo Yuden EMK325BJ106MN-B)	30	820	10	700
3.3	5	1.2M	4.7 (Taiyo Yuden NP06D B4R7M)	10 $\times$ 2 ceramic (Taiyo Yuden EMK325BJ106MN-B)	36	1000	20	700
5.0	10	640k	10 (Taiyo Yuden NP06D B100M)	10 $\times$ 2 ceramic (Taiyo Yuden EMK325BJ106MN-B)	30	1200	20	500
5.0	10	1.2M	6.8 (Taiyo Yuden NP06D B6R8M)	10 $\times$ 2 ceramic (Taiyo Yuden EMK325BJ106MN-B)	22	1500	56	500

## ■ APPLICATION INFORMATION

### Operation

The AIC1880 is a fixed-frequency and high efficiency step-up DC/DC converter with current-mode PWM control architecture. By selecting appropriate circuit components, it can achieve fast transient response. The AIC1880 can regulate its output voltage through a feedback control circuit, which is composed of an error amplifier; two comparators and several control signal generators. By comparing the voltage at FB pin to the reference voltage of 1.24, the error amplifier varies the voltage at COMP pin. The voltage at COMP pin is compared with the summing signal of current sensing signal and slope compensation signal to determine the duty cycle of internal power switch. In order to prevent overcharging the output capacitor and achieve better efficiency, AIC1880 will enter pulse-skipping mode (PSM) operation while working at light load conditions.

### Frequency Selection

The AIC1880's switching frequency can be selected to be either 640kHz or 1.2MHz. The switching frequency is 640kHz, while FREQ pin is connected to GND. The

switching frequency is 1.2MHz, as FREQ pin is connected to  $V_{IN}$ . For 640kHz operation, an internal pull-low of FREQ pin allows the FREQ pin unconnected.

### Current Limitation

Current limitation function of AIC1880 will be activated when the peak value of switch current reaches 1.6A (typ.). While the current limitation function is activated, the duty cycle will be reduced to limit the output power to protect the internal power switch.

### Soft-Start

The AIC1880 provides the soft-start function. When  $\overline{SHDN}$  pin is connected to  $V_{IN}$ , an internal current source of 4 $\mu$ A (typ.) charges an external soft-start capacitor. During the soft-start period, the voltage at SS pin will decide the allowable peak value of switch current. The peak value of switch current is 0A, when the voltage at SS pin is 0V. In addition, it is in full current limitation when the voltage at SS pin is higher than 1.0V. The soft-start time can be calculated in accordance with the following equation.

$$t_{SS} = C_{SS} \times \frac{1.0V}{4\mu A}$$

The soft-start capacitor is discharged to GND when the  $\overline{\text{SHDN}}$  pin is connected to GND.

### Shutdown

By connecting the  $\overline{\text{SHDN}}$  pin to GND, the AIC1880 can be shut down to reduce the supply current to 0.1 $\mu$ A (typ.). At this operation mode, the output voltage of step-up converter is approximately equal to  $(V_{IN}-V_D)$ .  $V_D$  is the forward drop voltage of catch diode.

### Components Selection

#### Inductor

The inductor selection depends on the switching frequency and current ripple of inductor.

$$L \geq \frac{V_{IN}}{f_{OSC} \cdot \Delta I_L} \left( 1 - \frac{V_{IN}}{V_{OUT}} \right)$$

The AIC1880's switching frequency can be selected to be either 640kHz or 1.2MHz. A higher switching frequency allows the use of a smaller inductance. However, higher switching frequency can cause more switching losses, resulting in lower efficiency. By setting the switching frequency and an acceptable current ripple of inductor, a suitable inductance can be obtained from above equation.

In addition, it is important to ensure the inductor saturation current exceeds the peak value of inductor current in application to prevent core saturation. The peak value of inductor current can be calculated according to the following equation.

$$\begin{aligned} I_{PEAK} &= I_{IN(max)} + \frac{V_{IN}}{2 \times f_{OSC} \cdot L} \left( 1 - \frac{V_{IN}}{V_{OUT}} \right) \\ &= \frac{I_{OUT(MAX)} \cdot V_{OUT}}{\eta \cdot V_{IN}} + \frac{V_{IN}}{2 \times f_{OSC} \cdot L} \left( 1 - \frac{V_{IN}}{V_{OUT}} \right) \end{aligned}$$

#### Diode

A Schottky diode with low forward drop voltage and fast reverse recovery is the ideal choice for better effi-

ciency. The forward drop voltage of a Schottky diode will result in the conduction losses in the diode, and the diode capacitance ( $C_T$  or  $C_D$ ) will cause the switching losses. Therefore, it is necessary to consider both forward voltage drop and diode capacitance for diode selection. In addition, the rating of selected Schottky diode should be able to handle the output voltage and the maximum peak diode current.

#### Input Capacitor

To prevent the large input voltage ripple resulted from high frequency switching, the use of low ESR ceramic capacitor is recommended. A 10 $\mu$ F ceramic capacitor is sufficient for most AIC1880 applications.

#### Output Capacitor

The selection of output capacitor depends on the required output voltage ripple. The output voltage ripple can be expressed as:

$$\Delta V_{OUT} = \frac{I_{OUT}}{f_{OSC} \cdot C_{OUT}} \left( 1 - \frac{V_{IN}}{V_{OUT}} \right) + ESR \cdot \Delta I_L$$

For lower output voltage ripple, the use of low ESR ceramic capacitor is recommended. The tantalum capacitor can also be used well, but its ERS is larger than that of ceramic capacitor.

#### Soft-Start Capacitor

The soft-start of AIC1880 begins from  $V_{SS}=0V$  and ends while  $V_{SS}$  reaches 1.0V. During the soft-start period, an internal current source of 4 $\mu$ A (typ.) charges the soft-start capacitor. Hence, the soft-start capacitor should be large enough to ensure that the output voltage has reached the regulation value before the soft-start function has finished.

#### Output Voltage Programming

By connecting a resistive divider  $R_1$  and  $R_2$ , the output voltage of AIC1880 step-up converter can be set.  $V_{OUT}$  can be calculated as:



$$V_{OUT} = 1.24 \times \left( 1 + \frac{R_1}{R_2} \right)$$

The resistive divider should sit as close to FB pin as possible.

### Loop Compensation

In order to avoid the poor output voltage ripple and low efficiency caused by instability, AIC1880 requires a proper external compensation network to compensate its feedback loop. In this external compensation network,  $R_{COMP}$  is used to set the high-frequency integrator gain for fast transient response. While  $R_{COMP}$  is decided,  $C_{COMP}$  is chosen to set the integrator zero to maintain the loop stability.  $C_{COMP2}$  is used to cancel the zero caused by the output capacitor and its ESR. While using the ceramic capacitor as the output capacitor,  $C_{COMP2}$  can be omitted due to the small ESR.

$$R_{COMP} \cong 10 \times \sqrt{\frac{C_{OUT}}{L}} \times \frac{V_{OUT}}{V_{IN}} \text{ (k}\Omega\text{)}$$

$$C_{COMP} \cong \frac{R_L \cdot C_{OUT}}{10 \times R_{COMP}} \text{ (F)}$$

$$C_{COMP2} \cong \frac{ESR \times C_{OUT}}{R_{COMP}} \text{ (F)}$$

For each components of external compensation network, the above equations provide the approximate calculations. In order to obtain better transient per-

formance, it is necessary to adjust the component values of external compensation network.

### Layout Consideration

In order to ensure a proper operation of AIC1880, the following points should be managed comprehensively.

1. The input capacitor and  $V_{IN}$  should be placed as close as possible to each other to reduce the input ripple voltage.
2. The output loop, which is consisted of the inductor, the internal power switch, the Schottky diode and the output capacitor, should be kept as small as possible.
3. The routes with large current should be kept short and wide.
4. Logically the large current on the converter should flow at the same direction.
5. The FB pin should be connected to the feedback resistors directly and the route should be away from the noise sources.
6. The soft-start capacitor should be connected to the SS pin and GND pin directly.

APPLICATION EXAMPLES

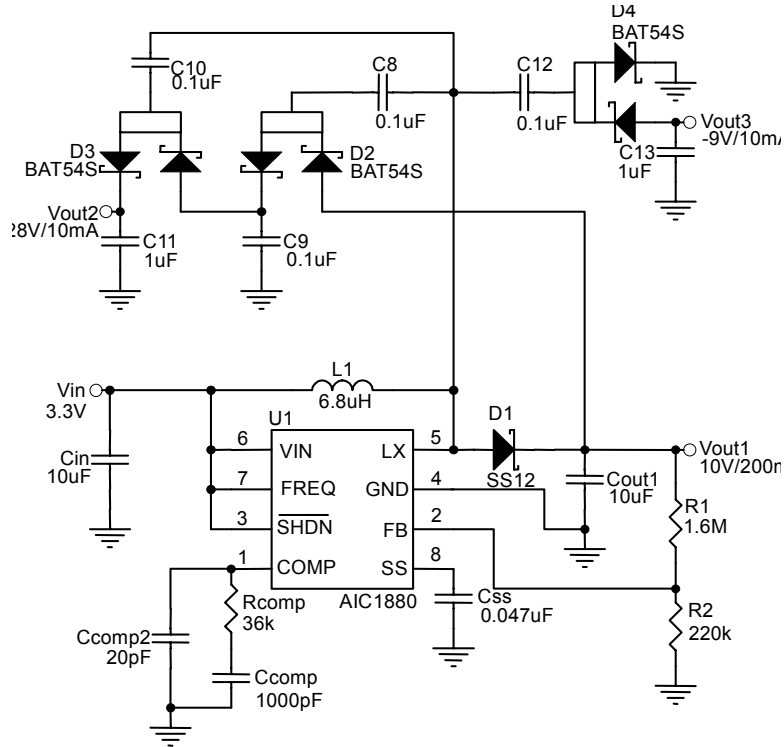


Fig. 11 TFT LCD Bias Supply at  $V_{IN}=3.3V$

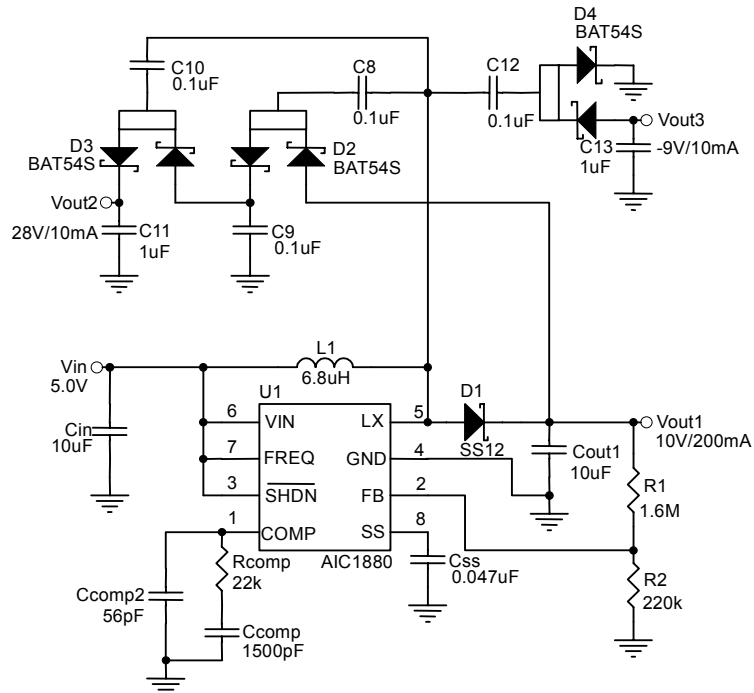
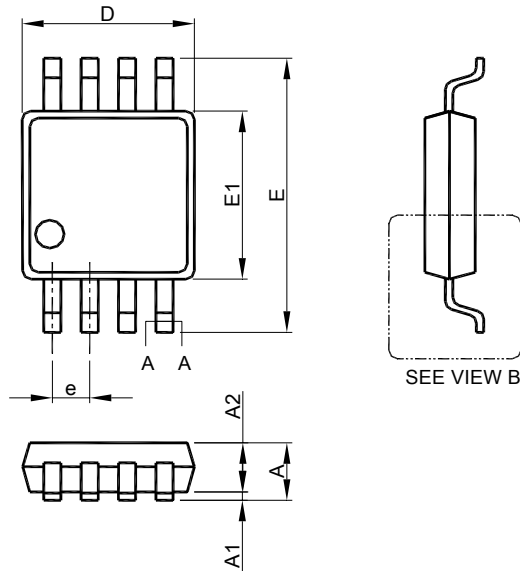


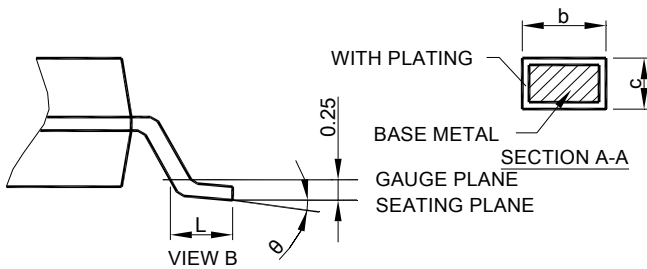
Fig. 12 TFT LCD Bias Supply at  $V_{IN}=5.0V$

**PHYSICAL DIMENSIONS** (unit: mm)

## ● MSOP-8



SEE VIEW B



SYMBOL	MSOP-8	
	MILLIMETERS	
	MIN.	MAX.
A		1.10
A1	0.05	0.15
A2	0.75	0.95
b	0.25	0.40
c	0.13	0.23
D	2.90	3.10
E	4.90 BSC	
E1	2.90	3.10
e	0.65 BSC	
L	0.40	0.70
q	0°	6°

- Note: 1. Refer to JEDEC MO-187AA.  
 2. Dimension "D" does not include mold flash, protrusions or gate burrs. Mold flash, protrusion or gate burrs shall not exceed 6 mil per side.  
 3. Dimension "E1" does not include inter-lead flash or protrusions.  
 4. Controlling dimension is millimeter, converted inch dimensions are not necessarily exact.

**Note:**

Information provided by AIC is believed to be accurate and reliable. However, we cannot assume responsibility for use of any circuitry other than circuitry entirely embodied in an AIC product, nor for any infringement of patents or other rights of third parties that may result from its use. We reserve the right to change the circuitry and specifications without notice.

Life Support Policy: AIC does not authorize any AIC product for use in life support devices and/or systems. Life support devices or systems are devices or systems which, (i) are intended for surgical implant into the body or (ii) support or sustain life, and whose failure to perform, when properly used in accordance with instructions for use provided in the labeling, can be reasonably expected to result in a significant injury to the user.