



**Features**

- DC to >6GHz Operation
- 2.7V to 4.0V Single Supply
- High Input IP<sub>3</sub>
- 1.5dB Noise Figure at 2400MHz
- 14dB Gain at 2400MHz
- Low Current Consumption of 6mA at 3V

**Applications**

- TDMA/CDMA PCS LNA
- TDMA/CDMA/FM Cellular LNA
- ISM Band LNA/Driver
- Low Noise Transmit Driver Amplifier
- General Purpose Amplification
- Commercial and Consumer Systems

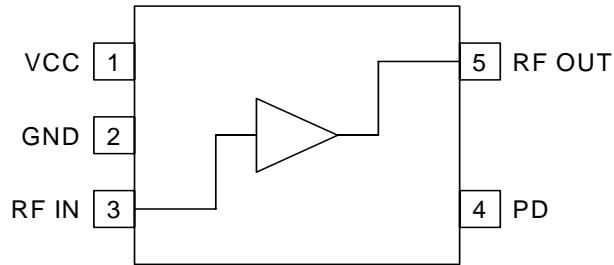

Functional Block Diagram

**Product Description**

The RF2472 is a general purpose, low-cost, high-performance low noise amplifier (LNA) designed for operation from a 2.7V to 4V supply with low current consumption. The device is optimized for 2.4GHz LNA applications, but is also useful for 1.9GHz PCS, K-PCS, 900MHz ISM band, 1.5GHz GPS, and 4.9GHz to 5.9GHz WLAN applications. The RF2472 is available in an industry-standard SOT23 5-lead surface mount package, enabling compact designs which conserve printed circuit board space.

**Ordering Information**

RF2472	2.4GHz Low Noise Amplifier with Enable (Sn-Pb finish)
RF2472G	2.4GHz Low Noise Amplifier with Enable (Matte-Sn (Pb-free) finish)
RF2472 PCBA-410	Fully Assembled Evaluation Board, 2.4GHz
RF2472 PCBA-411	Fully Assembled Evaluation Board, 1.9GHz

**Optimum Technology Matching® Applied**

- |                                      |   |                                     |                                   |
|--------------------------------------|---|-------------------------------------|-----------------------------------|
| <input type="checkbox"/> GaAs HBT    | <input checked="" type="checkbox"/> SiGe BiCMOS | <input type="checkbox"/> GaAs pHEMT | <input type="checkbox"/> GaN HEMT |
| <input type="checkbox"/> GaAs MESFET | <input type="checkbox"/> Si BiCMOS              | <input type="checkbox"/> Si CMOS    |                                   |
| <input type="checkbox"/> InGaP HBT   | <input type="checkbox"/> SiGe HBT               | <input type="checkbox"/> Si BJT     |                                   |

RF MICRO DEVICES®, RFMD®, Optimum Technology Matching®, Enabling Wireless Connectivity™, PowerStar®, POLARIS™ TOTAL RADIO™ and UltimateBlue™ are trademarks of RFMD, LLC. BLUETOOTH is a trademark owned by Bluetooth SIG, Inc., U.S.A. and licensed for use by RFMD. All other trade names, trademarks and registered trademarks are the property of their respective owners. ©2006, RF Micro Devices, Inc.

## Absolute Maximum Ratings

Parameter	Rating	Unit
Supply Voltage	-0.5 to 4.0	V
Input RF Level	0	dBm
Operating Ambient Temperature	-40 to +85	°C
Storage Temperature	-40 to +150	°C



**Caution!** ESD sensitive device.

Exceeding any one or a combination of the Absolute Maximum Rating conditions may cause permanent damage to the device. Extended application of Absolute Maximum Rating conditions to the device may reduce device reliability. Specified typical performance or functional operation of the device under Absolute Maximum Rating conditions is not implied.

RoHS status based on EU Directive 2002/95/EC (at time of this document revision).

The information in this publication is believed to be accurate and reliable. However, no responsibility is assumed by RF Micro Devices, Inc. ("RFMD") for its use, nor for any infringement of patents, or other rights of third parties, resulting from its use. No license is granted by implication or otherwise under any patent or patent rights of RFMD. RFMD reserves the right to change component circuitry, recommended application circuitry and specifications at any time without prior notice.

Parameter	Specification			Unit	Condition
	Min.	Typ.	Max.		
<b>Overall</b>					T=27 °C, V <sub>CC</sub> =3.0V
Frequency Range		DC to >6000		MHz	
<b>2.4GHz LNA Operation</b>					T=27 °C, V <sub>CC</sub> =3.0V, Freq=2440MHz
Gain	13.0	14.6	17.0	dB	
Noise Figure		1.5		dB	
Input IP3	+8.0	+10.0	+20.0	dBm	Two tones at 1MHz spacing, -15dBm output
Input P1dB		-10		dBm	
<b>PCS and K-PCS LNA Operation</b>					T=27 °C, V <sub>CC</sub> =3.0V, Freq=1960MHz
Gain		16.3		dB	
Noise Figure		1.4		dB	
Input IP3		+8		dBm	Two tones at 1MHz spacing, -12dBm output
Input P1dB		-12		dBm	
<b>4.9GHz to 5.9GHz LNA Operation</b>					T=27 °C, V <sub>CC</sub> =3.0V, Freq=4.9GHz to 5.9GHz
Gain	9.0	10.5	11.5	dB	
Noise Figure	1.7	1.9	2.0	dB	
<b>Power Supply</b>					
Operating Voltage		2.7 to 3.6		V	
Operating Current	4.0	6.0	8.0	mA	V <sub>CC</sub> =3.0V, PD=3.0V
		<1.0	3.0	µA	V <sub>CC</sub> =3.0V, PD=0V

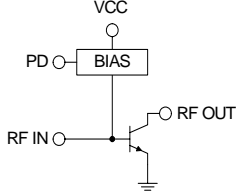
Pin	Function	Description	Interface Schematic
1	VCC	Supply connection. An external bypass capacitor may be required in some applications.	See pin 3.
2	GND	Ground connection. Keep traces physically short and connect immediately to ground plane for best performance.	
3	RF IN	RF input pin. This pin is DC coupled and matched to 50Ω at 2.4GHz.	
4	PD	Power down pin. This pin enables the bias to the amplifier. To turn the amplifier on, this pin should be connected to V <sub>CC</sub> . Connecting this pin to ground, will turn the amplifier off and reduce the current draw to below 1μA. This pin is a CMOS input. There is no DC current draw other than the transient current required to charge or discharge the gate capacitance (less than 5 pF).	
5	RF OUT	LNA Output pin. This pin is an open-collector output. It must be biased to V <sub>CC</sub> through a choke or matching inductor. This pin is typically matched to 50Ω with a shunt bias/matching inductor and series blocking/matching capacitor. Refer to application schematics.	See pin 3.

**Package Drawing**

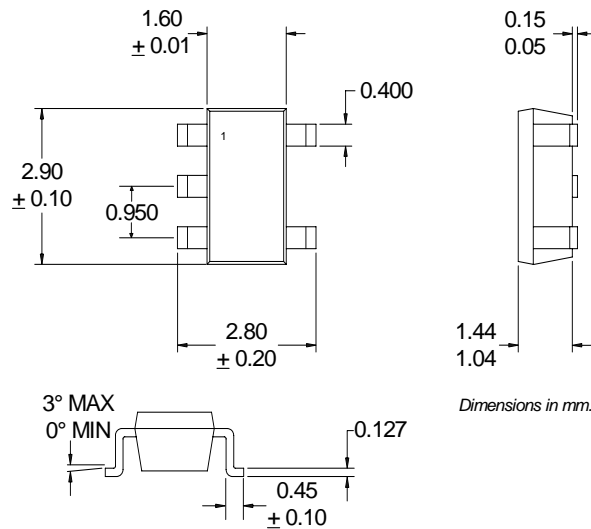

## Theory of Operation

The RF2472 is a low-noise amplifier with internal bias circuitry. It is DC-coupled on the input and output; therefore, it can be used to arbitrarily low frequency. It has useful gain to above 6GHz. Its design is optimized for use at 2.4GHz. Because of the high-frequency gain, the designer must take care to ensure that the device will remain stable outside the desired operating frequency. The RF2472 is capable of providing outstanding linearity, but to achieve this high performance, the circuit designer must pay attention to the terminations that are presented to low-frequency intermodulation products.

### Stability

The RF2472 must be stabilized for frequencies outside of the desired operating range. Ground connections should be kept as short as possible. Wherever practical, ground should be provided by a via hole directly to a continuous ground layer. Highly reflective terminations to the RF input and output pins should be avoided whenever possible. In most circumstances, a resistor in parallel with an inductor in the bias line on pin 5 will improve the stability of the circuit. See the application schematics for examples. The 10nH inductor in the bias line is part of an output impedance matching circuit. At higher frequencies, the impedance of the matching circuit, alone, would become highly inductive. The large reactive termination of the output port could cause the circuit to oscillate at a high frequency. The resistance in parallel with the inductor adds a real part to the high-frequency termination that will have a stabilizing effect on the circuit.

### Linearity

The 22nF bypass and coupling capacitors in the application schematics may seem excessively large for circuits intended to operate at 1.9GHz and 2.4GHz. These large capacitors provide a low impedance path to ground for second-order mixing products that leads to improved third-order intermodulation performance. The effect is most easily seen for the input coupling capacitor. A 100pF capacitor would provide low enough impedance to couple a 2.4GHz signal into the input pin of the RF2472. However, low-frequency intermodulation products caused by second-order nonlinearities would be presented with a large reactive impedance at the input pin. Relatively large voltages for these low-frequency products would be allowed to mix with the fundamental signals at the input pin, resulting in relatively large, in-band, third-order products.

With a large coupling capacitor, the low-frequency products would be presented with a low impedance, via the input source impedance, resulting in a lower voltage at the input pin. These products, in turn, would mix at a lower level with the fundamental signals to produce lower in-band, third-order products.

Some designers may be concerned about the self-resonant frequency of large coupling capacitors. A 22nF capacitor will probably pass through self resonance below 100MHz. Beyond resonance, the reactance of the capacitor will turn inductive, but the internal losses of the capacitor will usually prevent the component from exhibiting a large reactive impedance.

### Third-Order Intercept versus 1-dB Compression Point

For many devices, the third-order intercept point is approximately 10dB higher than the 1-dB compression point. This rule of thumb does not apply for the RF2472. It is normal to find that the third-order intercept point is 20 dB higher than the 1-dB compression point. This behavior is common for SiGe devices. The reason for the difference is that the 10dB rule is based on a simple third-order polynomial model for device nonlinearities. For SiGe devices this simple model is not a good fit.

**Application Schematic - 1.9 GHz**

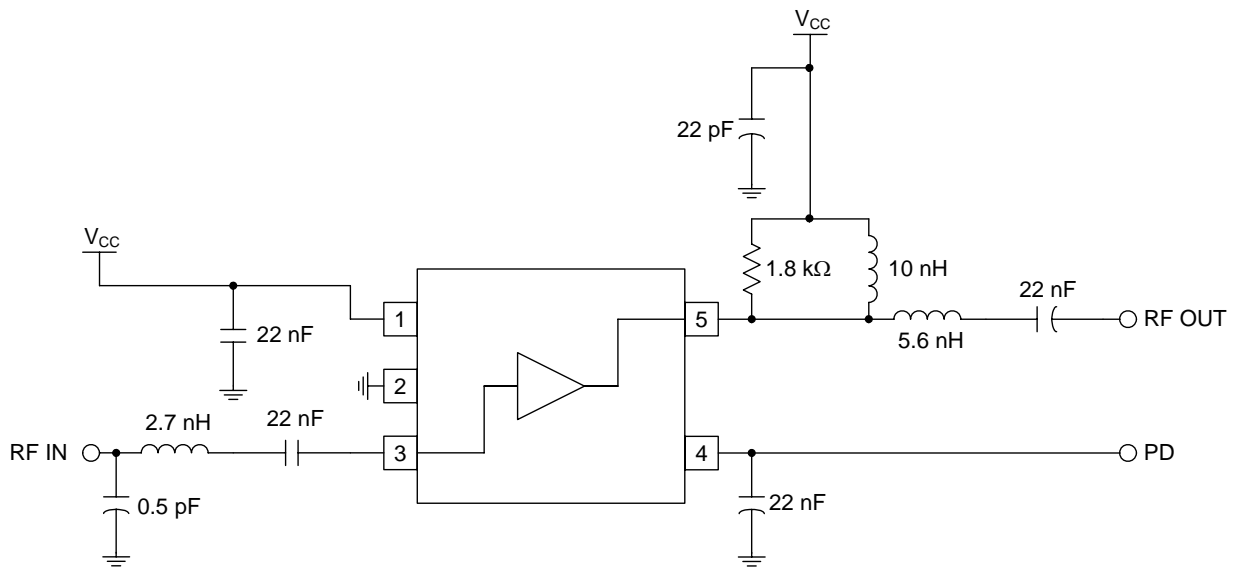

**Application Schematic - 2.4 GHz**

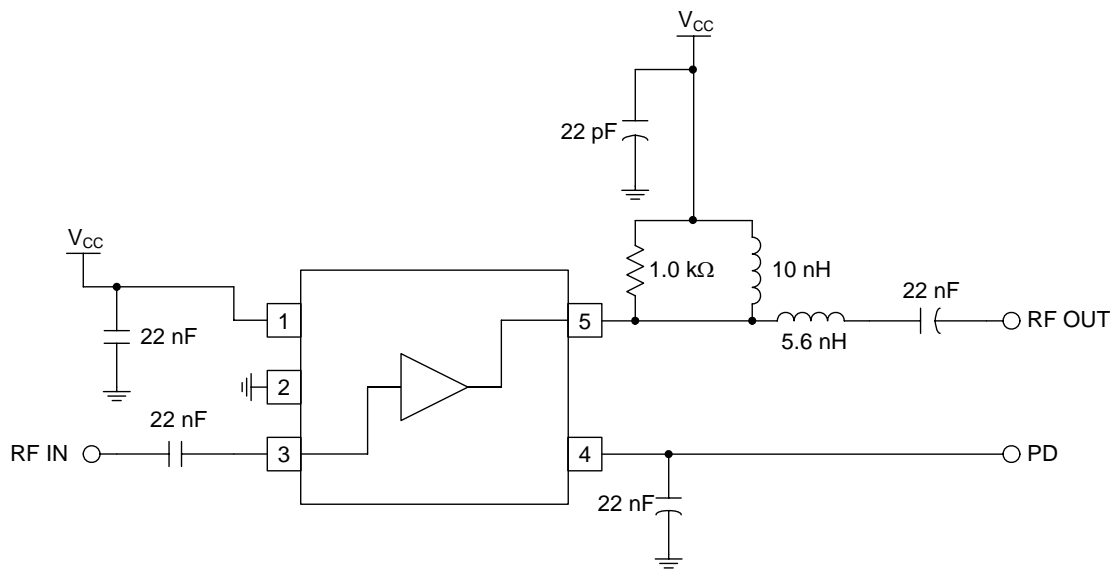

## Application Schematic - 4.9GHz to 5.9GHz

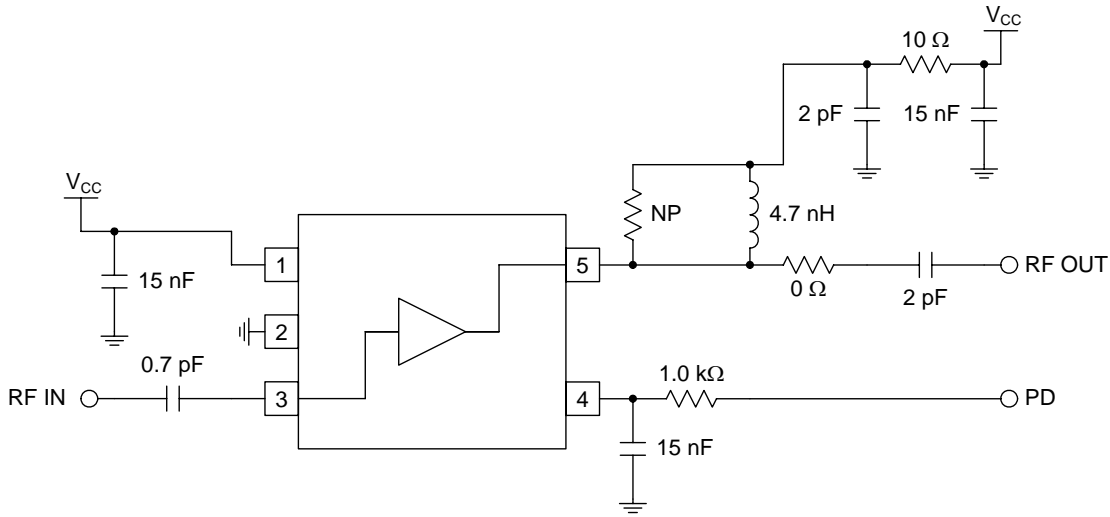

**Evaluation Board Schematic - 1.9GHz**

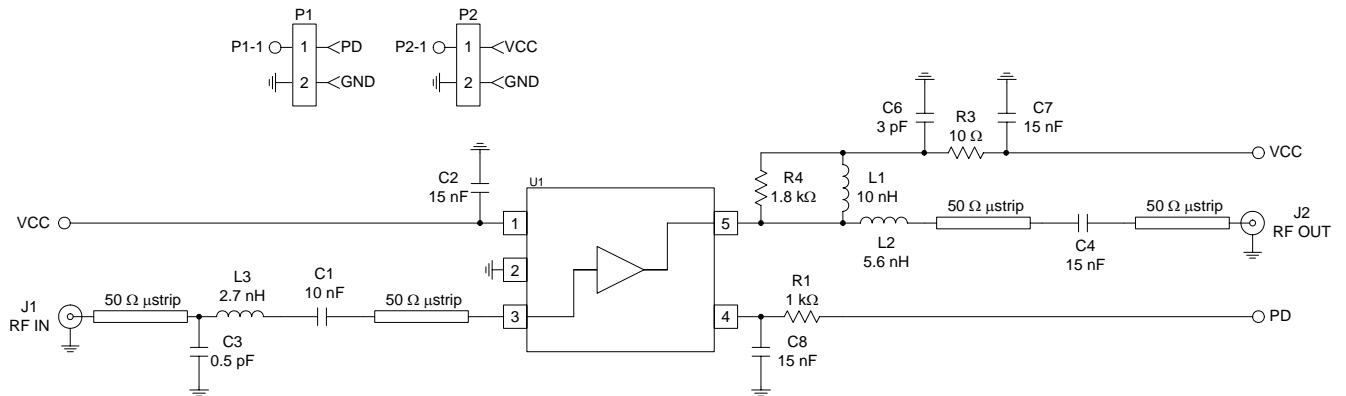

**Evaluation Board Schematic - 2.4GHz**

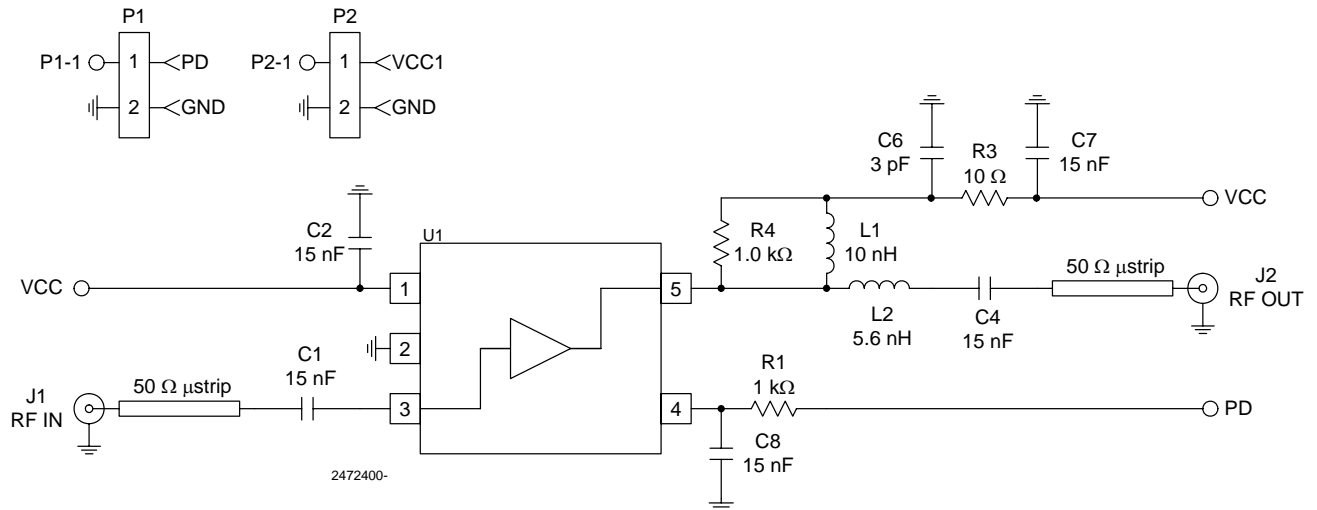

## Evaluation Board Schematic - 4.9GHz to 5.9GHz

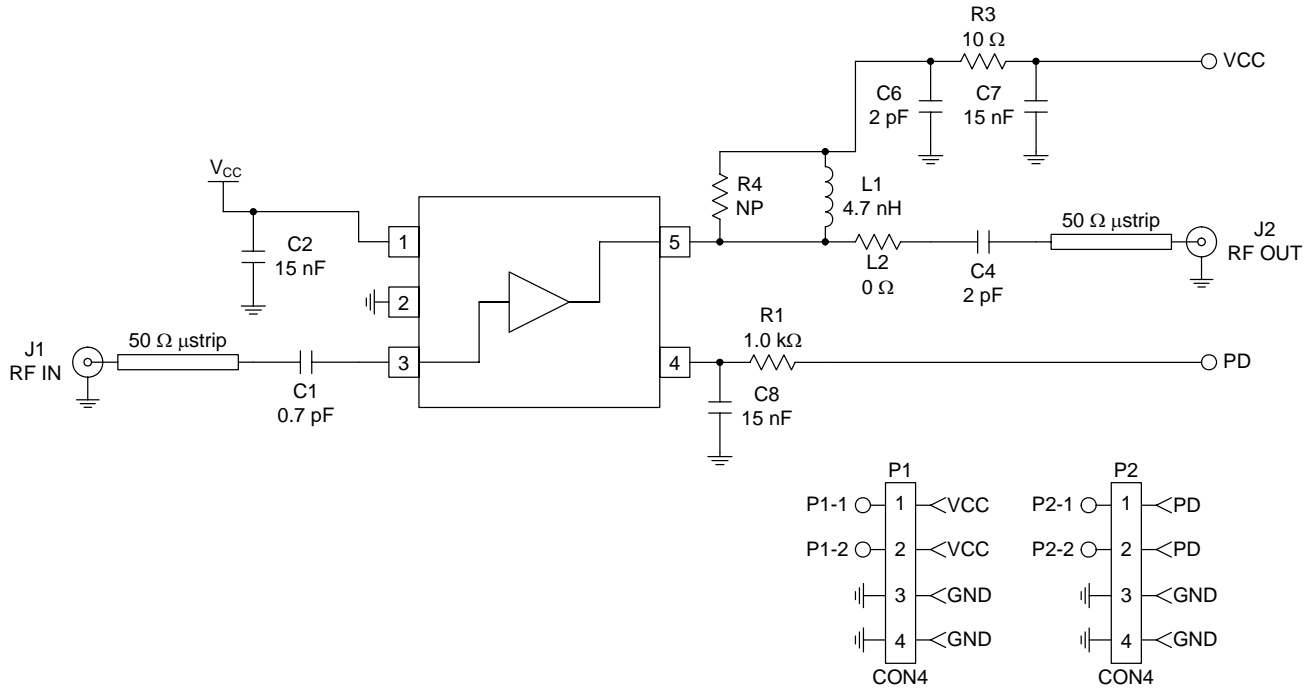



**Evaluation Board Layout - 1.9GHz**  
**Board Size 1.0" x 1.0"**

Board Thickness 0.031"; Board Material FR-4

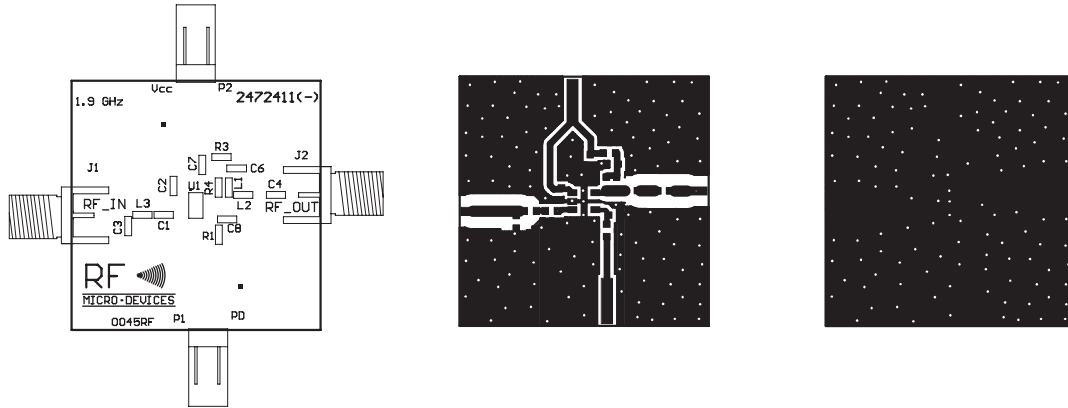

**Evaluation Board Layout - 2.4GHz**  
**Board Size 1.0" x 1.0"**

Board Thickness 0.031"; Board Material FR-4

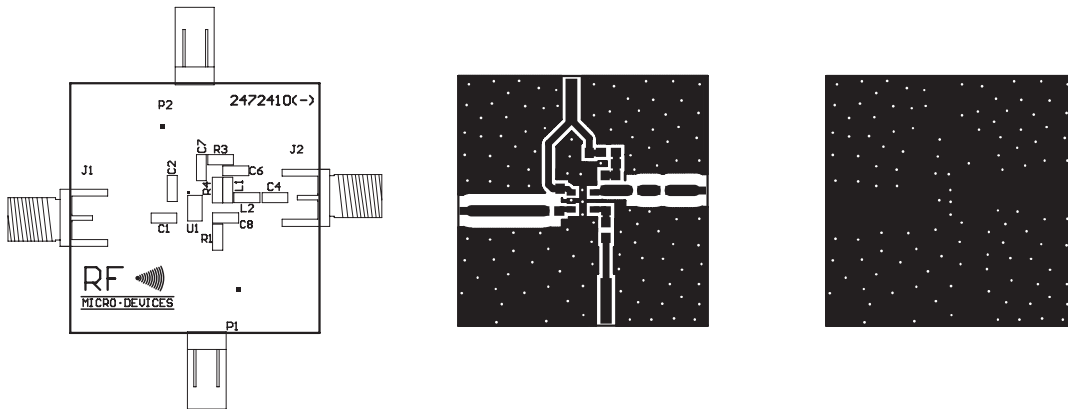

Gain versus Frequency

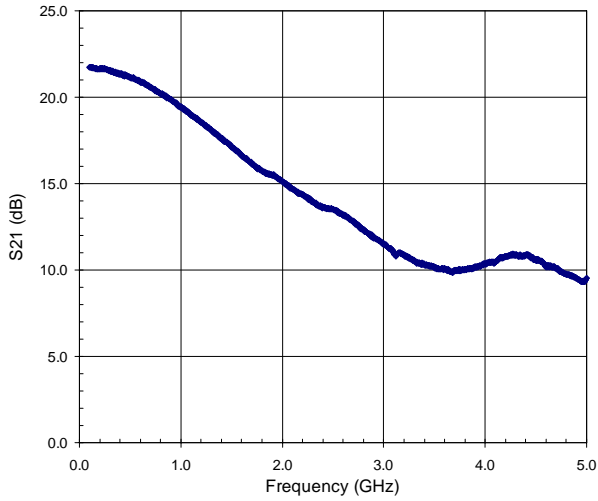

Noise Figure and Gain versus Frequency

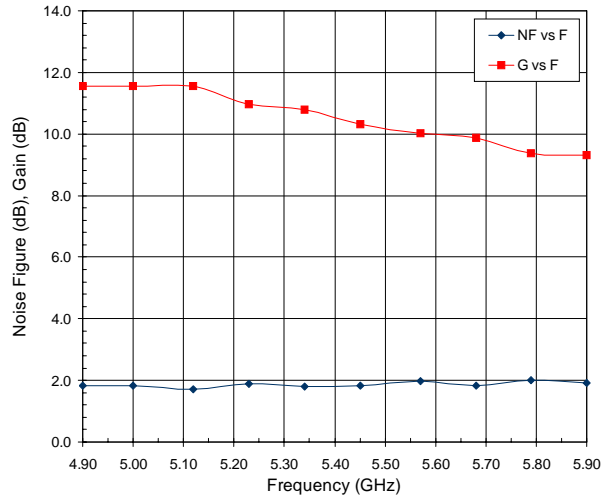

Smith Chart

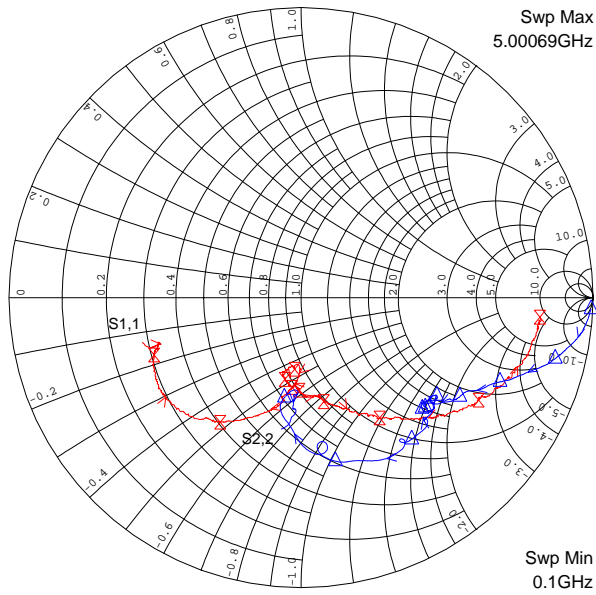

RoHS\* Banned Material Content

RoHS Compliant: Yes  
 Package total weight in grams (g): 0.014  
 Compliance Date Code: N/A  
 Bill of Materials Revision: -  
 Pb Free Category: e3

Bill of Materials	Parts Per Million (PPM)					
	Pb	Cd	Hg	Cr VI	PBB	PBDE
Die	0	0	0	0	0	0
Molding Compound	0	0	0	0	0	0
Lead Frame	0	0	0	0	0	0
Die Attach Epoxy	0	0	0	0	0	0
Wire	0	0	0	0	0	0
Solder Plating	0	0	0	0	0	0

**This RoHS banned material content declaration was prepared solely on information, including analytical data, provided to RFMD by its suppliers, and applies to the Bill of Materials (BOM) revision noted above.**

\* DIRECTIVE 2002/95/EC OF THE EUROPEAN PARLIAMENT AND OF THE COUNCIL of 27 January 2003 on the restriction of the use of certain hazardous substances in electrical and electronic equipment

