

Silicon NPN Power Transistors

2SD1591

DESCRIPTION

- With TO-220Fa package
- DARLINGTON
- Complement to type 2SB1100

APPLICATIONS

- Low frequency power amplification
- Low speed power switching applications

PINNING

PIN	DESCRIPTION
1	Base
2	Collector
3	Emitter

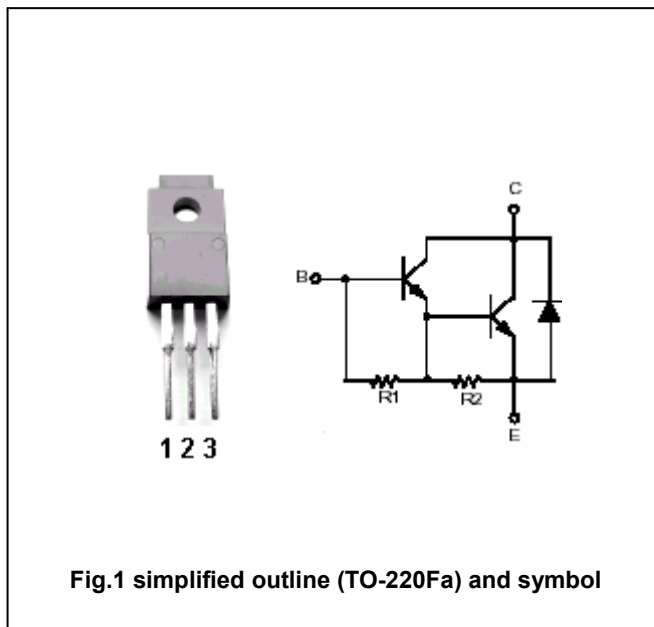

Fig.1 simplified outline (TO-220Fa) and symbol

Absolute maximum ratings(Ta=25°C)

SYMBOL	PARAMETER	CONDITIONS	VALUE	UNIT
V _{CBO}	Collector-base voltage	Open emitter	150	V
V _{CEO}	Collector-emitter voltage	Open base	100	V
V _{EBO}	Emitter-base voltage	Open collector	7	V
I _C	Collector current (DC)		10	A
I _{CM}	Collector current-Peak		15	A
I _B	Base current (DC)		0.5	A
P _C	Collector power dissipation	T _a =25°C	2	W
		T _C =25°C	30	
T _j	Junction temperature		150	°C
T _{stg}	Storage temperature		-55~150	°C

Silicon NPN Power Transistors

2SD1591

CHARACTERISTICS

T_j=25°C unless otherwise specified

SYMBOL	PARAMETER	CONDITIONS	MIN	TYP.	MAX	UNIT
V _{CEO(SUS)}	Collector-emitter sustaining voltage	I _C =0.1A ; I _B =0	100			V
V _{CEsat}	Collector-emitter saturation voltage	I _C =10A; I _B =25mA			1.5	V
V _{BEsat}	Base-emitter saturation voltage	I _C =10A; I _B =25mA			2.0	V
I _{CBO}	Collector cut-off current	V _{CB} =100V; I _E =0			10	μA
I _{CEO}	Collector cut-off current	V _{CE} =100V; I _E =0			500	μA
I _{EBO}	Emitter cut-off current	V _{EB} =7V ; I _C =0			5	mA
h _{FE}	DC current gain	I _C =10A ; V _{CE} =2V	1000		30000	

Silicon NPN Power Transistors

2SD1591

PACKAGE OUTLINE

