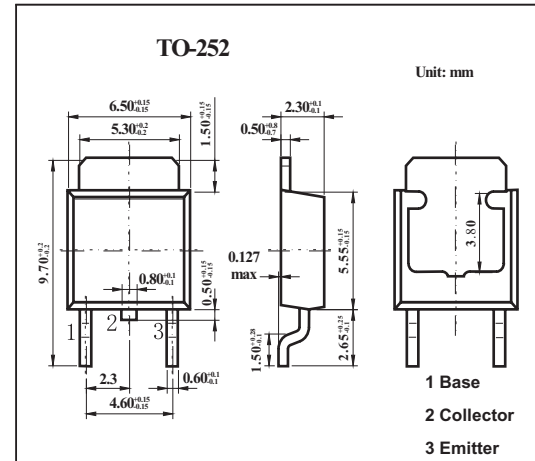

## Silicon PNP Epitaxial Planar Type

## 2SB936A

## ■ Features

- Low collector-emitter saturation voltage  $V_{CE(sat)}$ .
- High-speed switching.

■ Absolute Maximum Ratings  $T_a = 25^\circ\text{C}$ 

Parameter	Symbol	Rating	Unit
Collector-base voltage	$V_{CB0}$	-50	V
Collector-emitter voltage	$V_{CEO}$	-40	V
Emitter-base voltage	$V_{EBO}$	-5	V
Collector current	$I_C$	-10	A
Peak collector current	$I_{CP}$	-20	A
Collector power dissipation	$P_C$	1.3	W
Junction temperature	$T_j$	150	$^\circ\text{C}$
Storage temperature	$T_{stg}$	-55 to +150	$^\circ\text{C}$

■ Electrical Characteristics  $T_a = 25^\circ\text{C}$ 

Parameter	Symbol	Testconditions	Min	Typ	Max	Unit
Collector-emitter voltage	$V_{CEO}$	$I_C = -10\text{mA}$ , $I_B = 0$	-40			V
Collector-base cutoff current	$I_{CB0}$	$V_{CB} = -50\text{V}$ , $I_E = 0$			-50	$\mu\text{A}$
Emitter-base cutoff current	$I_{EBO}$	$V_{EB} = -5\text{V}$ , $I_C = 0$			-50	$\mu\text{A}$
Forward current transfer ratio	$h_{FE}$	$V_{CE} = -2\text{V}$ , $I_C = -3\text{A}$	90		260	V
		$V_{CE} = -2\text{V}$ , $I_C = -0.1\text{A}$	45			
Base-emitter saturation voltage	$V_{BE(sat)}$	$I_C = -10\text{A}$ , $I_B = -0.33\text{A}$			-1.5	V
Collector-emitter saturation voltage	$V_{CE(sat)}$	$I_C = -10\text{A}$ , $I_B = -0.33\text{A}$			-0.6	V
Transition frequency	$f_T$	$V_{CE} = -10\text{V}$ , $I_C = -0.5\text{A}$ , $f = 10\text{MHz}$		100		MHz
Collector output capacitance	$C_{ob}$	$V_{CB} = -10\text{V}$ , $I_E = 0$ , $f = 1.0\text{MHz}$		400		pF
Turn-on time	$t_{on}$	$I_C = -3\text{A}$ , $I_{B1} = -0.1\text{A}$ , $I_{B2} = 0.1\text{A}$ , $V_{CC} = -20\text{V}$		0.1		$\mu\text{s}$
Storage time	$t_{stg}$			0.5		$\mu\text{s}$
Fall time	$t_f$			0.1		$\mu\text{s}$

■  $h_{FE}$  Classification

Rank	Q	P
$h_{FE}$	90~180	130~260