



**DC COMPONENTS CO., LTD.**  
RECTIFIER SPECIALISTS

**BAT42**  
**BAT43**

**TECHNICAL SPECIFICATIONS OF SMALL SIGNAL SCHOTTKY BARRIER DIODES**  
**VOLTAGE - 30 Volts** **CURRENT - 0.2 Amperes**

**FEATURES**

- \* For general purpose applications
- \* Low turn-on voltage.
- \* Fast switching time.
- \* Protected by a PN junction guard ring against excessive voltage, such as electrostatic discharge(ESD).

**MECHANICAL DATA**

- \* Case: Glass sealed case
- \* Lead: MIL-STD-202E, Method 208 guaranteed
- \* Polarity: Color band denotes cathode end
- \* Mounting position: Any
- \* Weight: 0.13 gram

**MAXIMUM RATINGS AND ELECTRICAL CHARACTERISTICS**

Ratings at 25°C ambient temperature unless otherwise specified.  
Single phase, half wave, 60Hz, resistive or inductive load.  
For capacitive load, derate current by 20%.

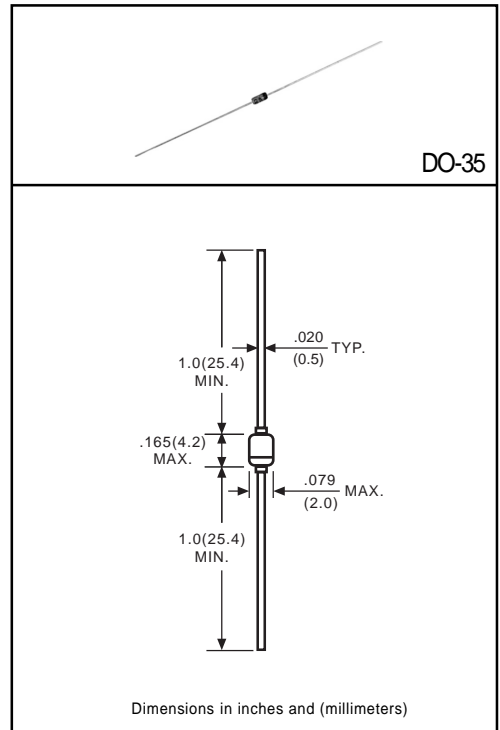

	SYMBOL	BAT42	BAT43	UNITS
Maximum Recurrent Peak Reverse Voltage	V <sub>RRM</sub>	30		Volts
Maximum RMS Voltage	V <sub>RMS</sub>	21		Volts
Maximum DC Blocking Voltage	V <sub>DC</sub>	30		Volts
Maximum Average Forward Rectified Current at T <sub>A</sub> =75°C	I <sub>O</sub>	0.2		Amps
Peak Forward Surge Current 8.3 ms single half sine-wave superimposed on rated load (JEDEC Method)	I <sub>FSM</sub>	4.0		Amps
Maximum Instantaneous Forward Voltage	V <sub>F</sub>	1.0 @ I <sub>F</sub> =0.2A		Volts
		0.4 @ I <sub>F</sub> =0.01A	0.33 @ I <sub>F</sub> =0.002A	
Maximum DC Reverse Current at Rated DC Blocking Voltage	I <sub>R</sub>	@ T <sub>A</sub> = 25°C	0.5	μAmps
		@ T <sub>A</sub> = 100°C	100	
Typical Thermal Resistance (Note1)	R <sub>θJA</sub>	300		°C/W
Typical Junction Capacitance (Note 2)	C <sub>J</sub>	10		pF
Storage Operating Temperature Range	T <sub>J</sub> , T <sub>STG</sub>	-55 to + 125		°C

NOTES : 1. Leads maintained at specified ambient temperature at a distance of 4.0mm from case.  
2. Measured at 1 MHz and applied reverse voltage of 1.0 volts.

# RATING AND CHARACTERISTIC CURVES (BAT42 AND BAT43)

FIG. 1 - TYPICAL INSTANTANEOUS FORWARD CHARACTERISTICS AT DIFFERENT TEMPERATURES

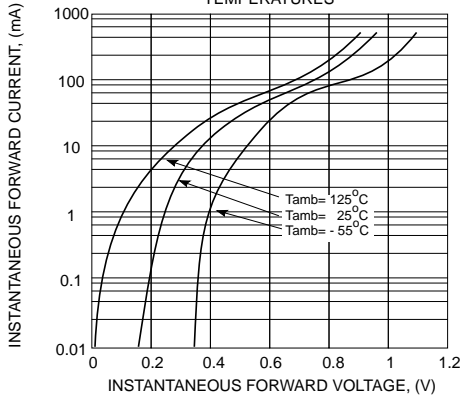

FIG. 2 - TYPICAL INSTANTANEOUS FORWARD CHARACTERISTICS

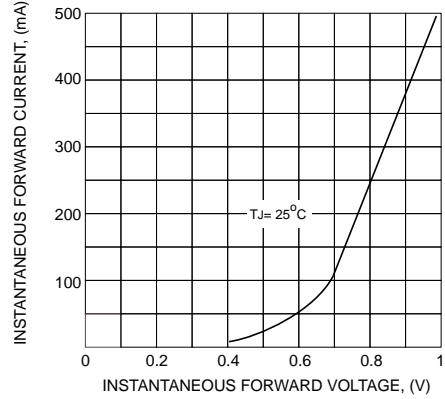

FIG. 3 - TYPICAL REVERSE CURRENT VERSUS AMBIENT TEMPERATURE

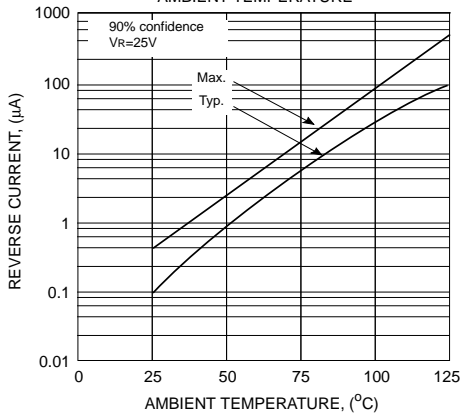

FIG. 4 - TYPICAL REVERSE CHARACTERISTICS

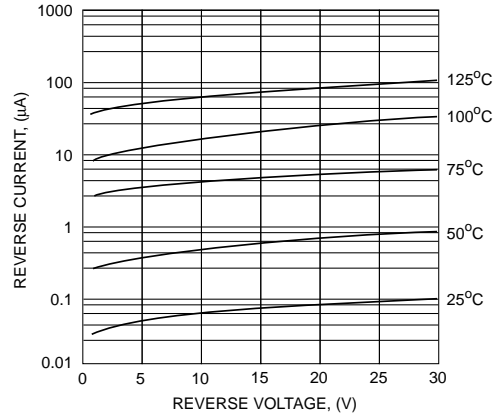

FIG. 5 - TYPICAL JUNCTION CAPACITANCE

