



DC COMPONENTS CO., LTD.

DISCRETE SEMICONDUCTORS

2N3904

TECHNICAL SPECIFICATIONS OF NPN EPITAXIAL PLANAR TRANSISTOR

Description

Designed for general purpose switching and amplifier applications.

Pinning

- 1 = Emitter
- 2 = Base
- 3 = Collector

Absolute Maximum Ratings(T_A=25°C)

Characteristic	Symbol	Rating	Unit
Collector-Base Voltage	V _{CB0}	60	V
Collector-Emitter Voltage	V _{CE0}	40	V
Emitter-Base Voltage	V _{EB0}	6	V
Collector Current	I _C	200	mA
Total Power Dissipation	P _D	625	mW
Junction Temperature	T _J	+150	°C
Storage Temperature	T _{STG}	-55 to +150	°C

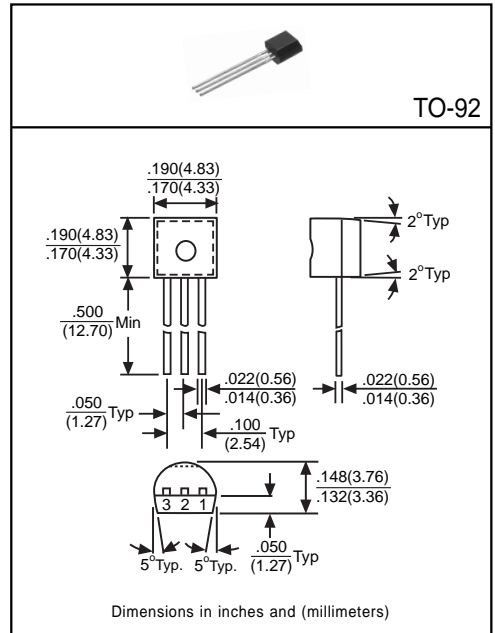

Electrical Characteristics

(Ratings at 25°C ambient temperature unless otherwise specified)

Characteristic	Symbol	Min	Typ	Max	Unit	Test Conditions
Collector-Base Breakdown Voltage	BV _{CB0}	60	-	-	V	I _C =10μA, I _E =0
Collector-Emitter Breakdown Voltage	BV _{CE0}	40	-	-	V	I _C =1mA, I _B =0
Emitter-Base Breakdown Voltage	BV _{EB0}	6	-	-	V	I _E =10μA, I _C =0
Collector Cutoff Current	I _{CX}	-	-	50	nA	V _{CE} =30V, V _{BE} =3V
Collector-Emitter Saturation Voltage ⁽¹⁾	V _{CE(sat)1}	-	-	0.2	V	I _C =10mA, I _B =1mA
	V _{CE(sat)2}	-	-	0.3	V	I _C =50mA, I _B =5mA
Base-Emitter Saturation Voltage ⁽¹⁾	V _{BE(sat)1}	0.65	-	0.85	V	I _C =10mA, I _B =1mA
	V _{BE(sat)2}	-	-	0.95	V	I _C =50mA, I _B =5mA
DC Current Gain ⁽¹⁾	h _{FE1}	40	-	-	-	I _C =0.1mA, V _{CE} =1V
	h _{FE2}	70	-	-	-	I _C =1mA, V _{CE} =1V
	h _{FE3}	100	-	300	-	I _C =10mA, V _{CE} =1V
	h _{FE4}	60	-	-	-	I _C =50mA, V _{CE} =1V
	h _{FE5}	30	-	-	-	I _C =100mA, V _{CE} =1V
Transition Frequency	f _T	300	-	-	MHz	I _C =10mA, V _{CE} =20V, f=100MHz
Output Capacitance	C _{ob}	-	-	4	pF	V _{CB} =5V, f=1MHz, I _E =0

(1) Pulse Test: Pulse Width ≤ 380μs, Duty Cycle ≤ 2%