

# Preset counters electronic

1 preset, timer programmable

Display LED, 5-digits, programmable

## NE210



NE210 - LED Preset counter

### Features

- Preset counter with one preset
- Display 5-digits
- Operating mode, start count, scaling factor programmable
- Connection: Incremental encoder or digital sensors
- Time meter with four time ranges
- Time relay with operation and release delay
- Programmable as a time counter

### Technical data - electrical ratings

Voltage supply	22...50 VAC (50/60 Hz) 85...265 VAC (50/60 Hz) 24 VDC $\pm$ 10 %
Power consumption	5 VA, 5 W
Sensor supply	24 VDC $\pm$ 20 % / 100 mA
Display	LED, 7-segment display
Number of digits	5-digits
Digit height	7.6 mm
Function	Preset counter Main counter with 1 preset
Scaling factor	0.001...99.999
Count modes	Adding or subtracting A-B (difference counting) A+B total (parallel counting) Up/Down A 90° B phase evaluation
Counting frequency	15 Hz, 10 kHz (set by Dip switch)
Operating modes	Main preset, Time meter / time relay
Data memory	>10 years in EEPROM
Reset	Button, electric or automatic
Outputs electronic	NPN / PNP transistor switch
Outputs relay	Potential-free change-over contact
Output holding time	0.01...99.99 s
Standard DIN EN 61010-1	Protection class II Overvoltage category II Pollution degree 2
Emitted interference	DIN EN 61000-6-4
Interference immunity	DIN EN 61000-6-2

### Technical data - electrical ratings

Programmable parameters	Operating modes Sensor logic Scaling factor Count mode Time relay function
Approvals	UL/cUL, CE conform

### Technical data - mechanical design

Operating temperature	0...+50 °C
Storing temperature	-20...+70 °C
Relative humidity	80 % non-condensing
E-connection	Plug-in screw terminals
Core cross-section	1.5 mm <sup>2</sup>
Protection DIN EN 60529	IP 65 face with seal
Operation / keypad	Membrane with softkeys
Housing type	Built-in housing
Dimensions W x H x L	48 x 48 x 108 mm
Installation depth	108 mm
Mounting	Clip frame
Cutout dimensions	45 x 45 mm (+0.6)
Materials	Housing: Makrolon 6485 (PC) Keypad: Polyester
Weight approx.	150 g

# Preset counters electronic

1 preset, timer programmable

Display LED, 5-digits, programmable

NE210

## Part number

NE210.0       AXA1

- Voltage supply**
- 1 22...50 VAC
  - 2 85...265 VAC
  - 3 24 VDC
- Outputs**
- 1 Relay output
  - 2 Relay, signal output PNP
  - 3 Relay, signal output NPN
  - 4 Without relay, signal output PNP

## Accessories

### Adaptor plates (page %S)

Z 118.033	Adaptor plate for screw mount, face 60 x 75 mm
Z 118.034	Adaptor plate for clip mount, face 53.2 x 53.2 mm
Z 118.035	Adaptor plate for clip mount, face 60 x 75 mm

## Connection diagram

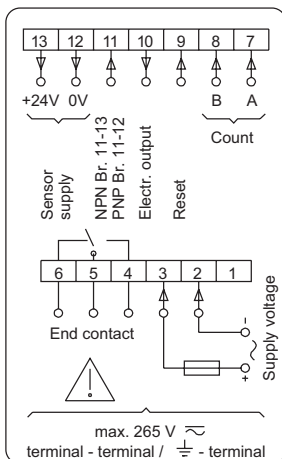

## Block circuit diagram

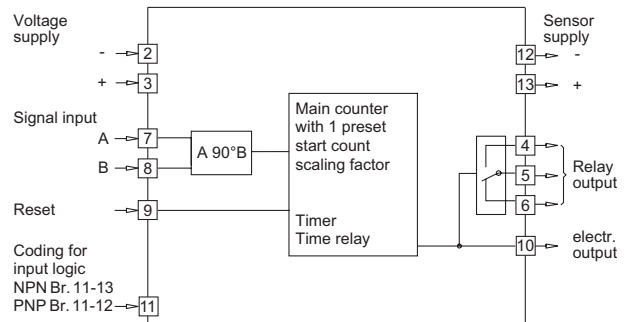

## Trigger level

Optocoupler inputs	Input circuit
Control inputs	PNP- / NPN-logic

Count input	
Trigger current	9...16 mA
Switch-off current	<0.5 mA
Input resistance	1.65 kΩ

Reset input	
Trigger current	5...8 mA
Switch-off current	<0.5 mA
Input resistance	3.3 kΩ

Relay output	Output circuit
Switching voltage max.	250 VAC / 110 VDC
Switching current max.	1 A
Switching capacity max.	150 VA / 30 W
Relay responding time	5 ms

Electronical outputs	Output circuit
<b>PNP-switching transistor</b>	<b>Open collector</b>
Switching voltage	24 VDC ±20%
Switching current max.	10 mA (AC) 50 mA (DC)

<b>NPN-switching transistor</b>	<b>Open collector</b>
Switching voltage max.	35 V
Switching current max.	50 mA

## Dimensions

