

## HVV1011-300 HIGH VOLTAGE, HIGH RUGGEDNESS

*L-Band Avionics Pulsed Power Transistor  
1030/1090 MHz, 50µs Pulse, 5% Duty  
For TCAS, IFF and Mode-S Applications*

### FEATURES

- Silicon MOSFET Technology
- Operation from 24V to 50V
- High Power Gain
- Extreme Ruggedness
- Internal Input and Output Matching
- Excellent Thermal Stability
- All Gold Bonding Scheme

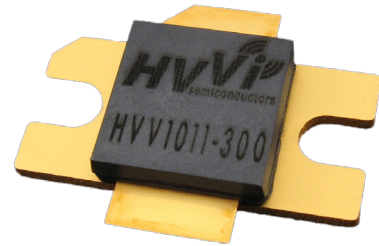

### TYPICAL PERFORMANCE

High voltage vertical technology is well suited for high power pulsed applications in the L-Band including IFF, TCAS and Mode-S applications.

MODE	FREQUENCY (MHz)	VDD (V)	IDQ (mA)	Power (W)	GAIN (dB)	$\eta$ (%)	IRL (dB)	VSWR
Class AB	1400	50	100	120	20	45	-8	20:1

Table 1: Typical RF Performance in broadband test fixture at 25°C temperature with RF pulse conditions of pulse width = 50µs and pulse period = 1ms.

### DESCRIPTION

The high power HVV1011-300 device is an enhancement mode RF MOSFET power transistor designed for pulsed applications in the L-Band from 1030MHz to 1090MHz. The high voltage HVVFET™ technology produces over 300W of pulsed output power while offering high gain, high efficiency, and ease of matching with a 50 V supply. The vertical device structure assures high reliability and ruggedness as the device is specified to withstand a 20:1 VSWR at all phase angles under full rated output power.

### ORDERING INFORMATION

Device Part Number: HVV1011-300

Demo Kit Part Number: HVV1011-300-EK

Available through Richardson Electronics (<http://rfwireless.rell.com/>)

## HVV1011-300 HIGH VOLTAGE, HIGH RUGGEDNESS

*L-Band Avionics Pulsed Power Transistor  
1030/1090 MHz, 50µs Pulse, 5% Duty  
For TCAS, IFF and Mode-S Applications*

### ELECTRICAL CHARACTERISTICS

Symbol	Parameter	Conditions	Min	Typical	Max	Unit
$V_{BR(DSS)}$	Drain-Source Breakdown	VGS=0V, ID=5mA	95	102	-	V
$I_{DSS}$	Drain Leakage Current	VGS=0V, VDS=50V	-	50	200	µA
$I_{GSS}$	Gate Leakage Current	VGS=5V, VDS=0V	-	1	5	µA
$G_P^1$	Power Gain	F=1090MHz	16	18	-	dB
$IRL^1$	Input Return Loss	F=1090MHz	-	-12	-8	dB
$\eta_D^1$	Drain Efficiency	F=1090MHz	43	45	-	%
$VGS(Q)^2$	Gate Quiescent Voltage	VDD=50V, IDQ=100mA	1.1	1.45	1.8	V
VTH	Threshold Voltage	VDD=5V, ID=300µA	0.7	1.2	1.7	V

### PULSE CHARACTERISTICS

Symbol	Parameter	Conditions	Min	Typical	Max	Unit
$T_r^1$	Rise Time	F=1090MHz	-	<35	50	nS
$T_f^1$	Fall Time	F=1090MHz	-	<15	50	nS
$PD^1$	Pulse Droop	F=1090MHz	-	0.3	0.5	dB

### THERMAL PERFORMANCE

Symbol	Parameter	Max	Unit
$\theta_{JC}^1$	Thermal Resistance	0.20	°C/W

### RUGGEDNESS PERFORMANCE

Symbol	Parameter	Test Condition	Max	Units
LMT <sup>1</sup>	Load Mismatch Tolerance	F = 1090 MHz	20:1	VSWR

The HVV1011-300 device is capable of withstanding an output load mismatch corresponding to a 20:1 VSWR at rated output power and nominal operating voltage across the frequency band of operation.

**<sup>1</sup>NOTE: : All parameters measured under pulsed conditions at 275W output power measured at the 10% point of the pulse with pulse width = 50µsec, duty cycle = 5% and VDD = 50V, IDQ = 100mA in a broad-band matched test fixture.**

**<sup>2</sup>NOTE: Amount of gate voltage required to attain nominal quiescent current.**

**HVV1011-300 HIGH VOLTAGE, HIGH RUGGEDNESS**

**L-Band Avionics Pulsed Power Transistor**  
**1030/1090 MHz, 50µs Pulse, 5% Duty**  
**For TCAS, IFF and Mode-S Applications**

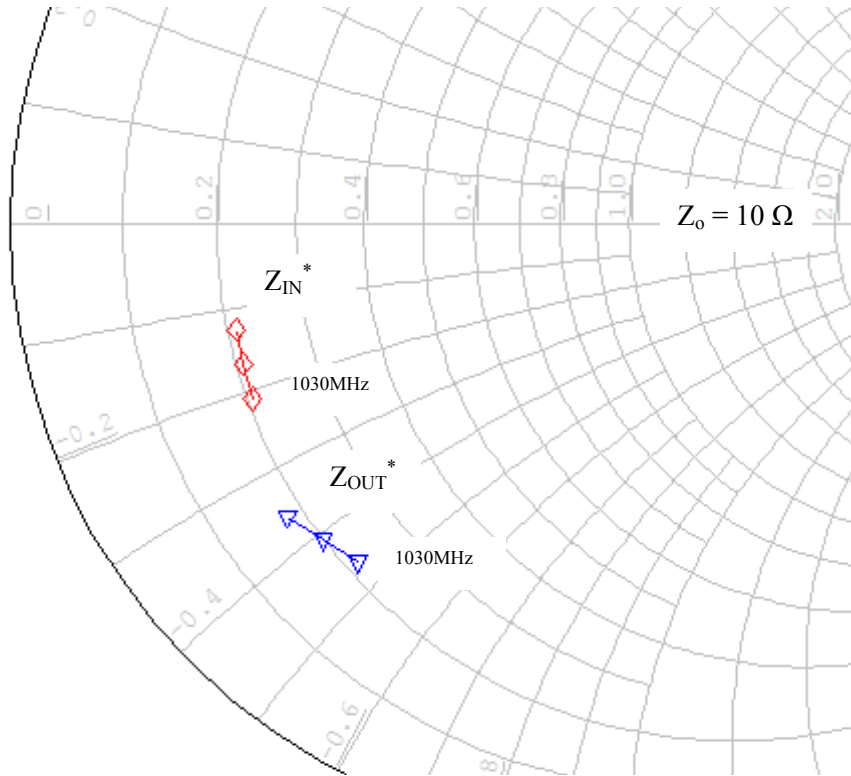

**Test Circuit Impedance**

Frequency	Z <sub>in</sub> '(ohms)	Z <sub>out</sub> '(ohms)
1030MHz	2.06-j2.10	2.17-j4.60
1060MHz	2.09-j1.67	2.00-j4.07
1090MHz	2.10-j1.25	1.80-j3.58

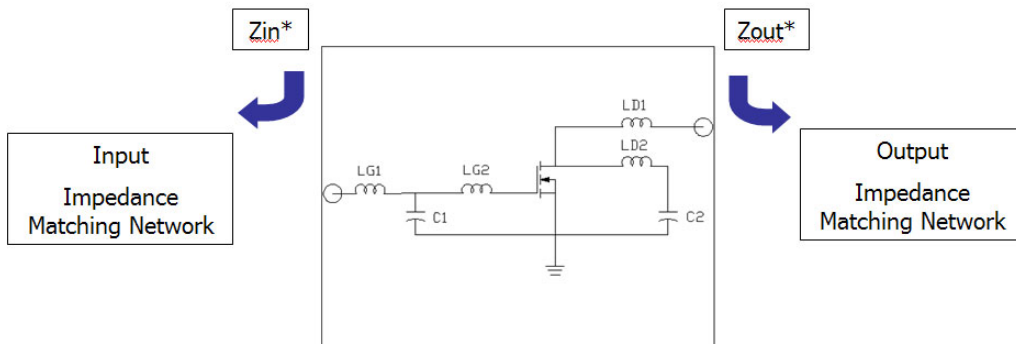

**HVV1011-300 HIGH VOLTAGE, HIGH RUGGEDNESS**

**L-Band Avionics Pulsed Power Transistor**  
**1030/1090 MHz, 50µs Pulse, 5% Duty**  
**For TCAS, IFF and Mode-S Applications**

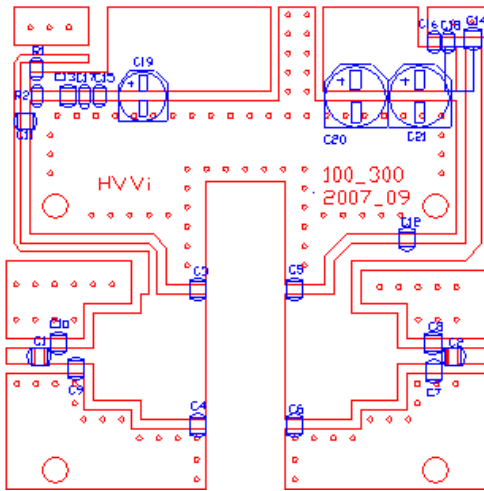

Demonstration Board Outline

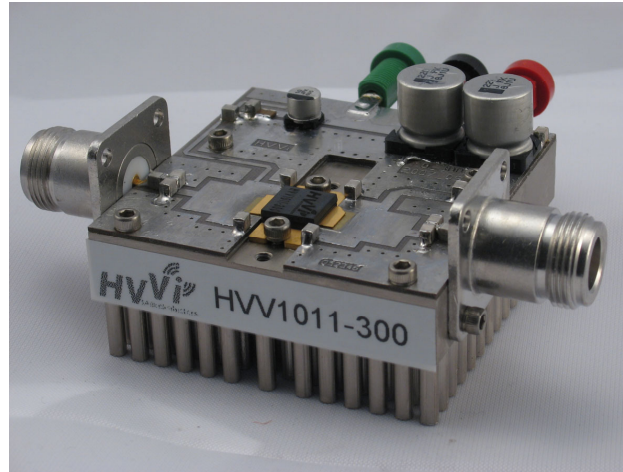

Demonstration Circuit Board Picture

(AutoCAD Files for Demonstration Board available online at [www.hvvi.com/products](http://www.hvvi.com/products))

Part	Description	Part Number	Manufacturer
C1, C2:	100 pF ATC 100B Chip Capacitor	100B101JP500X	ATC
C3,C4:	3.9 pF ATC 100B Chip Capacitor	100B3R9JP500X	ATC
C5:	5.6 pF ATC 100B Chip Capacitor	100B5R6JP500X	ATC
C6,C9:	4.7 pF ATC 100B Chip Capacitor	100B4R7JP500X	ATC
C7,C8:	2.0 pF ATC 100B Chip Capacitor	100B2R0JP500X	ATC
C10:	2.4 pF ATC 100B Chip Capacitor	100B2R4JP500X	ATC
C11:	15 pF ATC 100B Chip Capacitor	100B150JP500X	ATC
C12:	27 pF ATC 100B Chip Capacitor	100B270JP500X	ATC
C13, C14:	47 pF ATC 100B Chip Capacitor	100B470JP500X	ATC
C15, C16:	10K pF 100V Chip Capacitor (X7R 1206)	C1206C103K1RACTU	Kemet
C17, C18:	1K pF 100V Chip Capacitor (X7R 1206)	C1206C102K1RACTU	Kemet
C19:	10 uF 63V Elect FK SMD	PCE3479CT-ND	Digi Key
C20, C21:	100 uF 63V Elect FK SMD	PCE3483CT-ND	Digi Key
R1:	10 Ohms Chip Resistor (1206)	ERJ8GEYJ100V	Panasonic
R2:	1.0 K Ohms Chip Resistor (1206)	ERJ8GEYJ102V	Panasonic
RF Connectors	Type "N" RF connectors	5919CC-TB-7	Coaxicom
DC Drain Conn	Connector Jack Banana Nylon Red	J151-ND	DIGI-KEY
DC Ground Conn	Connector Jack Banana Nylon Black	J152-ND	DIGI-KEY
DC Gate Conn.	Connector Jack Banana Nylon Green	J153-ND	DIGI-KEY
PCB Board	PCB: Arlon, 30 mils thick, 2.55 Dielectric, 2 oz Copper # (DS2346)		DS Electronics
Device Clamp	Cool Innovation Nylon Clamp Foot	FXT000158 Rev. B	Cool Innovation
Heat Sink	Cool Innovations Aluminum Heat Sink	3-252510RS3411	Cool Innovation
S.S. Screws (4)	4-40 X 1/4 Stainless Steel Socket Hex Head	P242393	Copper State Bolt
Alloy Screws (4)	4-40 X 1/2 Alloy Socket Cap screw Hex	SCAS-0440-08C	Small Parts Inc
Metal Washer (6)	#4 Washer Zinc PLTD Steel Lock	ZSLW-004-M	Small Parts Inc
Alloy Screws (2)	4-40 X 3/4 Alloy Socket Cap Screw Head	SCAS-0440-12M	Small Parts Inc

HVV1011-300 Demonstration Circuit Board Bill of Materials



The innovative Semiconductor Company!

**HVV1011-300 HIGH VOLTAGE, HIGH RUGGEDNESS**

**L-Band Avionics Pulsed Power Transistor**  
**1030/1090 MHz, 50µs Pulse, 5% Duty**  
**For TCAS, IFF and Mode-S Applications**

**PACKAGE DIMENSIONS**

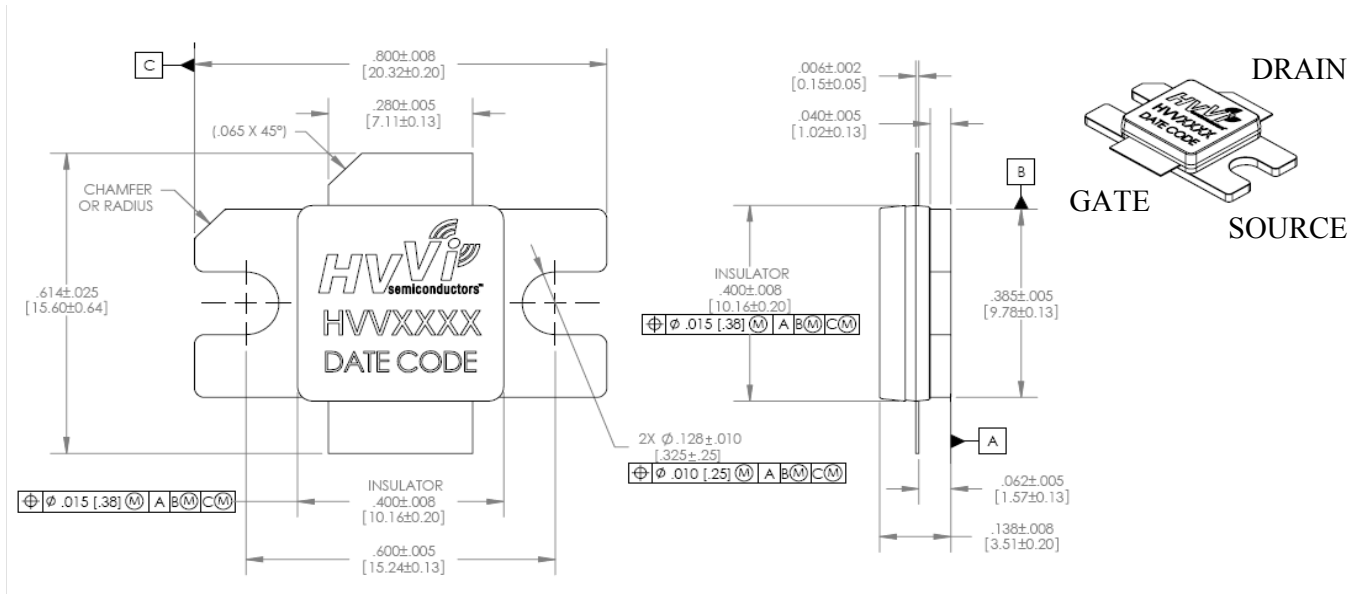

**Note: Drawing is not actual size.**

HVVi Semiconductors, Inc. (HVVi) reserves the right to make changes to information published in this document at any time and without notice. This document supersedes and replaces all information supplied prior to the publication hereof. Information in this document is believed to be accurate and reliable. However, HVVi does not give any representations or warranties, either express or implied, as to the accuracy or completeness of such information and shall have no liability for the consequences of use of such information. Use of HVVi products as critical components in life support systems is not authorized. No licenses, either express or implied, are conveyed under any HVVi intellectual property rights, including any patent rights. The HVVi name and logo are trademarks of HVVi Semiconductors, Inc.