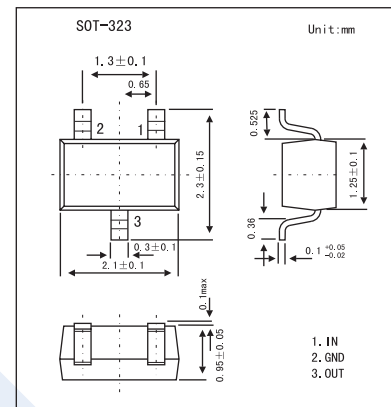

Digital Transistors

DTA114EUA

■ Features

- PNP Epitaxial Planar Silicon Transistor (Resistor Built-In Typ.)
- Built-In Bias Resistors Enable The Configuration of An Inverter Circuit Without Connecting External Input Resistors
(See Equivalent Circuit).

■ Absolute Maximum Ratings $T_a = 25^\circ\text{C}$

Parameter	Symbol	Rating	Unit
Supply Voltage	V_{CC}	-50	V
Input Voltage	V_{IN}	-40 to +10	V
Output Current	I_o	-50	mA
	$I_{C(Max)}$	-100	
Power Dissipation	P_D	200	mW
Junction temperature	T_j	150	$^\circ\text{C}$
Storage temperature	T_{stg}	-55 to +150	$^\circ\text{C}$

■ Electrical Characteristics $T_a = 25^\circ\text{C}$

Parameter	Symbol	Testconditions	Min	Typ	Max	Unit
Input Voltage	$V_{I(off)}$	$V_{CC} = -5V, I_o = -100 \mu A$			-0.5	V
	$V_{I(on)}$	$V_o = -0.3V, I_o = -10mA$	-3			
Output Voltage	$V_{O(on)}$	$I_o/I_i = -10mA/-0.5mA$			-0.3	V
Input Current	I_i	$V_i = -5V$			-0.88	mA
Output Current	$I_{O(off)}$	$V_{CC} = -50V, V_i = 0V$			-0.5	μA
DC Current Gain	G_I	$V_o = -5V, I_o = -5mA$	30			
Input Resistance	R_1		7	10	13	$k\Omega$
Resistance Ratio	R_2/R_1		0.8	1	1.2	
Transistion Frequency	f_t^*	$V_{CE} = -10V, I_E = 5mA, f = 100MHz$		250		MHz

* Characteristics of built-in transistor

■ Marking

Marking	14
---------	----

DTA114EUA

■ Equivalent Circuit

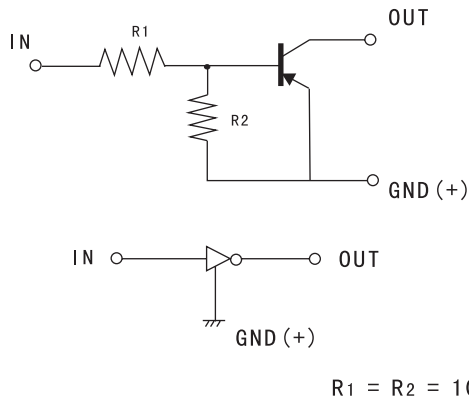

■ Electrical Characteristics Curves

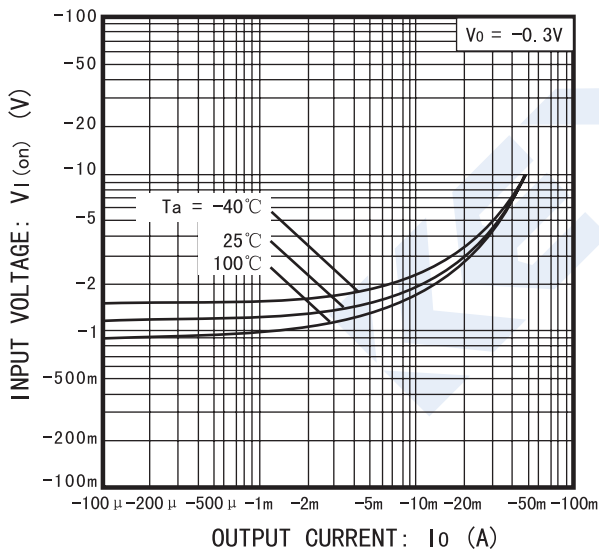

Input voltage vs. Output current (ON characteristics)

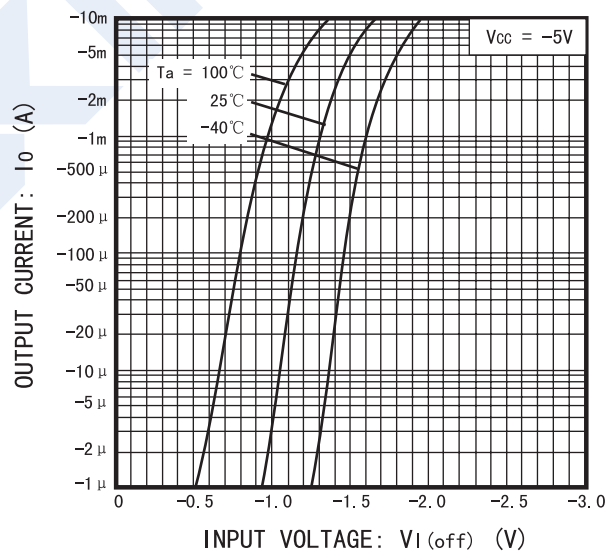

Output current vs. Input voltage (OFF characteristics)

DTA114EUA

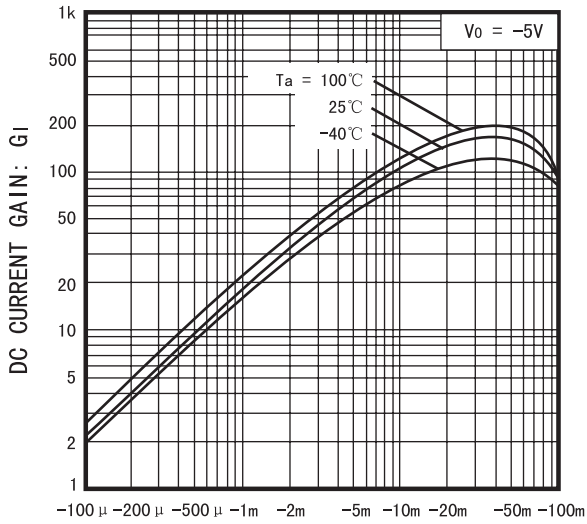

OUTPUT CURRENT: I_o (A)
DC current gain vs. Output current

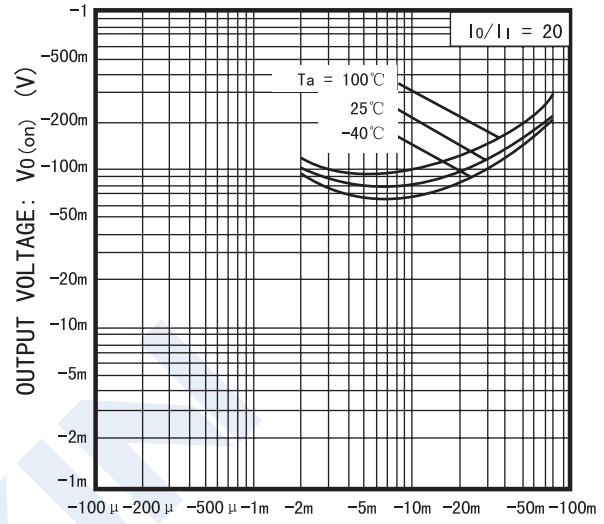

OUTPUT CURRENT: I_o (A)
Output voltage vs. Output current