

Silicon NPN Power Transistors

2N5293 2N5295 2N5297

DESCRIPTION

- With TO-220 package
- High power dissipation

APPLICATIONS

- Power amplifier and medium speed switching applications

PINNING

PIN	DESCRIPTION
1	Base
2	Collector;connected to mounting base
3	Emitter

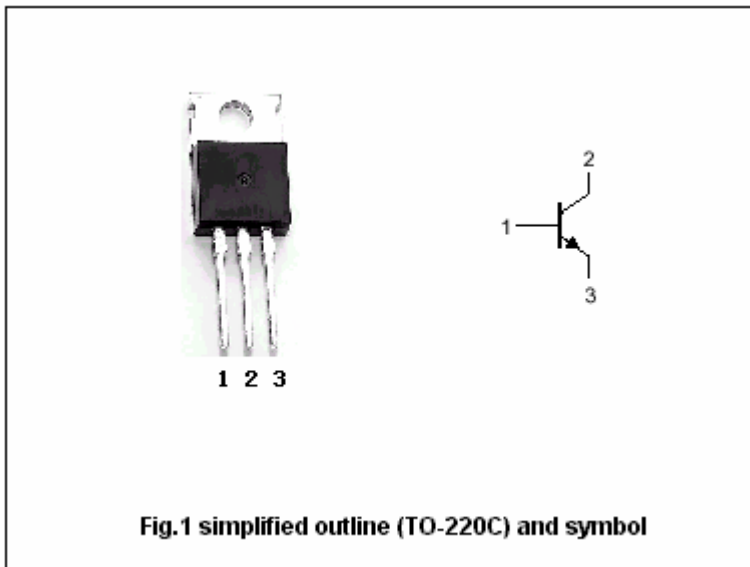

Fig.1 simplified outline (TO-220C) and symbol

Absolute maximum ratings(Ta=25 )

SYMBOL	PARAMETER	CONDITIONS	VALUE	UNIT
V <sub>CBO</sub>	Collector-base voltage	2N5293	80	V
		2N5295	60	
		2N5297	80	
V <sub>CEO</sub>	Collector-emitter voltage	2N5293	70	V
		2N5295	40	
		2N5297	60	
V <sub>EBO</sub>	Emitter-base voltage	Open collector	7	V
I <sub>C</sub>	Collector current		4	A
I <sub>B</sub>	Base current		2	A
P <sub>T</sub>	Total power dissipation	T <sub>C</sub> =25	36	W
T <sub>j</sub>	Junction temperature		150	
T <sub>stg</sub>	Storage temperature		-65~150	

THERMAL CHARACTERISTICS

SYMBOL	PARAMETER	MAX	UNIT
R <sub>th j-c</sub>	Thermal resistance from junction to case	3.47	/W

## Silicon NPN Power Transistors

## 2N5293 2N5295 2N5297

## CHARACTERISTICS

T<sub>j</sub>=25 unless otherwise specified

SYMBOL	PARAMETER	CONDITIONS	MIN	TYP.	MAX	UNIT
V <sub>CEO(SUS)</sub>	Collector-emitter sustaining voltage	2N5293	I <sub>C</sub> =0.1A ; I <sub>B</sub> =0	70		V
		2N5295		40		
		2N5297		60		
V <sub>CEsat</sub>	Collector-emitter saturation voltage	2N5293	I <sub>C</sub> =0.5A; I <sub>B</sub> =0.05A		1.0	V
		2N5295	I <sub>C</sub> =1.0A; I <sub>B</sub> =0.1A			
		2N5297	I <sub>C</sub> =1.5A; I <sub>B</sub> =0.15A			
V <sub>BE</sub>	Base-emitter on voltage	2N5293	I <sub>C</sub> =0.5A ; V <sub>CE</sub> =4V		1.1	V
		2N5295	I <sub>C</sub> =1.0A ; V <sub>CE</sub> =4V		1.3	
		2N5297	I <sub>C</sub> =1.5A ; V <sub>CE</sub> =4V		1.5	
I <sub>CEV</sub>	Collector cut-off current	2N5293/5297	V <sub>CE</sub> =65V; V <sub>BE</sub> =1.5V T <sub>C</sub> =150		0.5 3.0	mA
		2N5295	V <sub>CE</sub> =35V; V <sub>BE</sub> =1.5V T <sub>C</sub> =150		2.0 5.0	
I <sub>CER</sub>	Collector cut-off current	2N5293/5297	V <sub>CE</sub> =50V; R <sub>BE</sub> =100 T <sub>C</sub> =150		0.5 2.0	mA
I <sub>EBO</sub>	Emitter cut-off current	2N5295	V <sub>EB</sub> =7V; I <sub>C</sub> =0		1.0	mA
		2N5293/5297	V <sub>EB</sub> =5V; I <sub>C</sub> =0			
h <sub>FE</sub>	DC current gain	2N5293	I <sub>C</sub> =0.5A ; V <sub>CE</sub> =4V	30	120	
		2N5295	I <sub>C</sub> =1.0A ; V <sub>CE</sub> =4V			
		2N5297	I <sub>C</sub> =1.5A ; V <sub>CE</sub> =4V	20	80	
f <sub>T</sub>	Transition frequency		I <sub>C</sub> =0.2A ; V <sub>CE</sub> =4V	0.8		MHz
t <sub>on</sub>	Turn-on time	2N5293	I <sub>C</sub> =0.5A; I <sub>B</sub> =0.05A; V <sub>CC</sub> =30V		5.0	μs
		2N5295	I <sub>C</sub> =1.0A; I <sub>B</sub> =0.1A; V <sub>CC</sub> =30V			
		2N5297	I <sub>C</sub> =1.5A; I <sub>B</sub> =0.15A; V <sub>CC</sub> =30V			
t <sub>off</sub>	Turn-off time	2N5293	I <sub>C</sub> =0.5A; I <sub>B</sub> =0.05A; V <sub>CC</sub> =30V		15	μs
		2N5295	I <sub>C</sub> =1.0A; I <sub>B</sub> =0.1A; V <sub>CC</sub> =30V			
		2N5297	I <sub>C</sub> =1.5A; I <sub>B</sub> =0.15A; V <sub>CC</sub> =30V			

Silicon NPN Power Transistors

2N5293 2N5295 2N5297

PACKAGE OUTLINE

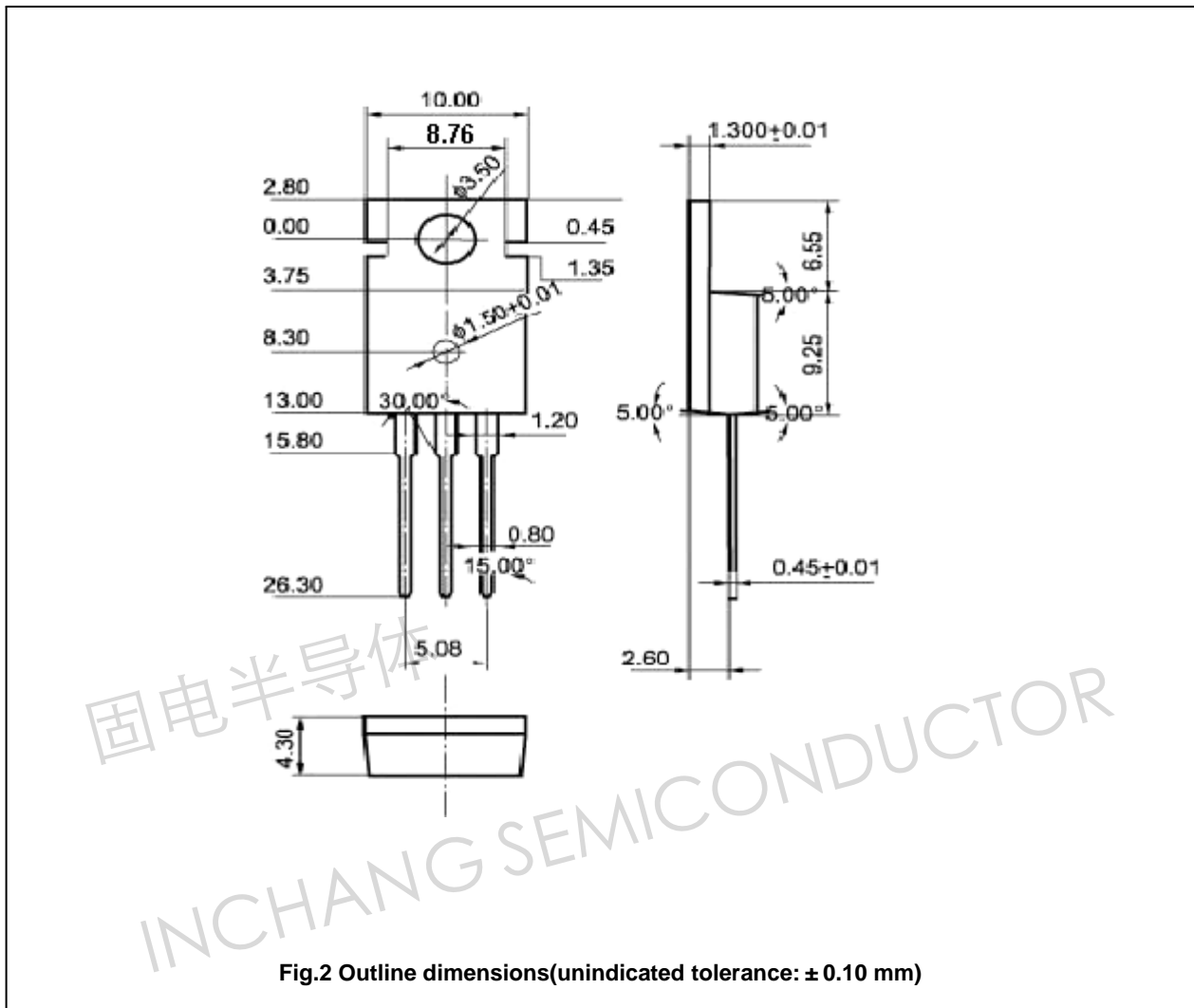

Fig.2 Outline dimensions(unindicated tolerance: ± 0.10 mm)