

Constant Voltage and Constant Current Controller for Adaptors and Battery Chargers

IK3051A

Description

IK3051A is a highly integrated solution for SMPS applications requiring constant voltage and constant current mode.

IK3051A integrates one voltage reference, two operational amplifiers (with ORed outputs – common collectors), and a current sensing circuit.

The voltage reference combined with one operational amplifier makes it an ideal voltage controller, and the other low voltage reference combined with the other operational amplifier makes it an ideal current limiter for output low side current sensing.

The current threshold is fixed and precise.

The only external components are:

- A resistor bridge to be connected to the output of the power supply (adapter, battery charger) to set the voltage regulation by dividing the desired output voltage to match the internal voltage reference value.
- A sense resistor having a value and allowable dissipation power which need to be chosen according to the internal voltage threshold.
- Optional compensation components (R and C).

IK3051A, is ideal for smallest package available, is ideal for space shrunked applications such as adaptors and battery chargers.

Features

- CONSTANT VOLTAGE AND CONSTANT CURRENT CONTROL
- LOW VOLTAGE OPERATION
- PRECISION INTERNAL COMPONENT COUNT
- CURRENT SINK OUTPUT STAGE
- EASY COMPENSATION
- LOW AC MAINS VOLTAGE REJECTION

Pin Definitions and Functions

SOT23-6 Pinout

| Name | Pin# | Type | Function | | | | | | | | |
|--------|------|---------------------|--|-----|---|---------------------|----------------------------------|--------|---|--------------|---------------------------------------|
| Vcc | 6 | Power Supply | Positive Power Supply Line | | | | | | | | |
| GND | 2 | Power Supply | Ground Line. 0V Reference For All Voltages | | | | | | | | |
| Vctrl | 1 | Analog Input | Input Pin of the Voltage Control Loop | | | | | | | | |
| Ictrl | 4 | Analog Input | Input Pin of the Current Control Loop | Out | 3 | Current Sink Output | Output Pin. Sinking Current Only | Vsense | 5 | Analog Input | Input Pin of the Current Control Loop |
| Out | 3 | Current Sink Output | Output Pin. Sinking Current Only | | | | | | | | |
| Vsense | 5 | Analog Input | Input Pin of the Current Control Loop | | | | | | | | |

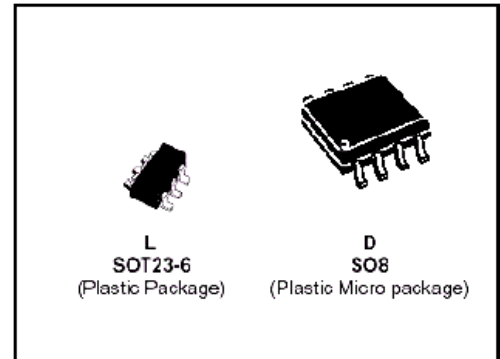

PIN CONNECTIONS (top view)

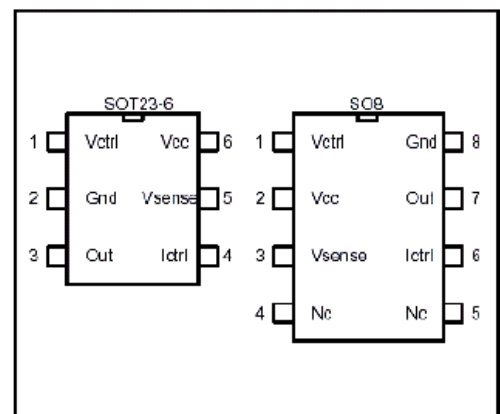

INTERNAL SCHEMATIC

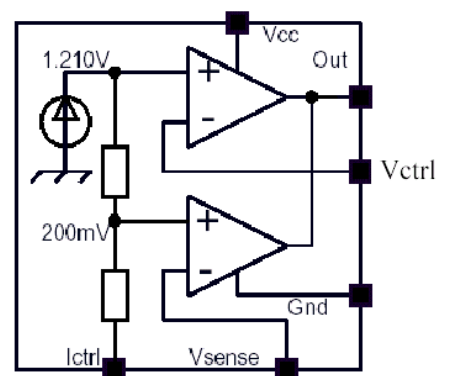

Absolute Maximum Ratings

| Symbol | Parameter | Value | Unit |
|-----------------|--------------------------------------|-------------------------|------|
| V _{cc} | DC Supply Voltage | 14 | V |
| V _i | Input Voltage | -0.3 to V _{cc} | V |
| T _{op} | Operating Free Air Temperature Range | 0 to 85 | °C |
| T _j | Maximum Junction Temperature | 150 | °C |

Operation Conditions

| Symbol | Parameter | Value | Unit |
|-----------------|----------------------|-----------|------|
| V _{cc} | DC Supply Conditions | 2.5 to 12 | V |

Electrical Characteristics

T_{amb} = 25°C and V_{cc} = +5V (unless otherwise specified)

| Symbol | Parameter | Test Condition | Min | Typ | Max | Unit |
|----------------------------------|---|--|----------------|------------|----------------|-------|
| Total Current Consumption | | | | | | |
| I _{cc} | Total Supply Current – not taking the output sinking current into account | T _{amb} 0 < T _{amb} < 85 °C | | 1.1 1.2 | 2 | mA |
| Voltage Control Loop | | | | | | |
| G _{mv} | Transconduction Gain (V _{ctrl}). Sink Current Only ¹⁾ | T _{amb} 0 < T _{amb} < 85 °C | 1 | 3.5 2.5 | | mA/mV |
| V _{ref} | Voltage Control Loop Reference ²⁾ | T _{amb} 0 < T _{amb} < 85 °C | 1.204 1.186 | 1.21 | 1.216 1.234 | V |
| I _{ibv} | Input Bias Current (V _{ctrl}) | T _{amb} 0 < T _{amb} < 85 °C | | 50 100 | | nA |
| Current Control Loop | | | | | | |
| G _{mi} | Transconduction Gain (I _{ctrl}). Sink Current Only ³⁾ | T _{amb} 0 < T _{amb} < 85 °C | 1.5 | 7 | | mA/mV |
| V _{sense} | Current Control Loop Reference ⁴⁾ | I _{out} = 2.5 mA T _{amb} 0 < T _{amb} < 85 °C | 196 192 | 200 | 204 208 | mV |
| I _{ibi} | Current out of pin I _{ctrl} at -200mV | T _{amb} 0 < T _{amb} < 85 °C | | 25 50 | | μA |
| Output Stage | | | | | | |
| V _{ol} | Low output voltage at 10 mA sinking current | T _{amb} 0 < T _{amb} < 85 °C | | 200 | | mV |
| I _{os} | Output Short Circuit Current. Output to V _{cc} . Sink Current Only | T _{amb} 0 < T _{amb} < 85 °C | | 27 35 | 50 | mA |

1. If the voltage on V_{ctrl} (the negative input of the amplifier) is higher than the positive amplifier input (V_{ref}=1.210V), and it is increased by 1mV, the sinking current at the output OUT will be increased by 3.5mA.

2. The internal Voltage Reference is set at 1.210V (bandgap reference). The voltage control loop precision takes into account the cumulative effects of the internal voltage reference deviation as well as the input offset voltage of the trans-conductance operational amplifier. The internal Voltage Reference is fixed by bandgap, and trimmed to 0.5% accuracy at room temperature.

3. When the positive input at I_{ctrl} is lower than -200mV, and the voltage is decreased by 1mV, the sinking current at the output OUT will be increased by 7mA.

4. The internal current sense threshold is set to -200mV. The current control loop precision takes into account the cumulative effects of the internal voltage reference deviation as well as the input offset voltage of the trans-conduction operational amplifier.

Figure 1 : Typical Adapter or Battery Charger Application Using IK3051A

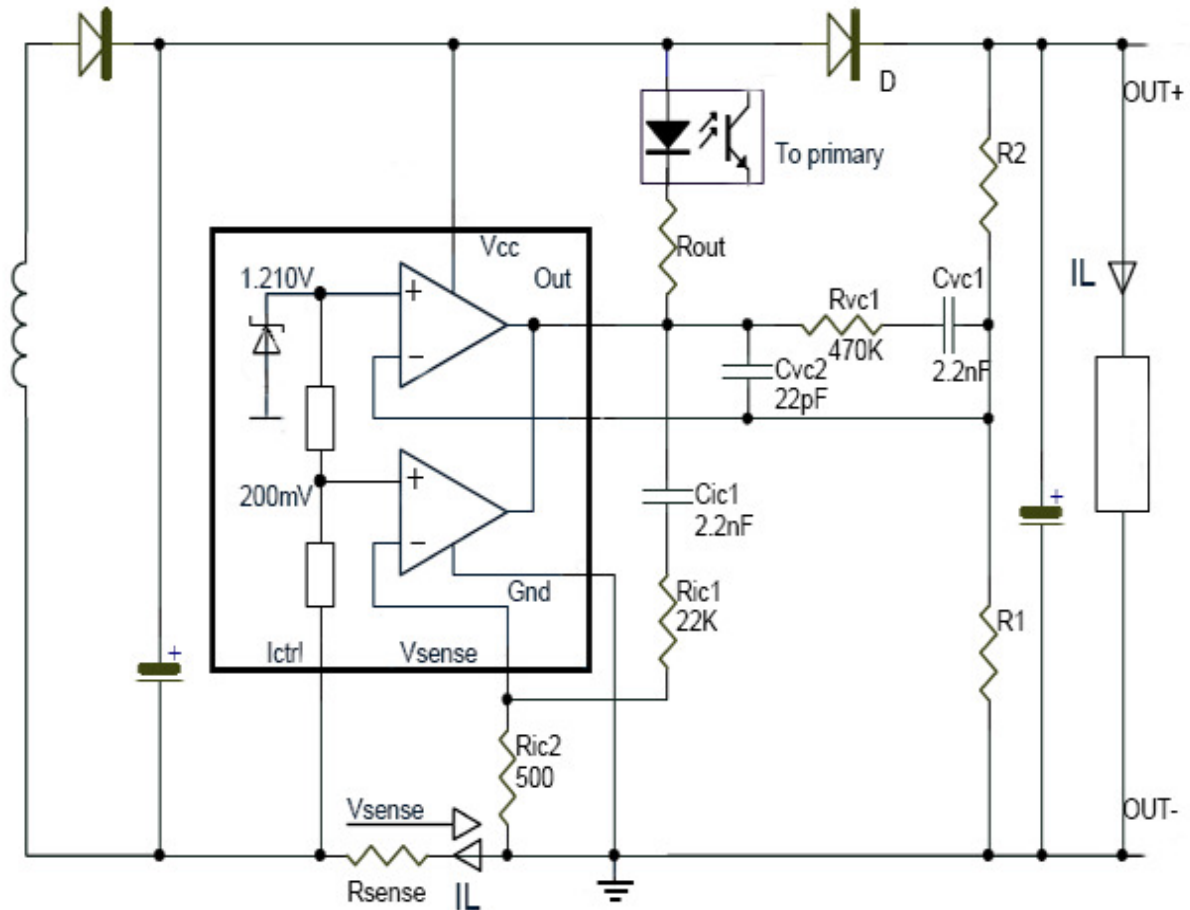

In

the above application schematic, the IK3051A is used on the secondary side of a flyback adapter (or battery charger) to provide an accurate control of voltage and current. The above feedback loop is made with an optocoupler.

Figure 3: Vref vs Ambient Temperature

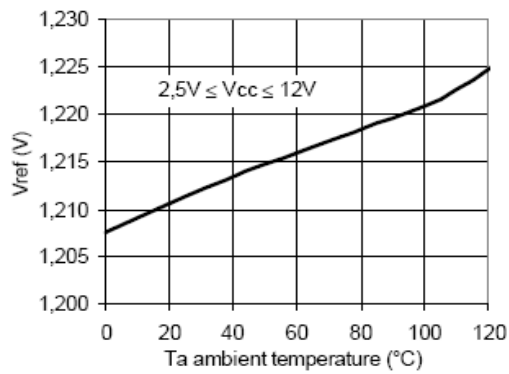

Figure 4: Vsense pin input bias current vs Ambient Temperature

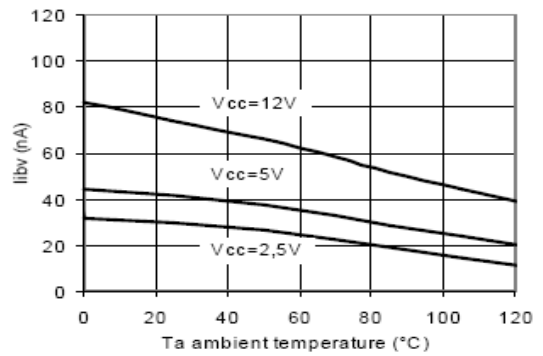

Figure 5: Output short circuit current vs Ambient Temperature

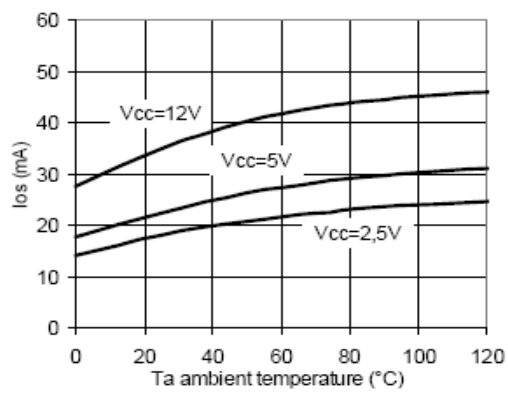

Figure 6: Vsense vs Ambient Temperature

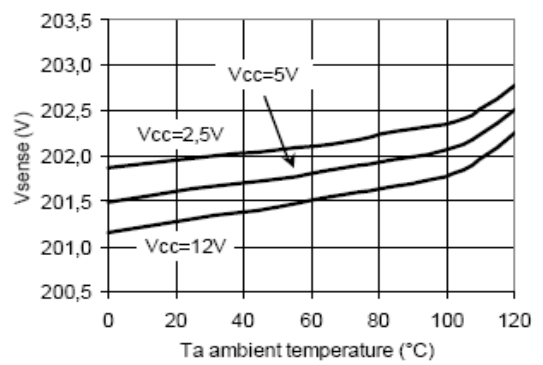

Figure 7: Ictrl pin input bias current vs Ambient Temperature

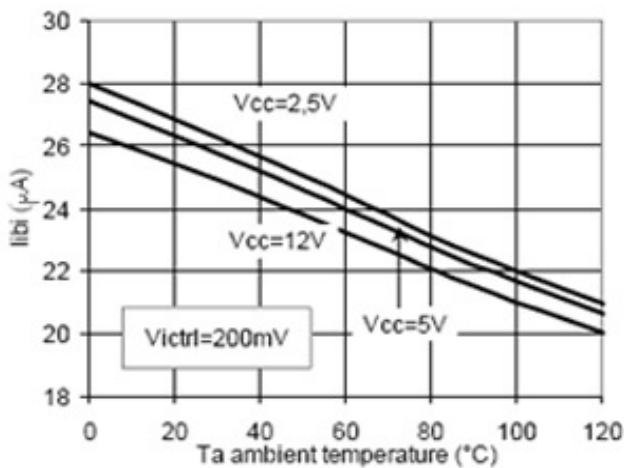
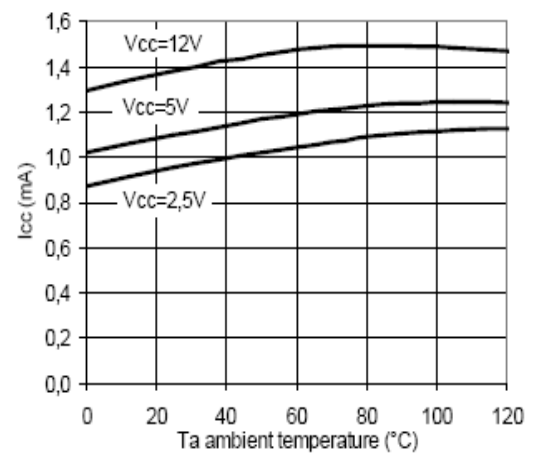
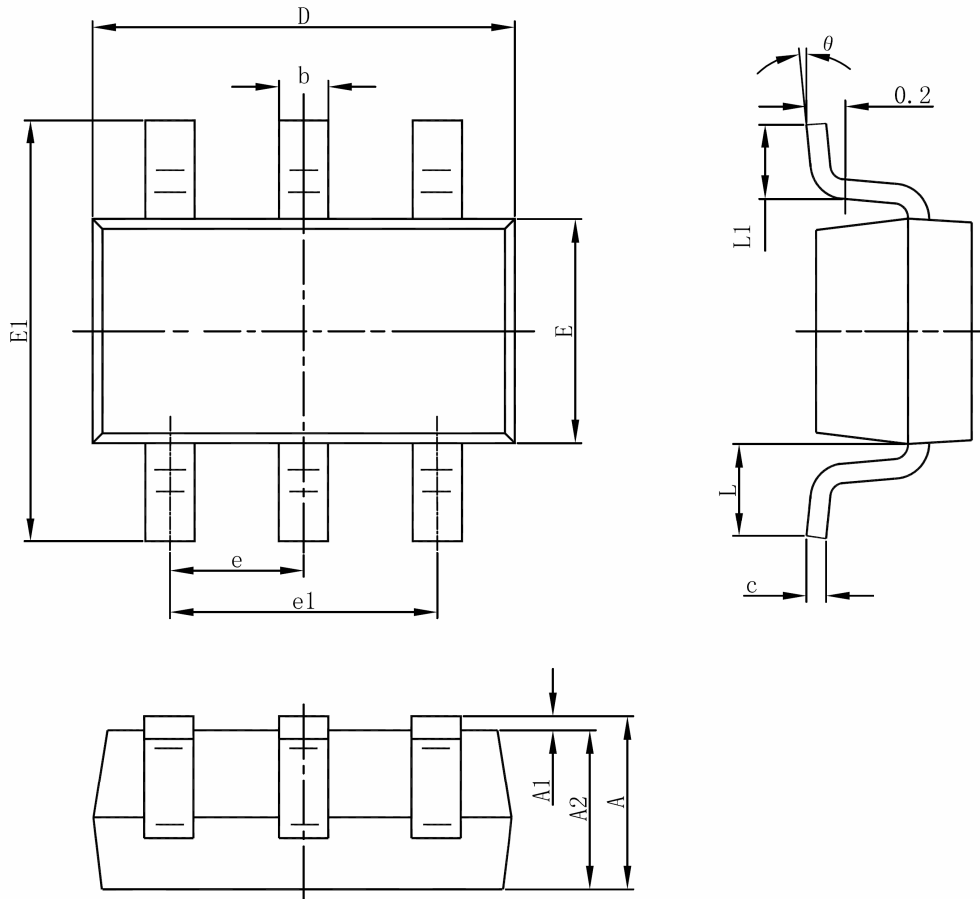

Figure 8: Supply current vs Ambient Temperature



PACKAGE DIMENSION

SOT-23-6



| Symbol | Dimensions In Millimeters | | Dimensions In Inches | |
|--------|---------------------------|-------|----------------------|-------|
| | Min | Max | Min | Max |
| A | 1.050 | 1.250 | 0.041 | 0.049 |
| A1 | 0.000 | 0.100 | 0.000 | 0.004 |
| A2 | 1.050 | 1.150 | 0.041 | 0.045 |
| b | 0.300 | 0.500 | 0.012 | 0.020 |
| c | 0.100 | 0.200 | 0.004 | 0.008 |
| D | 2.820 | 3.020 | 0.111 | 0.119 |
| E | 1.500 | 1.700 | 0.059 | 0.067 |
| E1 | 2.650 | 2.950 | 0.104 | 0.116 |
| e | 0.950TYP | | 0.037TYP | |
| e1 | 1.800 | 2.000 | 0.071 | 0.079 |
| L | 0.600REF | | 0.024REF | |
| L1 | 0.300 | 0.600 | 0.012 | 0.024 |
| θ | 0° | 8° | 0° | 8° |