

FEATURES

4.72 mm × 3.76 mm × 1.0 mm surface mount package
High SNR: 62 dBA
High sensitivity: -37 dBV
Flat frequency response from 100 Hz to over 12 kHz
Low current consumption: <200 μA
Single-ended analog output
High PSRR: >50 dB
Compatible with Sn/Pb and Pb-free solder processes
RoHS/WEEE compliant

APPLICATIONS

Cell phones
PC audio
Digital cameras
Bluetooth headsets

GENERAL DESCRIPTION

The ADMP401-1 is a high quality, low cost, low power analog output bottom-ported omnidirectional MEMS microphone. The ADMP401-1 consists of a MEMS microphone element and an output amplifier. The ADMP401-1 has a high SNR and high sensitivity, making it an excellent choice for far field applications. The ADMP401-1 has a flat wideband frequency response resulting in natural sound with high intelligibility. Low current consumption enables long battery life for portable applications. A built-in particle filter provides for high reliability.

The ADMP401-1 is available in a thin 4.72 mm × 3.76 mm × 1.0 mm surface mount package. The ADMP401-1 is reflow solder compatible with no sensitivity degradation.

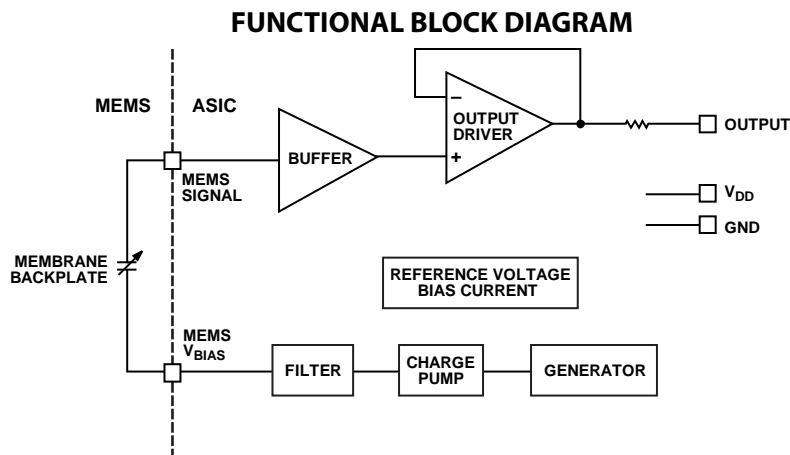

Figure 1.

07712-001

Rev. PrB

Information furnished by Analog Devices is believed to be accurate and reliable. However, no responsibility is assumed by Analog Devices for its use, nor for any infringements of patents or other rights of third parties that may result from its use. Specifications subject to change without notice. No license is granted by implication or otherwise under any patent or patent rights of Analog Devices. Trademarks and registered trademarks are the property of their respective owners.

TABLE OF CONTENTS

Features	1	Typical Performance Characteristics	6
Applications.....	1	Handling Instructions.....	7
General Description	1	Pick-and-Place Equipment	7
Functional Block Diagram	1	Reflow Solder	7
Specifications.....	3	Board Wash	7
Absolute Maximum Ratings.....	4	Outline Dimensions	8
ESD Caution.....	4	Ordering Guide	8
Pin Configuration and Function Descriptions.....	5		

SPECIFICATIONS

$T_A = 25^\circ\text{C}$, $V_{DD} = 1.8\text{ V}$, unless otherwise noted. All minimum and maximum specifications are guaranteed. Typical specifications are not guaranteed.

Table 1.

Parameter	Symbol	Test Conditions/Comments	Min	Typ	Max	Unit
PERFORMANCE						
Directionality				Omni		
Sensitivity		1 kHz, 94 dB SPL	-40	-37	-34	dBV
Signal-to-Noise Ratio	SNR		60	62		dBA
Equivalent Input Noise	EIN			32		dBA SPL
Frequency Response		100 Hz to 10 kHz	-2	0	+2	dB
		100 Hz to 12 kHz	-3	0	+2	dB
Total Harmonic Distortion	THD	105 dB SPL			3	%
Power Supply Rejection Ratio	PSRR	217 Hz, 100 mV p-p square wave superimposed on $V_{DD} = 1.8\text{ V}$	50			dB
Maximum Acoustic Input		Peak		120		dB SPL
POWER SUPPLY						
Supply Voltage	V_{DD}		1.5		3.6	V
Supply Current	I_S				200	μA
OUTPUT CHARACTERISTICS						
Output Impedance	Z_{OUT}			200		Ω
Polarity				Noninverting ¹		

¹ Positive going (increasing) pressure on the membrane results in a positive going (increasing) output voltage.

ABSOLUTE MAXIMUM RATINGS

Table 2.

Parameter	Rating
Supply Voltage	3.6V
Sound Pressure Level (SPL)	160 dB
Mechanical Shock	20,000 g
Vibration	Per MIL-STD-883G
Temperature Range	-40°C to +85°C

Stresses above those listed under Absolute Maximum Ratings may cause permanent damage to the device. This is a stress rating only; functional operation of the device at these or any other conditions above those indicated in the operational section of this specification is not implied. Exposure to absolute maximum rating conditions for extended periods may affect device reliability.

ESD CAUTION



ESD (electrostatic discharge) sensitive device. Charged devices and circuit boards can discharge without detection. Although this product features patented or proprietary protection circuitry, damage may occur on devices subjected to high energy ESD. Therefore, proper ESD precautions should be taken to avoid performance degradation or loss of functionality.

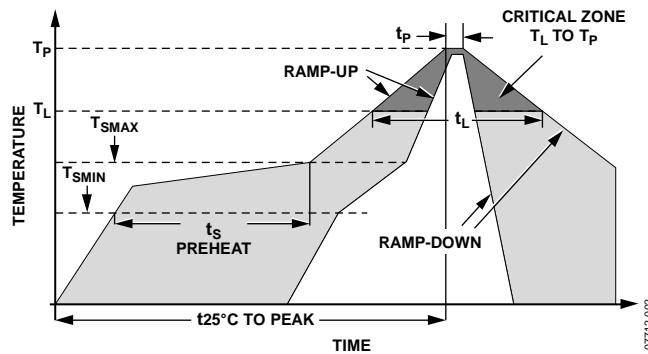
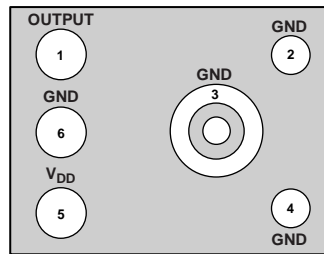

Figure 2. Recommended Soldering Profile

Table 3. Recommended Soldering Profile

Profile Feature	Sn63/Pb37	Pb-Free
Average Ramp Rate (T_L to T_P)	3°C/sec max	3°C/sec max
Preheat		
Minimum Temperature (T_{SMIN})	100°C	150°C
Maximum Temperature (T_{SMAX})	150°C	200°C
Time (T_{SMIN} to T_{SMAX}), t_s	60 sec to 120 sec	60 sec to 120 sec
Ramp-Up Rate (T_{SMAX} to T_L)	3°C/sec	3°C/sec
Time Maintained Above Liquidous (t_L)	60 sec to 150 sec	60 sec to 150 sec
Liquidous Temperature (T_L)	183°C	217°C
Peak Temperature (T_P)	240°C + 0°C/-5°C	260°C + 0°C/-5°C
Time Within 5°C of Actual Peak Temperature (t_p)	10 sec to 30 sec	20 sec to 40 sec
Ramp-Down Rate	6°C/sec max	6°C/sec max
Time 25°C to Peak Temperature	6 minute max	8 minute max

PIN CONFIGURATION AND FUNCTION DESCRIPTIONS



BOTTOM VIEW
(TERMINAL SIDE DOWN)
Not to Scale

007712-003

Figure 3. Pin Configuration (Bottom View)

Table 4. Pin Function Descriptions

Pin No.	Mnemonic	Description
1	OUTPUT	Analog Output Signal.
2	GND	Ground.
3	GND	Ground.
4	GND	Ground.
5	V _{DD}	Power Supply.
6	GND	Ground.

TYPICAL PERFORMANCE CHARACTERISTICS

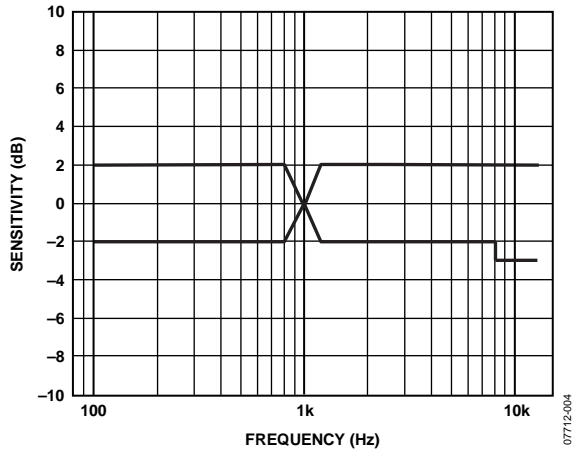

Figure 4. Typical Frequency Response

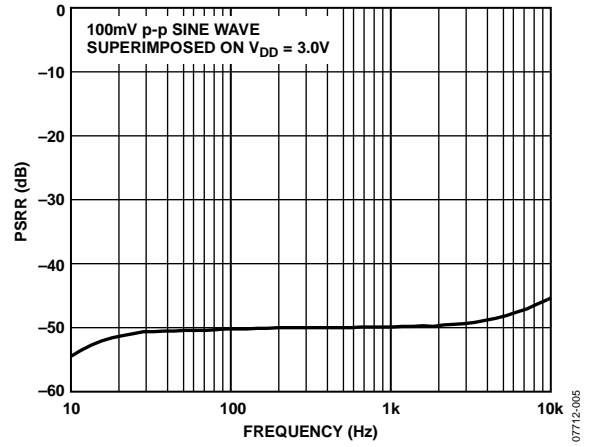

Figure 5. Typical Power Supply Rejection Ratio vs. Frequency

HANDLING INSTRUCTIONS

PICK-AND-PLACE EQUIPMENT

The MEMS microphone can be handled using standard pick-and-place and chip shooting equipment. Care should be taken to avoid damage to the MEMS microphone structure as follows:

- Use a standard pickup tool to handle the microphone. Because the microphone hole is on the bottom of the package, the pickup tool can make contact with any part of the lid surface.
- Use care during pick-and-place to ensure that no high shock events above 20 kg are experienced, because such events may cause damage to the microphone.
- Do not pick up the microphone with a vacuum tool that makes contact with the bottom side of the microphone. Do not pull air out or blow air into the microphone port.
- Do not use excessive force to place the microphone on the PCB.

REFLOW SOLDER

Standard reflow solder conditions specified in Figure 2 can be used to attach the MEMS microphone to the PCB.

BOARD WASH

When washing the PCB, ensure that water does not make contact with the microphone port. Blow-off procedures and ultrasonic cleaning must not be used.

OUTLINE DIMENSIONS

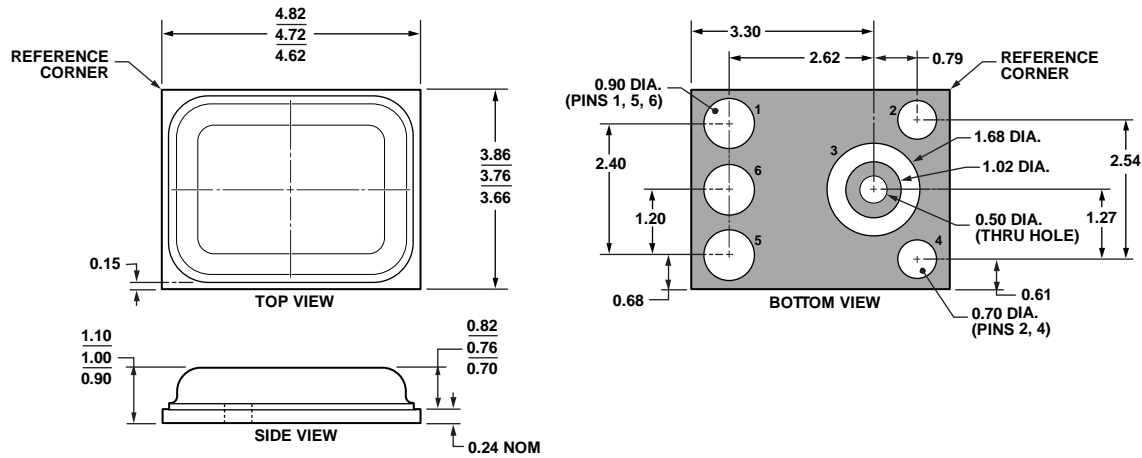
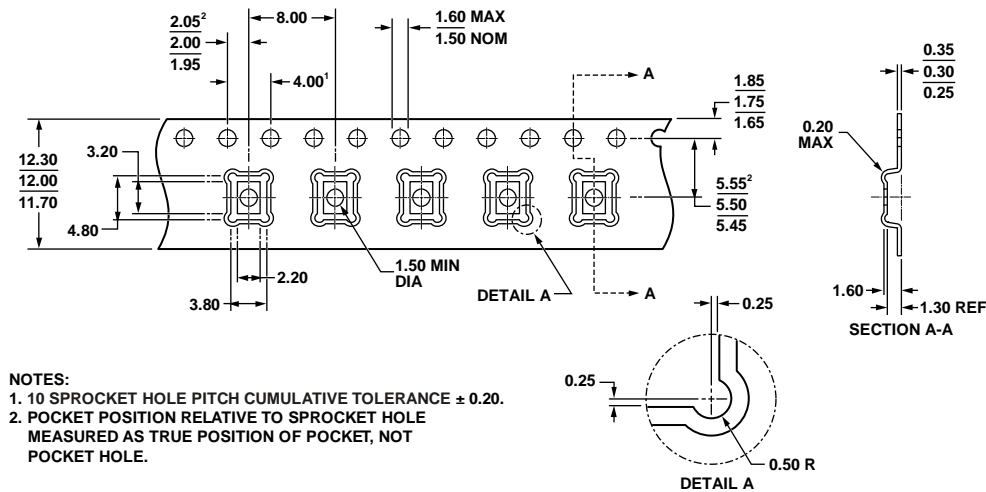

Figure 6. 6-Terminal Chip Array Small Outline No Lead Cavity [LGA_CAV]
4.72 mm x 3.76 mm Body
(CE-6-1)
Dimensions shown in millimeters



NOTES:
1. 10 SPROCKET HOLE PITCH CUMULATIVE TOLERANCE ± 0.20.
2. POCKET POSITION RELATIVE TO SPROCKET HOLE MEASURED AS TRUE POSITION OF POCKET, NOT POCKET HOLE.

Figure 7. LGA_CAV Tape and Reel Outline Dimensions
Dimensions shown in millimeters

ORDERING GUIDE

Model	Temperature Range	Package Description	Package Option	Ordering Quantity
ADMP401-1ACEZ-RL ¹	-40°C to +85°C	6-Terminal LGA_CAV, 13" Tape and Reel	CE-6-1	4,000
ADMP401-1ACEZ-RL7 ¹	-40°C to +85°C	6-Terminal LGA_CAV, 7" Tape and Reel	CE-6-1	1,000

¹ Z = RoHS Compliant Part.