

Silicon NPN Power Transistors

2SC4940

DESCRIPTION

- With ITO-220 package
- Switching power transistor

PINNING

PIN	DESCRIPTION
1	Base
2	Collector
3	Emitter

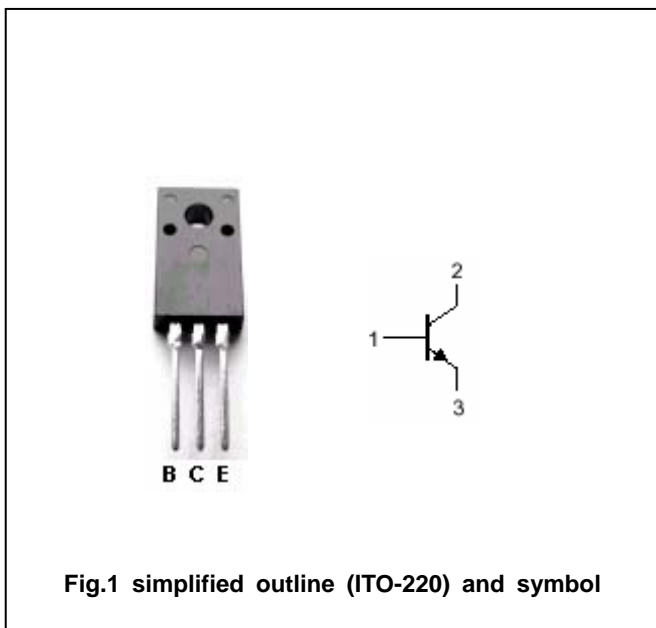

Absolute maximum ratings(Ta=25)

SYMBOL	PARAMETER	CONDITIONS	VALUE	UNIT
V _{CBO}	Collector-base voltage	Open emitter	1200	V
V _{CEO}	Collector-emitter voltage	Open base	550	V
V _{EBO}	Emitter-base voltage	Open collector	7	V
I _C	Collector current		4	A
I _{CM}	Collector current-Peak		8	A
I _B	Base current		2	A
I _{BM}	Base current-peak		4	A
P _T	Total power dissipation	T _C =25	30	W
T _j	Junction temperature		150	
T _{stg}	Storage temperature		-55~150	

THERMAL CHARACTERISTICS

SYMBOL	PARAMETER	MAX	UNIT
R _{th j-c}	Thermal resistance junction case	4.16	/W

Silicon NPN Power Transistors

2SC4940

CHARACTERISTICS

T_j=25 unless otherwise specified

SYMBOL	PARAMETER	CONDITIONS	MIN	TYP.	MAX	UNIT
V _{CEO(SUS)}	Collector-emitter sustaining voltage	I _C =0.1A ; I _B =0	550			V
V _{CEsat}	Collector-emitter saturation voltage	I _C =2A ; I _B =0.4A			1.0	V
V _{BEsat}	Base-emitter saturation voltage	I _C =2A ; I _B =0.4A			1.5	V
I _{CBO}	Collector cut-off current	At rated volatge			0.1	mA
I _{CEO}	Collector cut-off current					
I _{EBO}	Emitter cut-off current	At rated volatge			0.1	mA
h _{FE-1}	DC current gain	I _C =2A ; V _{CE} =5V	10			
h _{FE-2}	DC current gain	I _C =1mA ; V _{CE} =5V	10			
f _T	Transition frequency	I _C =0.4A ; V _{CE} =10V		10		MHz
Switching times						
t _{on}	Turn-on time	I _C =2A; I _{B1} =0.4A I _{B2} =0.8A , R _L =75 V _{BB2} =4V			0.8	μs
t _s	Storage time				3.0	μs
t _f	Fall time				0.3	μs

Silicon NPN Power Transistors

2SC4940

PACKAGE OUTLINE

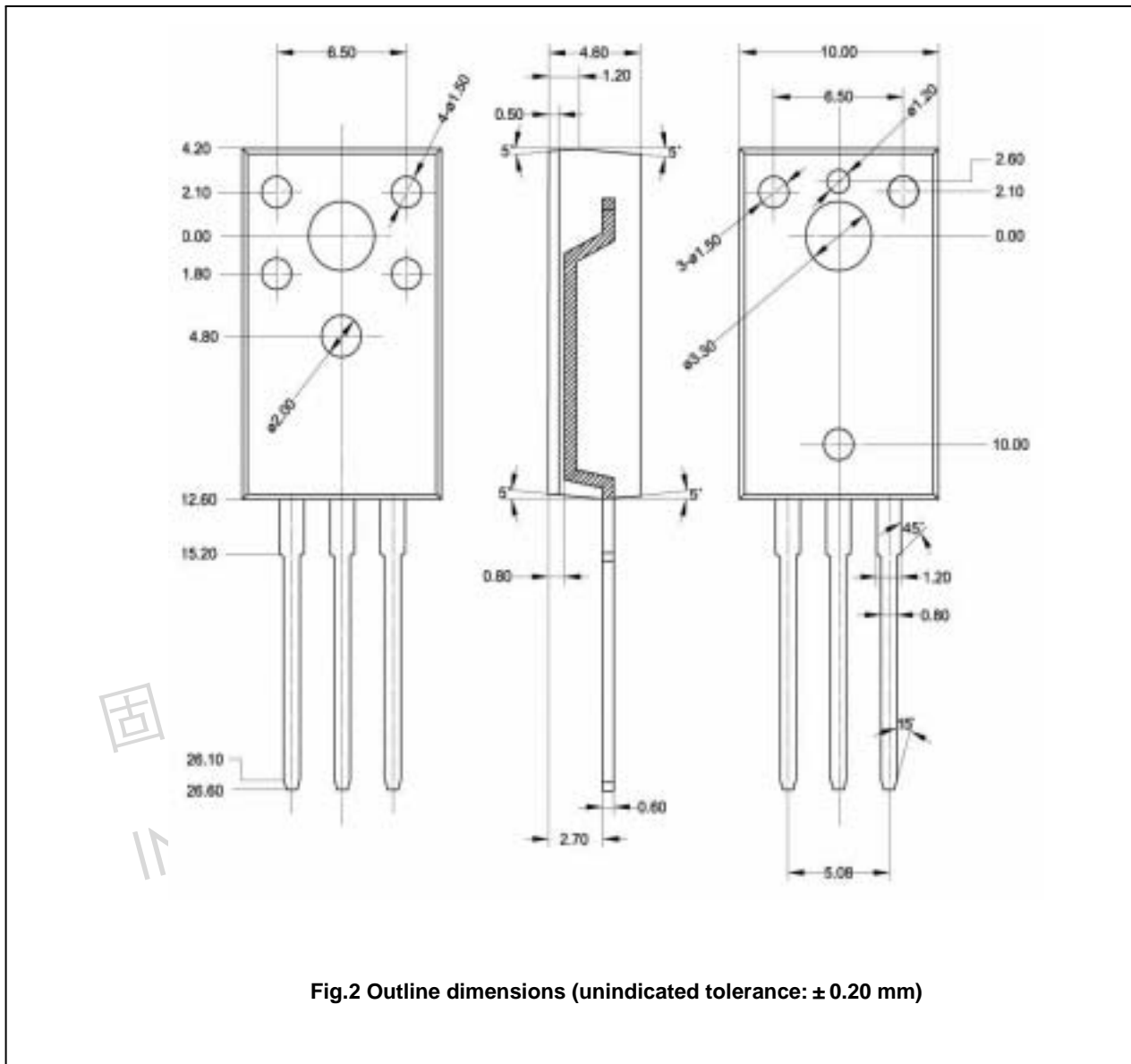

Fig.2 Outline dimensions (unindicated tolerance: ± 0.20 mm)