

**Silicon PNP Power Transistors**

**2SA794 2SA794A**

**DESCRIPTION**

- With TO-126 package
- Complement to type 2SC1567/1567A
- High collector-emitter voltage  $V_{CEO}$

**APPLICATIONS**

- For low frequency output driver
- Optimum for the driver stage of low frequency and 40W to 100W output amplifier

**PINNING**

PIN	DESCRIPTION
1	Emitter
2	Collector;connected to mounting base
3	Base

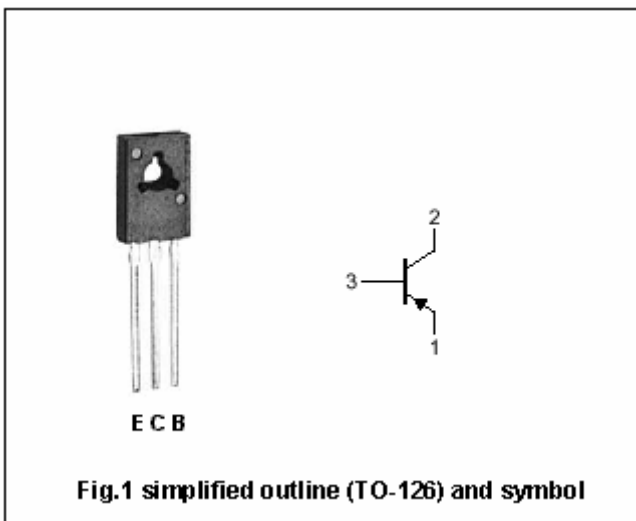

**Absolute maximum ratings(Ta=25°C)**

SYMBOL	PARAMETER	CONDITIONS	VALUE	UNIT
$V_{CBO}$	Collector-base voltage	2SA794	-100	V
		2SA794A	-120	
$V_{CEO}$	Collector- emitter voltage	2SA794	-100	V
		2SA794A	-120	
$V_{EBO}$	Emitter-base voltage	Open collector	-5	V
$I_C$	Collector current		-0.5	A
$I_{CM}$	Collector current-peak		-1	A
$P_C$	Collector power dissipation	$T_C=25^{\circ}C$	1.2*	W
$T_j$	Junction temperature		150	°C
$T_{stg}$	Storage temperature		-55~+150	°C

\*Without heat sink

## Silicon PNP Power Transistors

## 2SA794 2SA794A

## CHARACTERISTICS

T<sub>j</sub>=25°C unless otherwise specified

SYMBOL	PARAMETER		CONDITIONS	MIN	TYP.	MAX	UNIT
V <sub>(BR)CEO</sub>	Collector-emitter breakdown voltage	2SA794	I <sub>C</sub> =-100 μ A ; I <sub>B</sub> =0	-100			V
		2SA794A		-120			
V <sub>(BR)EBO</sub>	Emitter-base breakdown voltage		I <sub>E</sub> =-1 μ A ; I <sub>C</sub> =0	-5			V
V <sub>CEsat</sub>	Collector-emitter saturation voltage		I <sub>C</sub> =-500mA ; I <sub>B</sub> =-50mA		-0.2	-0.4	V
V <sub>BEsat</sub>	Base-emitter saturation voltage		I <sub>C</sub> =-500mA ; I <sub>B</sub> =-50mA		-0.85	-1.2	V
h <sub>FE-1</sub>	DC current gain		I <sub>C</sub> =-150mA ; V <sub>CE</sub> =-10V	90		220	
h <sub>FE-2</sub>	DC current gain		I <sub>C</sub> =-500mA ; V <sub>CE</sub> =-5V	50			
C <sub>OB</sub>	Collector output capacitance		I <sub>E</sub> =0 ; V <sub>CB</sub> =-10V;f=1MHz		20		pF
f <sub>T</sub>	Transition frequency		V <sub>CB</sub> =-10V;I <sub>E</sub> =50mA;f=200MHz		120		MHz

◆ h<sub>FE-1</sub> Classifications

Q	R
90-155	130-220

Silicon PNP Power Transistors

2SA794 2SA794A

PACKAGE OUTLINE

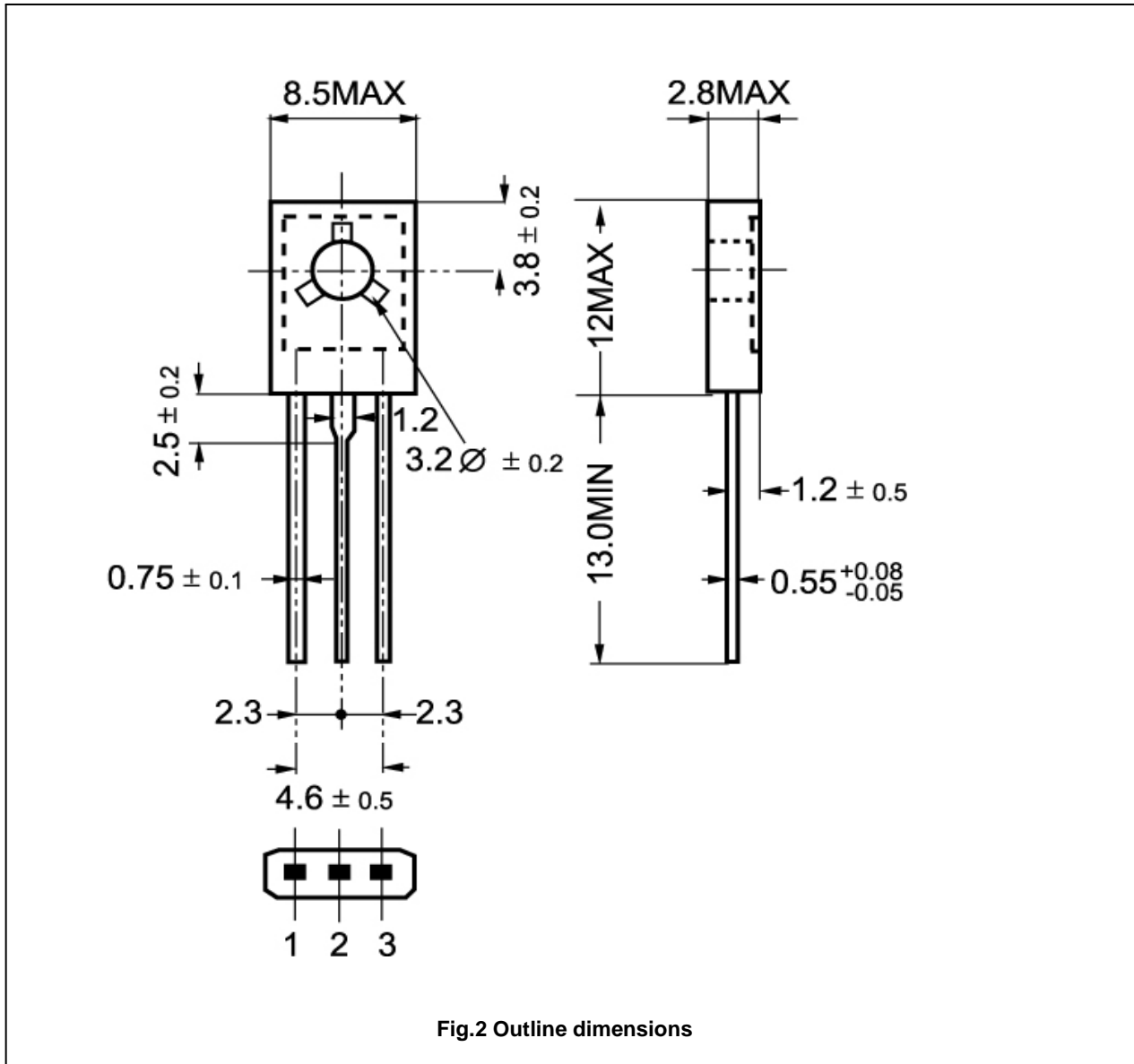

Fig.2 Outline dimensions