

81 x 128 single-chip LCD controller/driver

Features

- 104 x 128 bits Display Data RAM
- Programmable MUX rate
- Programmable frame rate
- X,Y Programmable carriage return
- Dual partial display mode
- Row by Row Scrolling
- Automatic data RAM Blanking procedure
- Selectable Input interface:
 - I²C Bus Fast and Hs-mode (read and write)
 - Parallel Interface (read and write)
 - Serial Interface (read and write)
- Fully Integrated oscillator requires no external components
- CMOS compatible inputs
- Fully integrated configurable LCD bias voltage generator with:
 - Selectable multiplication factor (up to 6x)
 - Effective sensing for High Precision Output
- Eight selectable temperature compensation coefficients
- Designed for chip-on-glass (COG) applications
- Low power consumption, suitable for battery operated systems
- Logic supply voltage range from 1.7 to 3.6V
- High voltage generator supply voltage range from 1.75 to 4.2V
- Display supply voltage range from 4.5 V to 14.5V
- Backward compatibility with STE2001

Description

The STE2002 is a low power CMOS LCD controller driver. Designed to drive a 81 rows by 128 columns graphic display, provides all necessary functions in a single chip, including on-chip LCD supply and bias voltages generators, resulting in a minimum of external components and in a very low power consumption. The STE2002 features three standard interfaces (Serial, Parallel & I²C) for ease of interfacing with the host microcontroller.

Block diagram

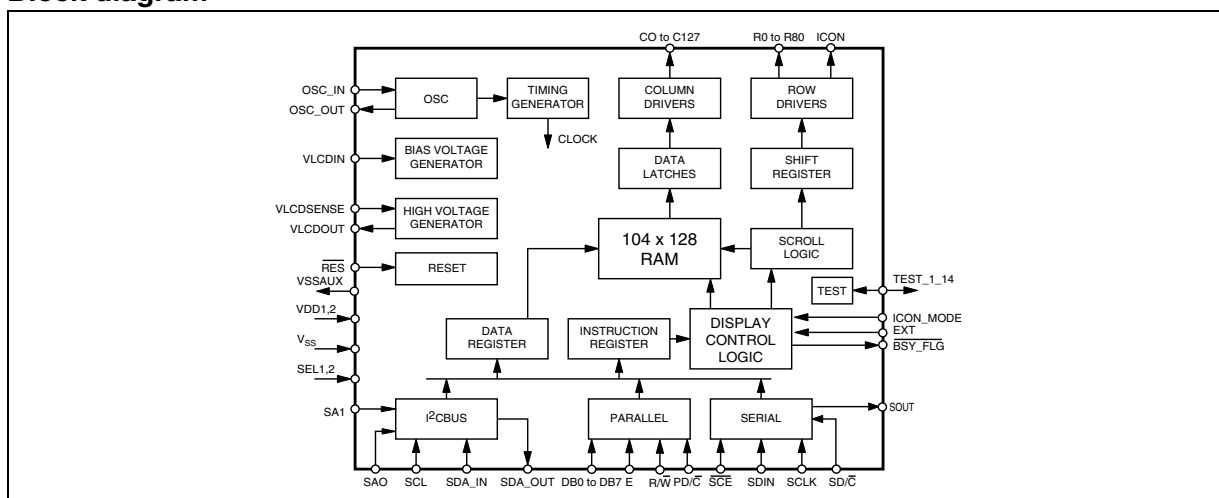

Contents

- 1 Pin description 4**
- 2 Circuit description 8**
 - 2.1 Supplies voltages and grounds 8
 - 2.2 Internal supply voltage generator 8
 - 2.3 Oscillator 8
 - 2.4 Bias levels 8
 - 2.5 LCD voltage generation 10
 - 2.6 Temperature coefficient 11
- 3 Display data RAM 12**
- 4 Instruction set 21**
 - 4.1 Reset (RES) 21
 - 4.2 Power down (PD = 1) 21
 - 4.3 Memory blanking procedure 22
 - 4.4 Checker board procedure 22
 - 4.5 Scrolling function 22
 - 4.6 Dual partial display 23
- 5 Bus interfaces 24**
 - 5.1 I2C interface 24
 - 5.1.1 Communication protocol 26
 - 5.2 Serial interface 27
 - 5.3 Parallel interface 29
- 6 Electrical characteristics 44**
 - 6.1 Absolute maximum ratings 44
 - 6.2 DC operation 45
 - 6.3 AC operation 47
- 7 Pad coordinates 51**

8	Mechanical data	58
9	Ordering information	60
10	Revision history	60

1 Pin description

Table 1. Pin description

N°	Pad	Type	Function						
R0 to R80	129-169 282-322	O	LCD Row Driver Output						
ICON	323	O	ICON Row Driver						
C0 to C127	1-128	O	LCD Column Driver Output						
V _{SS}	236-255	GND	Ground pads.						
V _{DD1}	188-199	Supply	IC Positive Power Supply						
V _{DD2}	200-211	Supply	Internal Generator Supply Voltages.						
V _{LCDIN}	261-270	Supply	LCD Supply Voltages for the Column and Row Output Drivers.						
V _{LCDOUT}	273-282	Supply	Voltage Multiplier Output						
V _{LCDSENSE}	271-272	Supply	Voltage Multiplier Regulation Input. V _{LCDOUT} Sensing for Output Voltage Fine Tuning						
V _{SSAUX}	180, 231, 218	O	Ground Reference for Selection Pins Configuration						
SEL1,2	184,185	I	Interface Mode Selection						
EXT	183	I	Extended Instruction Set Selection <table border="1" style="margin-left: auto; margin-right: auto;"> <thead> <tr> <th>Ext pad config</th> <th>Instruction set selected</th> </tr> </thead> <tbody> <tr> <td>VSS or VSSAUX</td> <td>BASIC</td> </tr> <tr> <td>VDD1</td> <td>EXTENDED</td> </tr> </tbody> </table>	Ext pad config	Instruction set selected	VSS or VSSAUX	BASIC	VDD1	EXTENDED
Ext pad config	Instruction set selected								
VSS or VSSAUX	BASIC								
VDD1	EXTENDED								
ICON_MODE	186	I	ICON ROW Management <table border="1" style="margin-left: auto; margin-right: auto;"> <thead> <tr> <th>Icon mode pad config</th> <th>Icon mode status</th> </tr> </thead> <tbody> <tr> <td>VSS or VSSAUX</td> <td>DISABLED</td> </tr> <tr> <td>VDD1</td> <td>ENABLED</td> </tr> </tbody> </table>	Icon mode pad config	Icon mode status	VSS or VSSAUX	DISABLED	VDD1	ENABLED
Icon mode pad config	Icon mode status								
VSS or VSSAUX	DISABLED								
VDD1	ENABLED								
SDA_IN	234	I	I ² C Bus Data In						
SDA_OUT	232	O	I ² C Bus Data Out						
SCL	235	I	I ² C bus Clock						
SA0	182	I	I ² C Slave Address BIT 0						
SA1	181	I	I ² C Slave Address BIT 1						
OSCIN	187	I	External Oscillator Input						
OSCOU	260	O	Internal/External Oscillator Out						
RES	230	I	Reset Input. Active Low.						
DB0 to DB7	220-227	I/O	Parallel Interface 8 Bit Data Bus						

Table 1. Pin description (continued)

N°	Pad	Type	Function								
R/W	219	I	Parallel Interface Read & Write Control Line								
E	229	I	Parallel Interface Data Latch Signal.								
PD/C	228	I	Parallel Interface Data/Command Selector								
SDIN	214	I	Serial Interface Data Input								
SCLK	217	I	Serial Interface Clock								
SCE	216	I	Serial Interface ENABLE. When Low the Incoming Data are Clocked In.								
SD/C	215	I	Serial Interface Data/Command Selector								
SOUT	213	O	Serial Out								
BSYFLG	212	O	Active Procedure Flag. Notice if There is an ongoing Internal Operation or an active reset. Active Low.								
T1 to T14	170-179, 256-259	I/O	<p>Test Pads. - A 50kohm pull-down resistor is added on input pis.</p> <table border="1"> <thead> <tr> <th>Test Num.</th> <th>Pin Configuration</th> </tr> </thead> <tbody> <tr> <td>TEST_1 TEST_2 TEST_3 TEST_4</td> <td>OPEN</td> </tr> <tr> <td>TEST_5 TEST_6 TEST_7 TEST_8 TEST_9 TEST_10</td> <td>VSS / VSSAUX</td> </tr> <tr> <td>TEST_11 TEST_12 TEST_13 TEST_14</td> <td>VSS / VSSAUX</td> </tr> </tbody> </table>	Test Num.	Pin Configuration	TEST_1 TEST_2 TEST_3 TEST_4	OPEN	TEST_5 TEST_6 TEST_7 TEST_8 TEST_9 TEST_10	VSS / VSSAUX	TEST_11 TEST_12 TEST_13 TEST_14	VSS / VSSAUX
Test Num.	Pin Configuration										
TEST_1 TEST_2 TEST_3 TEST_4	OPEN										
TEST_5 TEST_6 TEST_7 TEST_8 TEST_9 TEST_10	VSS / VSSAUX										
TEST_11 TEST_12 TEST_13 TEST_14	VSS / VSSAUX										

Figure 1. Chip mechanical drawing

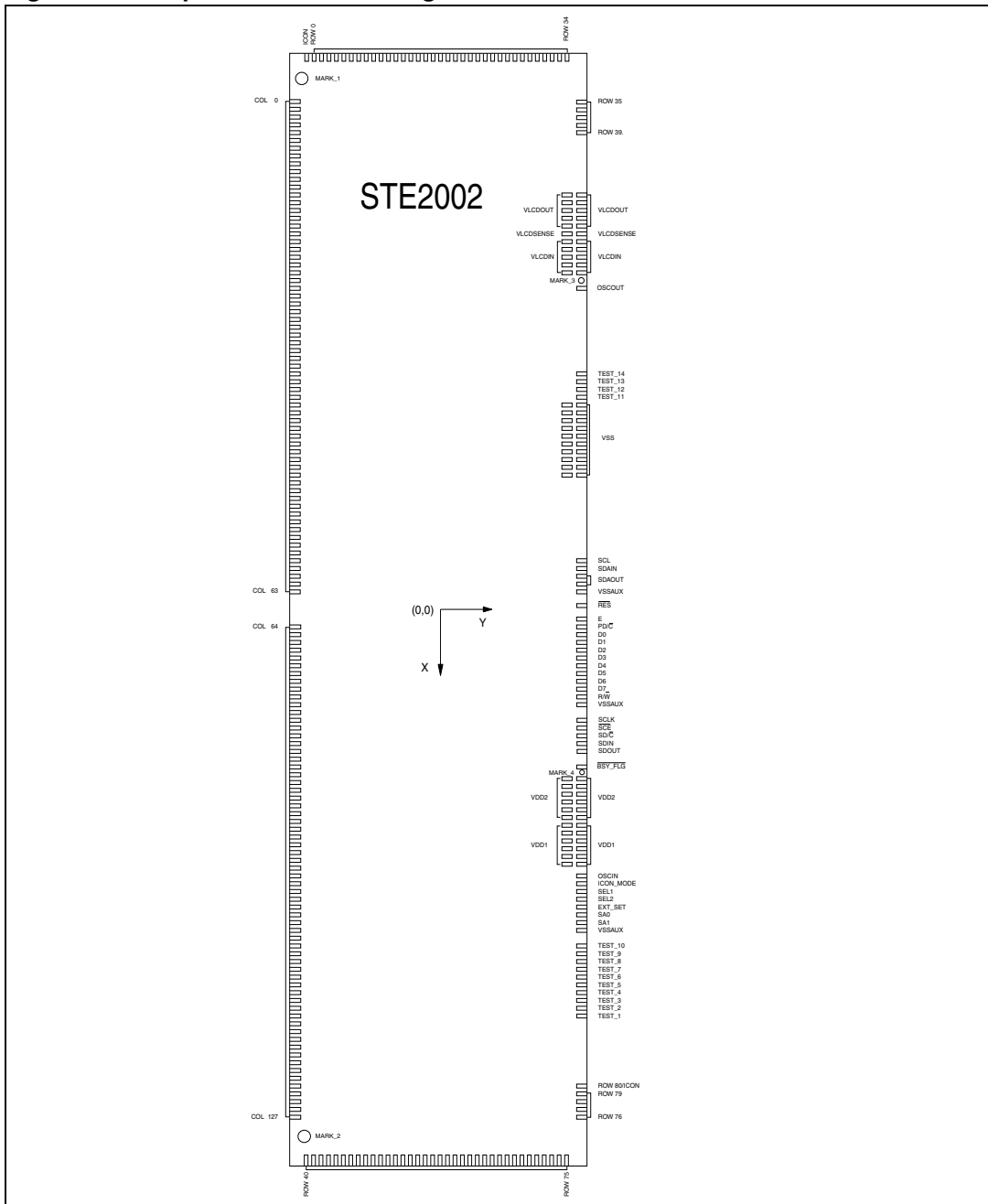
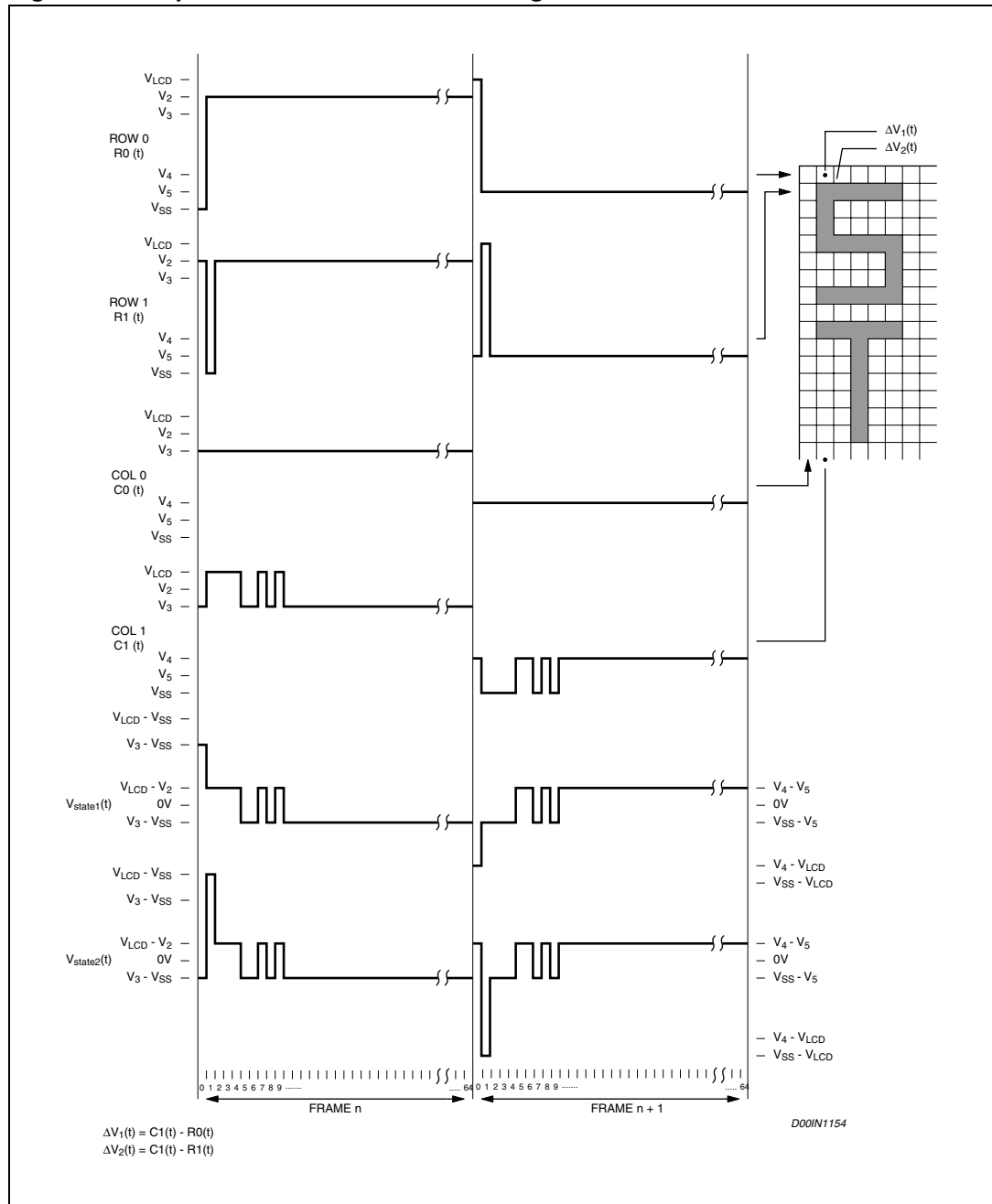

Figure 2. Improved ALTH & PLESKO driving method



2 Circuit description

2.1 Supplies voltages and grounds

V_{DD2} is supply voltages to the internal voltage generator (see below). If the internal voltage generator is not used, this should be connected to V_{DD1} pad. V_{DD1} supplies the rest of the IC. V_{DD1} supply voltage could be different form V_{DD2} .

2.2 Internal supply voltage generator

The IC has a fully integrated (no external capacitors required) charge pump for the Liquid Crystal Display supply voltage generation. The multiplying factor can be programmed to be: Auto, X6, X5, X4, X3, X2, using the 'set CP Multiplication' Command. If Auto is set, the multiplying factor is automatically selected to have the lowest current consumption in every condition. This make possible to have an input voltage that changes over time and a constant V_{LCD} voltage. The output voltage (V_{LCDOUT}) is tightly controlled through the $V_{LCDSENSE}$ pad. For this voltage, eight different temperature coefficients (TC, rate of change with temperature) can be programmed using the bits TC1 and TC0 and T2, T1 & T0. This will ensure no contrast degradation over the LCD operating range. Using the internal charge pump, the V_{LCDIN} and V_{LCDOUT} pads must be connected together. An external supply could be connected to V_{LCDIN} to supply the LCD without using the internal generator. In such event the V_{LDCOUT} and $V_{LCDSENSE}$ must be connected to GND and the internal voltage generator must be programmed to zero (PRS = [0;0], Vop = 0 - Reset condition).

2.3 Oscillator

A fully integrated oscillator (requires no external components) is present to provide the clock for the Display System. When used the OSC pad must be connected to V_{DD1} pad. An external oscillator could be used and fed into the OSC pin. An oscillator out is provided on the OSCOUT Pad to cascade two or more drivers

2.4 Bias levels

To properly drive the LCD, six (Including VLCD and VSS) different voltage (Bias) levels are generated. The ratios among these levels and VLCD, should be selected according to the MUX ratio (m). They are established to be (Fig. 4):

$$V_{LCD}, \frac{n+3}{n+4} V_{LCD}, \frac{n+2}{n+4} V_{LCD}, \frac{2}{n+4} V_{LCD}, \frac{1}{n+4} V_{LCD}, V_{SS}$$

Figure 3. Bias level generator

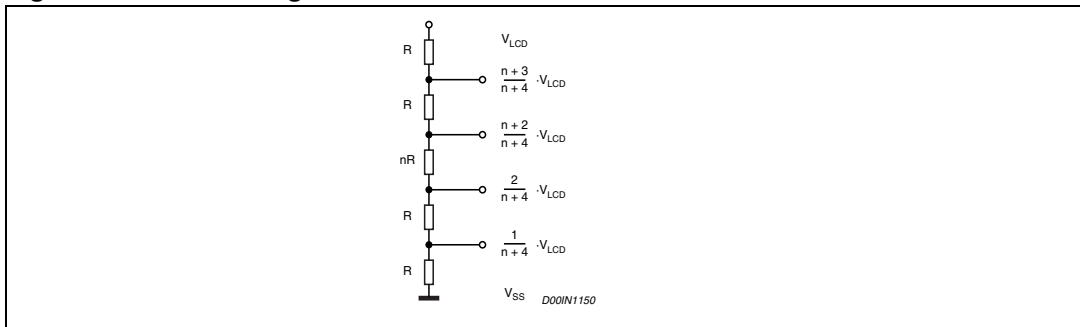

thus providing an $1/(n+4)$ ratio, with n calculated from:

$$= \sqrt{m} -$$

For $m = 81$, $n = 6$ and an $1/10$ ratio is set.

For $m = 65$, $n = 5$ and an $1/9$ ratio is set.

The STE2002 provides three bits (BS0, BS1, BS2) for programming the desired Bias Ratio as shown below:

Table 2. Bias ratio programming

BS2	BS1	BS0	n
0	0	0	7
0	0	1	6
0	1	0	5
0	1	1	4
1	0	0	3
1	0	1	2
1	1	0	1
1	1	1	0

The following table Bias Level for $m = 65$ and $m = 81$ are provided:

Table 3. Bias level

Symbol	$m = 65 (1/9)$	$m = 81 (1/10)$
V1	V_{LCD}	V_{LCD}
V2	$8/9 * V_{LCD}$	$9/10 * V_{LCD}$
V3	$7/9 * V_{LCD}$	$8/10 * V_{LCD}$
V4	$2/9 * V_{LCD}$	$2/10 * V_{LCD}$
V5	$1/9 * V_{LCD}$	$1/10 * V_{LCD}$
V6	V_{SS}	V_{SS}

2.5 LCD voltage generation

The LCD Voltage at reference temperature ($T_0 = 27^\circ\text{C}$) can be set using the VOP register content according to the following formula:

$$V_{\text{LCD}}(T=T_0) = V_{\text{LCD}0} = (A_i + V_{\text{OP}} \cdot B) \quad (i=0,1,2)$$

with the following values:

Table 4. LCD voltage values

Symbol	Value	Unit	Note
A ₀	2.95	V	PRS = [0;0]
A ₁	6.83	V	PRS = [0;1]
A ₂	10.71	V	PRS = [1;0]
B	0.0303	V	
T ₀	27	°C	

Note that the three PRS values produce three adjacent ranges for VLCD. If the V_{OP} register and PRS bits are set to zero the internal voltage generator is switched off.

The proper value for the VLCD is a function of the Liquid Crystal Threshold Voltage (V_{th}) and of the Multiplexing Rate. A general expression for this is:

$$V_{\text{LCD}} = \frac{1 + \sqrt{m}}{\sqrt{2 \cdot \left(1 - \frac{1}{\sqrt{m}}\right)}} \cdot V_{\text{th}}$$

For MUX Rate $m = 65$ the ideal V_{LCD} is:

$$V_{\text{LCD}(t_0)} = 6.85 \cdot V_{\text{th}}$$

then:

$$V_{\text{op}} = \frac{(6.85 \cdot V_{\text{th}} - A_i)}{0.03}$$

2.6 Temperature coefficient

As the viscosity, and therefore the contrast, of the LCD are subject to change with temperature, there's the need to vary the LCD Voltage with temperature. The STE2002 provides the possibility to change the VLCD in a linear fashion against temperature with eight different Temperature Coefficient selectable through the T2, T1 and T0 bits. Only four of them are available with basic instruction set (TC1 & TC0 Bits).

Table 5. Temperature coefficients

Name	TC1	TC0	Value	Unit
TC0	0	0	$-0.0 \cdot 10^{-3}$	1/°C
TC2	0	1	$-0.7 \cdot 10^{-3}$	1/°C
TC3	1	0	$-1.05 \cdot 10^{-3}$	1/°C
TC6	1	1	$-2.1 \cdot 10^{-3}$	1/°C

Table 6. Temperature coefficients

Name	TC2	TC1	TC0	Value	Unit
TC0	0	0	0	$-0.0 \cdot 10^{-3}$	1/°C
TC1	0	0	1	$-0.35 \cdot 10^{-3}$	1/°C
TC2	0	1	0	$-0.7 \cdot 10^{-3}$	1/°C
TC3	0	1	1	$-1.05 \cdot 10^{-3}$	1/°C
TC4	1	0	0	$-1.4 \cdot 10^{-3}$	1/°C
TC5	1	0	1	$-1.75 \cdot 10^{-3}$	1/°C
TC6	1	1	0	$-2.1 \cdot 10^{-3}$	1/°C
TC7	1	1	1	$-2.3 \cdot 10^{-3}$	1/°C

Figure 4. LCD voltage

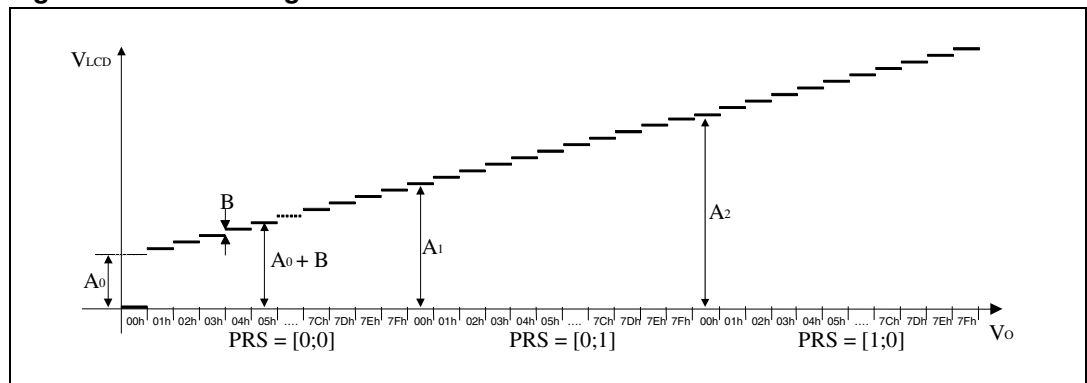

Finally, the V_{LCD} voltage at a given (T) temperature can be calculated as:

$$V_{LCD}(T) = V_{LCD0} \cdot [1 + (T-T_0) \cdot TC]$$

3 Display data RAM

The STE2002, provides an 104X128 bits Static RAM to store Display data. This is organized into 13 (Bank0 to Bank12) banks with 128 Bytes. One of these banks (128 bits wide) can be used for Icons. RAM access is accomplished in either one of the Bus Interfaces provided (see below). Allowed addresses are X0 to X127 (Horizontal) and Y0 to Y12 (Vertical).

When writing to RAM, four addressing mode are provided:

- Normal Horizontal (MX=0 and V=0), having the column with address X= 0 located on the left of the memory map. The X pointer is increased after each byte written. After the last column address (X=X-Carriage), Y address pointer is set to jump to the following bank and X restarts from X=0. (Fig. 6)
- Normal Vertical (MX=0 and V=1), having the column with address X= 0 located on the left of the memory map. The Y pointer is increased after each byte written. After the last Y bank address (Y=Y-Carriage), X address pointer is set to jump to next column and Y restarts from Y=0 (Fig. 7).
- Mirrored Horizontal (MX=1 and V=0), having the column with address X= 0 located on the right of the memory map. The X pointer is increased after each byte written. After the last column address (X=X-Carriage), Y address pointer is set to jump to the next bank and X restarts from X=0 (fig. 8).
- Mirrored Vertical (MX=1 and V=1), having the column with address X= 0 located on the right of the memory map. The Y pointer is increased after each byte written. After the last Y bank address (Y=Y-Carriage), the X pointer is set to jump to next column and Y restarts from Y=0 (fig. 9).

After the last allowed address (X;Y)=(X-Carriage; Y-Carriage), the address pointers always jump to the cell with address (X;Y) = (0;0) (Fi. 10, 11, 12 & 13).

Data bytes in the memory could have the MSB either on top (D0 = 0, Fig.14) or on the bottom (D0=1, Fig. 15).

The STE2002 provides also means to alter the normal output addressing. A mirroring of the Display along the X axis is enabled setting to a logic one MY bit. This function doesn't affect the content of the memory RAM. It is only related to the visualization process.

When ICON MODE=1 the Icon Row is not mirrored with MY and is not scrolled. When ICON Mode=0 the Icon Row is like the other graphic lines and is mirrored and scrolled.

Four are the multiplex ratio available when the partial display mode is disabled (MUX 33, MUX 49, MUX 65 and MUX 81).

Only a subset of writable rows are output on Row drivers.

When **Y-Carriage**<**MUX/8**, if Mux 65 is selected only the first 65 memory rows are visualized, if Mux 49 is selected only the first 49 memory rows are visualized, if Mux 33 is selected only the first 33 memory rows are visualized. All unused Row and Column drivers must be left floating.

When **Y-Carriage**<**MUX/8**, the icon Bank is located to BANK 10 in MUX 81 Mode, to BANK8 in MUX 65 Mode, to BANK 6 in MUX 49 Mode and to BANK 4 in MUX 33 Mode.

When **Y-Carriage**>**MUX/8** lines only 33, 49, 65 or 81 lines are visualized but it is possible to select which lines of DDRAM are connected on the output drivers. The DDRAM rows to visualized can be selected in the 0-Y-Carriage*8 range using the scrolling function.

When **Y-Carriage>MUX lines**, the icon row is moved in DDRAM to the first row of the Y-CARRIAGE Return BANK even if it is always connected on the same output Driver.

When **MY=0**, the icon Row is output on R80 in mux 81 mode, on R72 in MUX 65, on R64 in MUX49 and on R56 in MUX 33.

When **MY=1**, and **ICON MODE=1**, the icon Row is output on R80 in mux 81 mode, on R72 in MUX 65, on R64 in MUX49 and on R56 in MUX 33.

When **MY=1**, and **ICON MODE=0**, the icon Row is output on R0 whatever is the MUX Rate.

When **ICON MODE =1**, the Memory ICON Row content is output on ICON Pad.

If Not Used ICON Pad must be left floating.

Figure 5. Automatic data RAM writing sequence with V=0 and Data RAM Normal Format (MX=0)^(a)

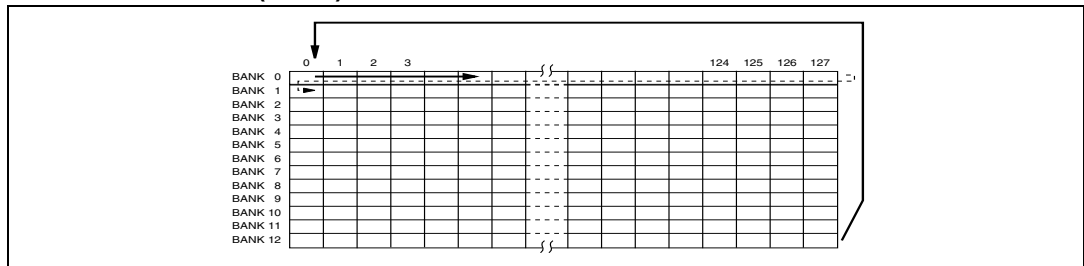

Figure 6. Automatic data RAM writing sequence with V=1 and Data RAM Normal Format (MX=0)^(a)

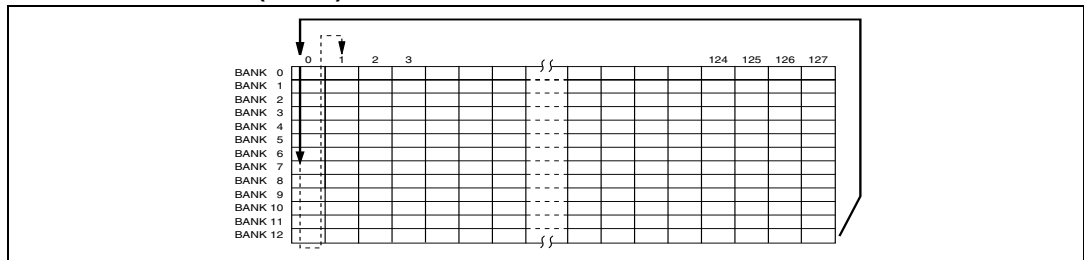
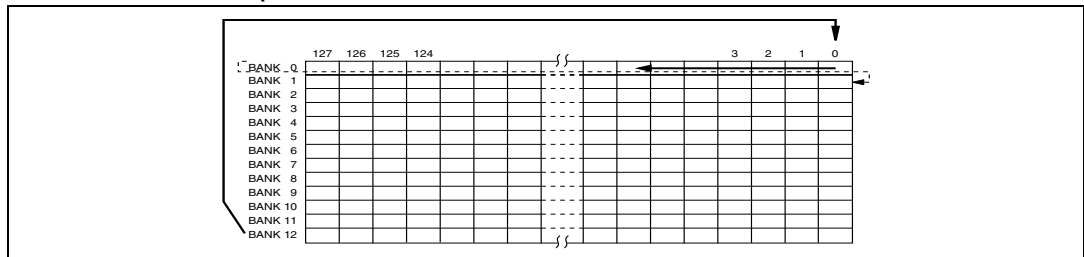

Figure 7. Automatic data RAM writing sequence with V=0 and Data RAM Mirrored Format (MX=1)^(a)



a. X Carriage=127; Y-Carriage = 12

Figure 8. Automatic data RAM writing sequence with V=1 and Data RAM mirrored format (MX=1)^(a)

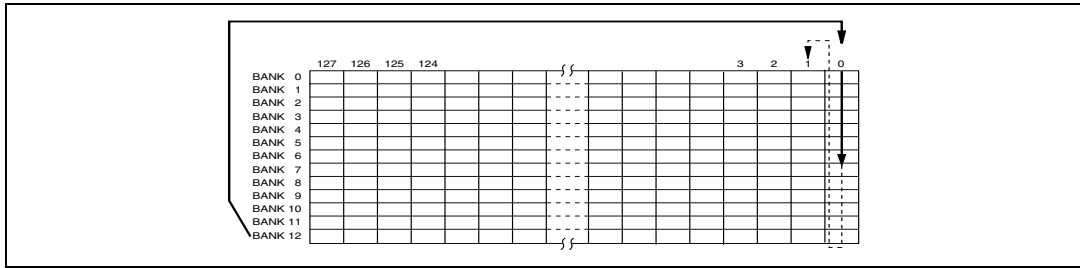

Figure 9. Automatic data RAM writing sequence with X-Y carriage return (V=0; MX=0)

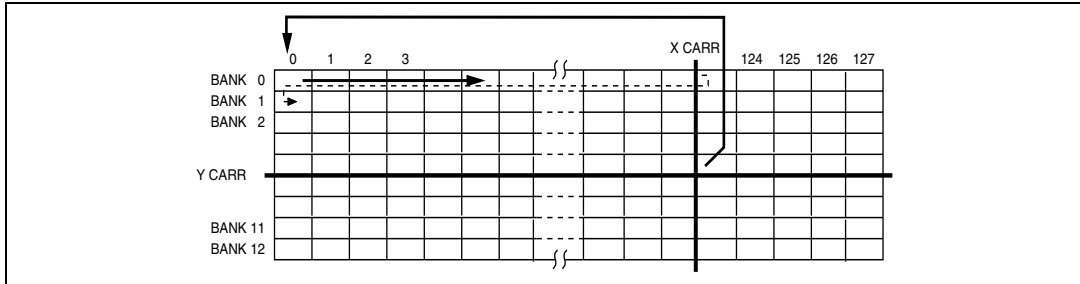

Figure 10. Automatic data RAM writing sequence with X-Y carriage return (V=1; MX=0)

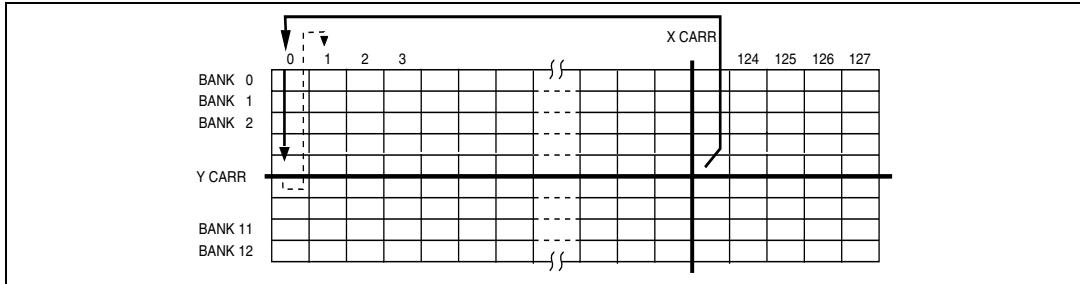

Figure 11. Automatic data RAM writing sequence with X-Y carriage return (V=0; MX=1)

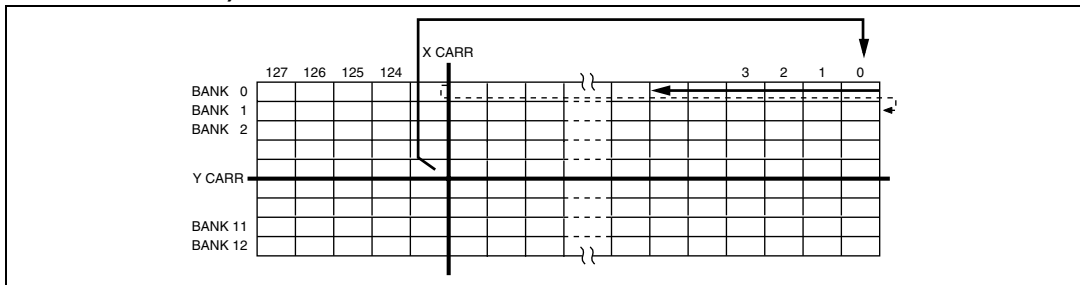

Figure 12. Automatic data RAM writing sequence with X-Y carriage return (V=1; MX=1)

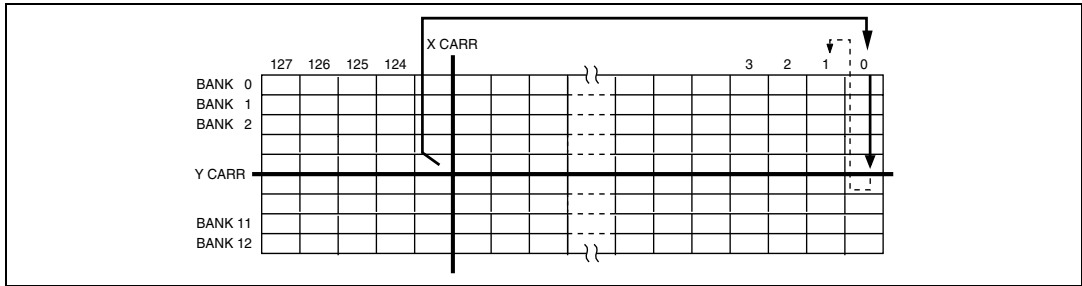

Figure 13. Data RAM Byte organization with D0 = 0

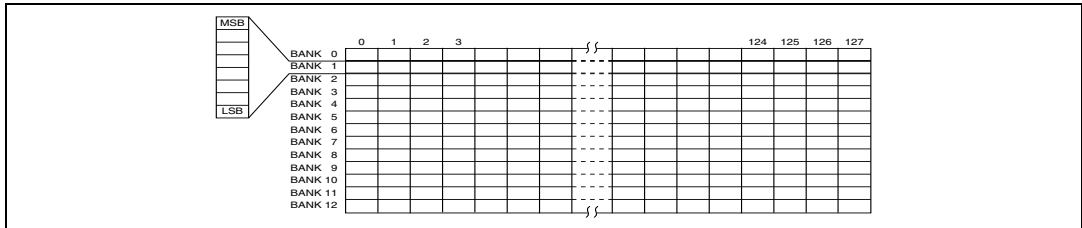

Figure 14. Data RAM Byte organization with D0 = 1

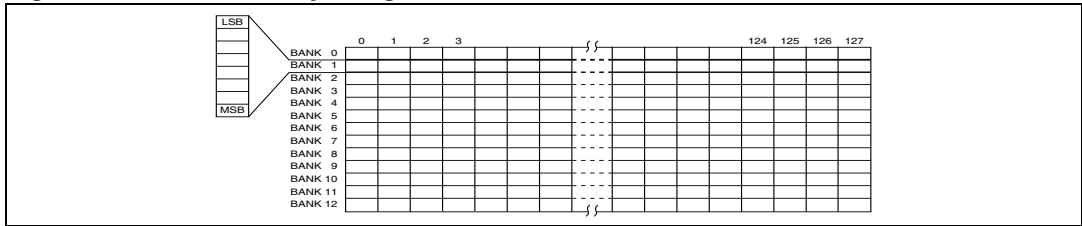

Figure 15. Memory rows vs. row drivers mapping with MY=0, MUX81, icon mode=0,1

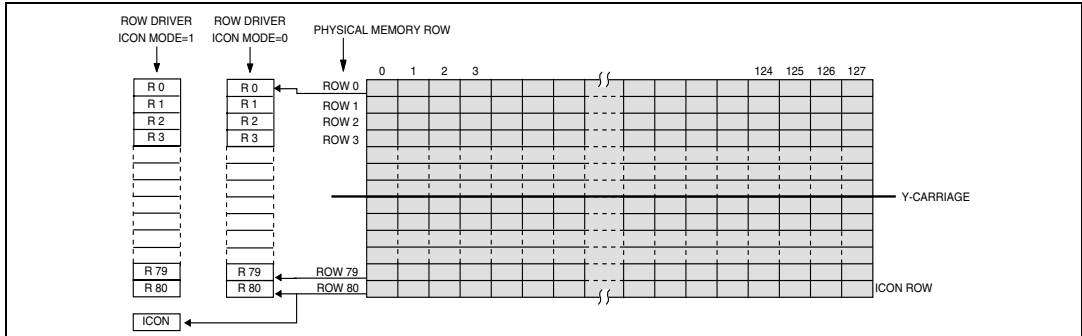

Figure 16. Memory rows vs. row drivers mapping with MY=0, MUX 81, scroll pointer = +3, icon mode=1

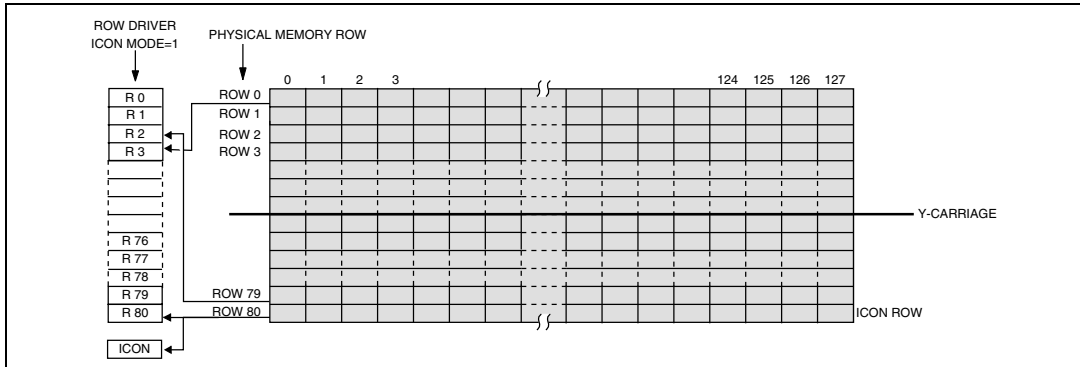

Figure 17. Memory rows vs. row drivers mapping with MY=0, MUX 81, scroll pointer=+3, icon mode=0

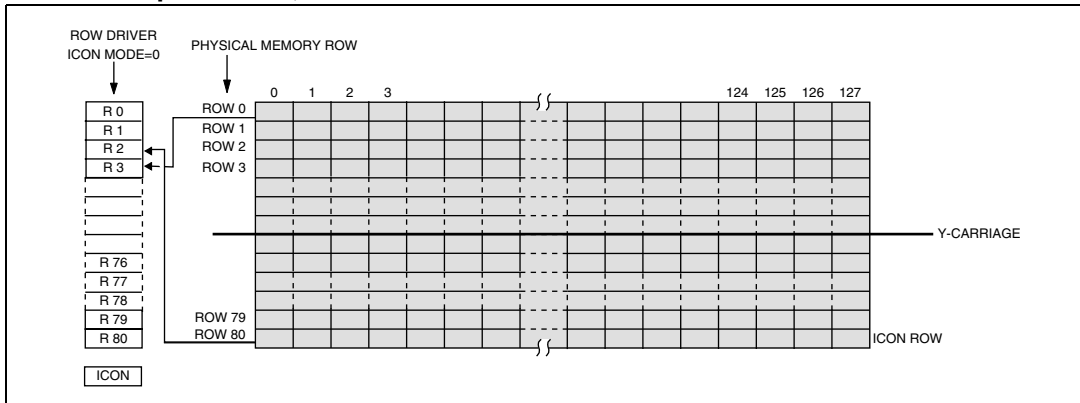

Figure 18. Memory rows vs. row drivers mapping with MUX 65 Y-CARRIAGE<=8 scroll pointer=0, icon mode=1

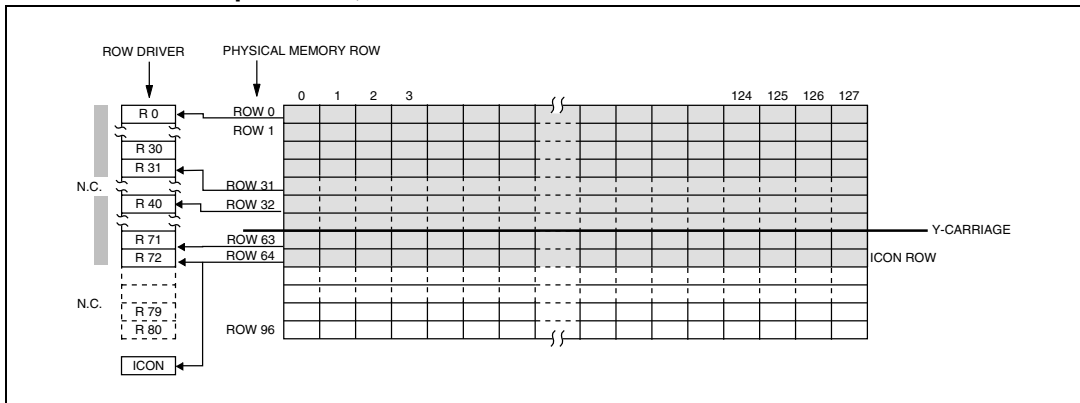

Figure 19. Memory rows vs. row drivers mapping with MUX65, Y-CARRIAGE>8, scroll pointer=0, icon mode=1

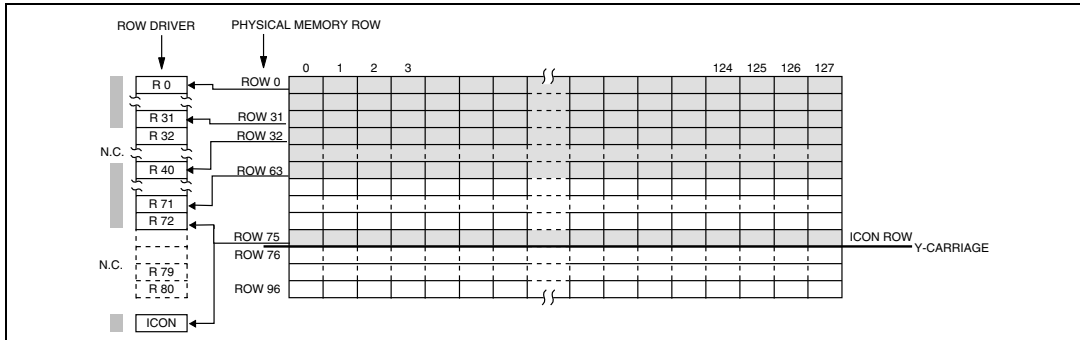

Figure 20. Memory rows vs. row drivers mapping with MUX65, Y-CARRIAGE>8, scroll pointer=3, icon mode=1,

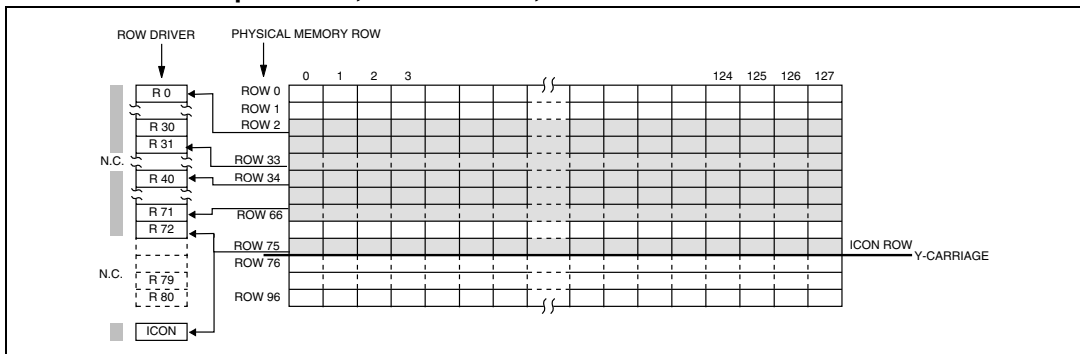

Figure 21. Memory Rows vs. Row drivers mapping with MY=1, MUX81, icon mode 0,1 scroll pointer=0

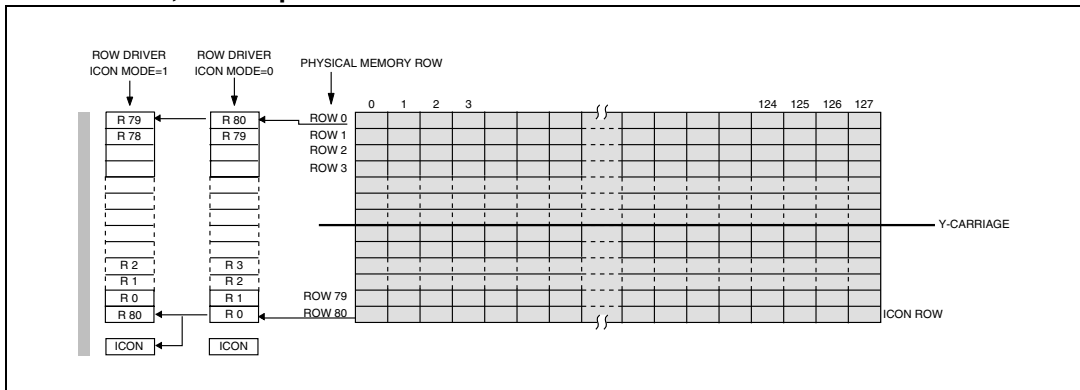

Figure 22. Memory rows vs. row drivers mapping with MY=1, MUX81, scroll offset = +3, icon mode =0

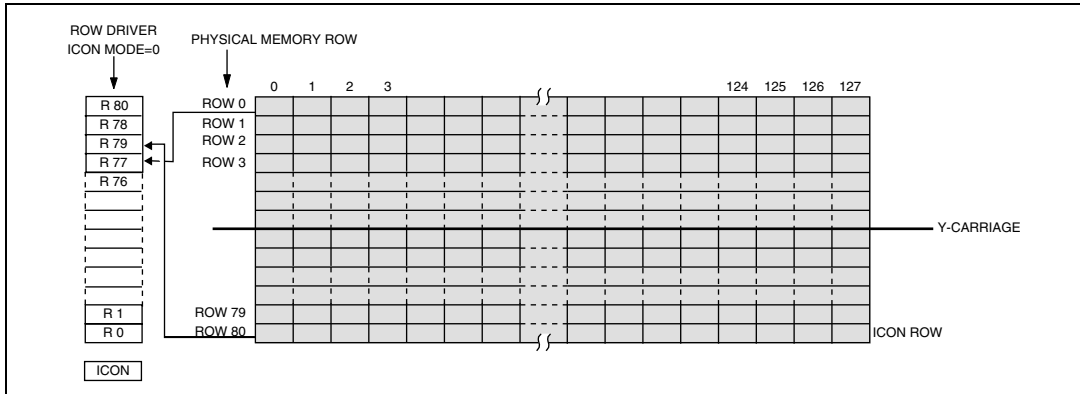

Figure 23. Memory rows vs. row drivers mapping with MY=1, MUX81, scroll offset= +3, icon mode =1

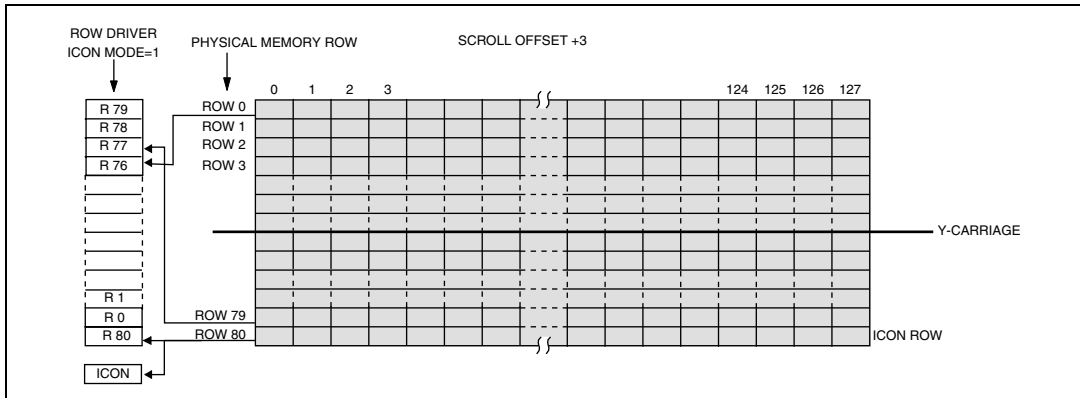

Figure 24. Row drivers vs. LCD panel interconnection in MUX81 mode

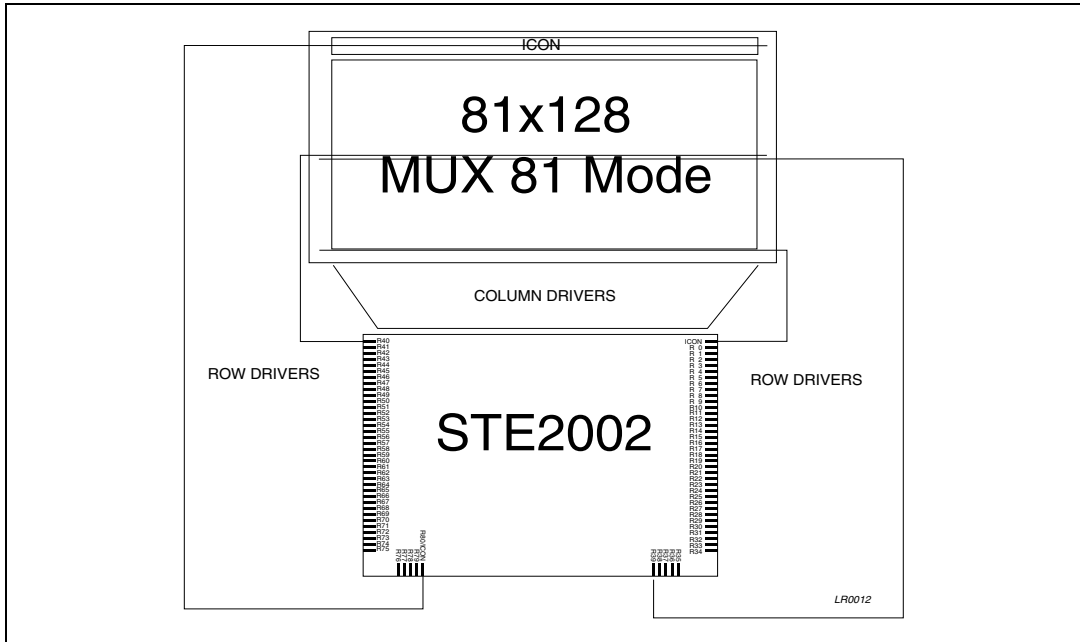

Figure 25. Row drivers vs. LCD panel interconnection in MUX65 mode

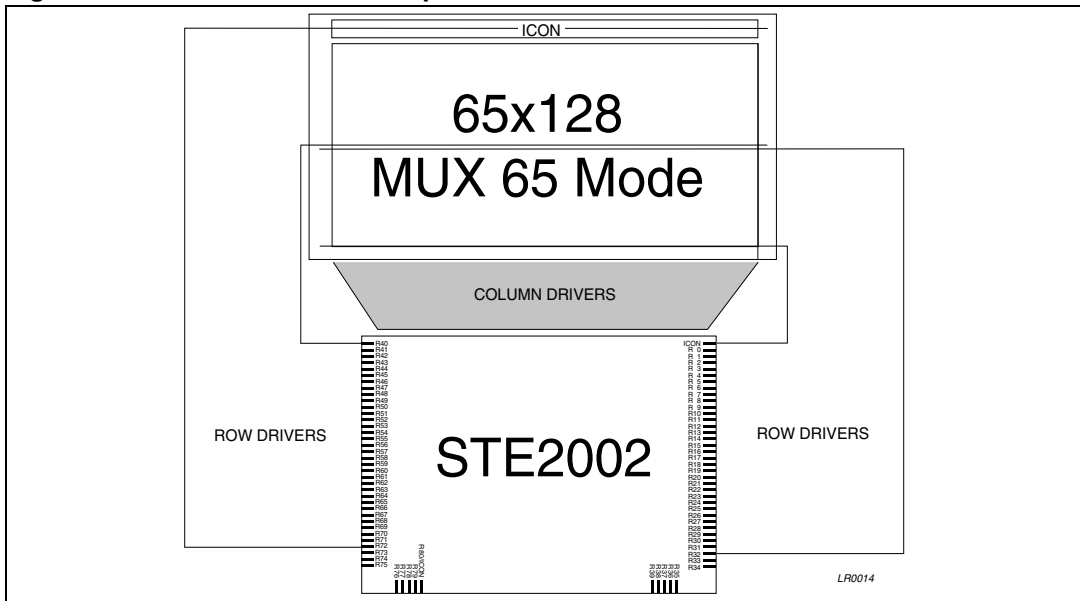

Figure 26. Row drivers vs. LCD panel interconnection in MUX49 mode

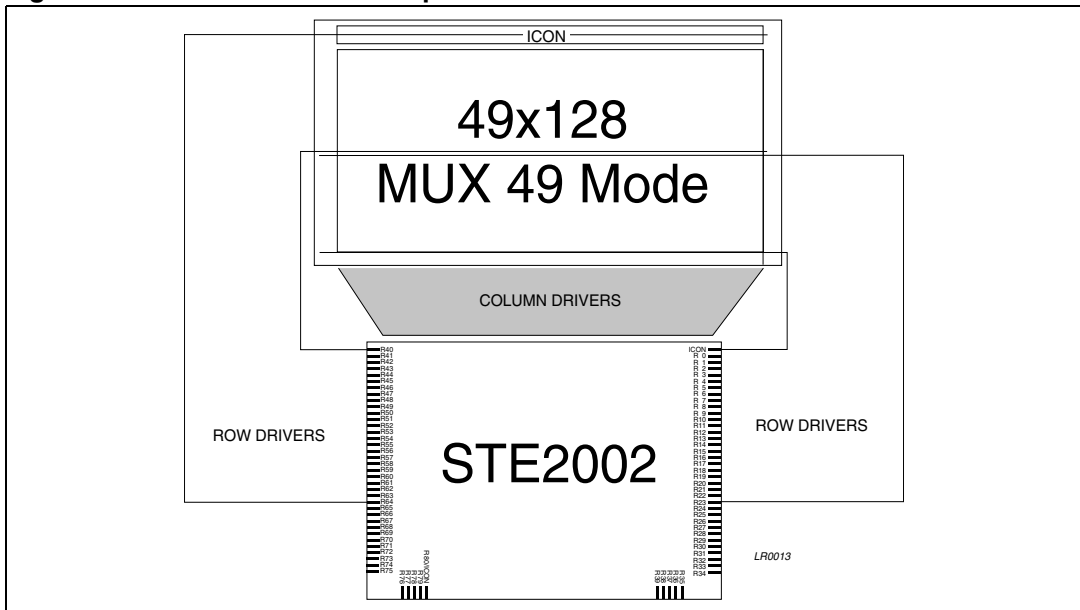
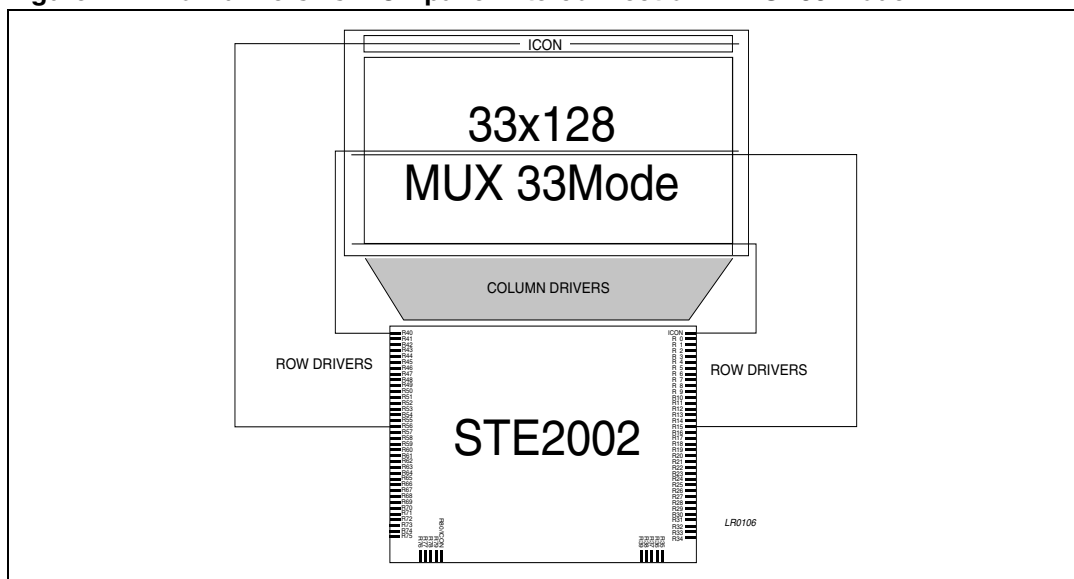

Figure 27. Row drivers vs. LCD panel interconnection in MUX33 mode



4 Instruction set

Two different instructions formats are provided:

- With D/\overline{C} set to LOW
commands are sent to the Control circuitry.
- With D/\overline{C} set to HIGH
the Data RAM is addressed.

Two different instruction set are embedded: the STE2001-like instruction set and the extended instruction set. To select the STE2001-like instruction set the EXT pad has to be connected to a logic LOW (connect to VSS). To select the extended instruction the EXT pad has to be connected to a logic HIGH (connect to VDD1).

The instructions have the syntax summarized in [Table 10](#), (basic-set) and [Table 11](#) (extended set).

4.1 Reset (RES)

At power-on, all internal registers are configured with the default value. The RAM content is not defined. A Reset pulse on RES pad (active low) re-initialize the internal registers content (see [Table 10](#), [Table 11](#), [Table 12](#)). Applying a reset pulse, every on-going communication with the host controller is interrupted. After the power-on, the Software Reset instruction can be used to re-load the reset configuration into the internal registers

The default configurations is: .

- Horizontal addressing ($V = 0$)
- Normal instruction set ($H[1:0] = 0$)
- Normal display ($MX = MY = 0$)
- Display blank ($E = D = 0$)
- Address counter $X[6: 0] = 0$ and $Y[4: 0] = 0$
- Temperature coefficient ($TC[1: 0] = 0$)
- Bias system ($BS[2: 0] = 0$)
- Multiplexing Ratio ($M[1:0]=0$)
- Frame Rate ($FR[1:0]=$ "75Hz")
- Power Down ($PD = 1$)
- Dual Partial Display Disabled ($PE=0$)
- $V_{OP}=0$

A MEMORY BLANK instruction can be executed to clear the RAM content.

4.2 Power down (PD = 1)

When at Power Down, all LCD outputs are kept at V_{SS} (display off). Bias generator and V_{LCD} generator are OFF (V_{LCDOUT} output is discharged to V_{SS} , and then is possible to disconnect V_{LCDOUT}). The internal Oscillator is in off state. An external clock can be provided. The RAM contents is not cleared.

4.3 Memory blanking procedure

This instruction allows to fill the memory with "blank" patterns, in order to delete patterns randomly generated in memory when starting up the device. This instruction substitutes (128X13) single "write" instructions. It is possible to program "Memory Blanking Procedure" only under the following conditions:

- PD bit = 0

The end of the procedure will be notified on the $\overline{\text{BSY_FLG}}$ pad going HIGH (while LOW the procedure is running). Any instruction programmed with $\overline{\text{BSY_FLG}}$ LOW will be ignored that is, no instruction can be programmed for a period equivalent to 128X13 internal write cycles (128X13X1/fclock). The start of Memory blanking procedure will be between one and two fclock cycles from the last active edge (E rising edge for the parallel interface, last SCLK rising edge for the Serial interface, last SCL rising edge for the I²C interface).

4.4 Checker board procedure

This instruction allows to fill the memory with "checker-board" pattern. It is mainly intended to developers, who can now simply obtain complex module test configuration by means of a single instruction. It is possible to program "Checker Board Procedure" only under the following conditions:

- PD bit = 0

The end of the procedure will be notified on the $\overline{\text{BSY_FLG}}$ pad going HIGH, while LOW the procedure is running. Any instruction programmed with $\overline{\text{BSY_FLG}}$ LOW will be ignored, that is, no instruction can be programmed for a period equivalent to 128X13 internal write cycles (128X13X1/fclock). The start of Memory blanking procedure will be between one and two fclock cycles from the last active edge (E rising edge for the parallel interface, last SCLK rising edge for the Serial interface, last SCL rising edge for the I²C interface).

4.5 Scrolling function

The STE2002 can scroll the graphics display in units of raster-rows. The scrolling function is achieved changing the correspondence between the rows of the logical memory map and the output row drivers. The scroll function doesn't affect the data ram content. It is only related to the visualization process. The information output on the drivers is related to the row reading sequence (the 1st row read is output on R0, the 2nd on R1 and so on). Scrolling means reading the matrix starting from a row that is sequentially increased or decreased.

After every scrolling command the offset between the memory address and the memory scanning pointer is increased or decreased by one. The offset range changes in accordance with MUX Rate. After 80th/81th scrolling commands in MUX 81 mode, or after the 64th/65th scrolling commands in mux 65 mode, or after 48nd/49rd scrolling command in MUX 49 mode, or after 32nd/33rd scrolling command in MUX 33 mode, the offset between the memory address and the memory scanning pointer is again zero (Cyclic Scrolling).

A Reset Scrolling Pointer instruction can be executed to force to zero the offset between the memory address and the memory scanning pointer

The Icon Row is not scrolled if ICON MODE =1. If ICON MODE=0 the last row is like a general purpose row and it is scrolled as other rows.

If the DIR Bit is set to a logic zero the offset register is increased by one and the raster is scrolled from top down. If the DIR Bit is set to a logic one the offset register is decreased by one and the raster is scrolled from bottom-up.

Table 7. Scrolling function

Mux rate	Icon mode	Offset range	Description	Icon row driver with MY=0
MUX 33	1	0-31	ICON ROW NOT SCROOLED	R56
MUX 33	0	0-32	33 LINE GRAPHIC MATRIX	R56
MUX 49	1	0-47	ICON ROW NOT SCROOLED	R64
MUX 49	0	0-48	49 LINE GRAPHIC MATRIX	R64
MUX 65	1	0-63	ICON ROW NOT SCROOLED	R72
MUX 65	0	0-64	65 LINE GRAPHIC MATRIX	R72
MUX 81	1	0-79	ICON ROW NOT SCROOLED	R80
MUX 81	0	0-80	81 LINE GRAPHIC MATRIX	R80

4.6 Dual partial display

If the PE Bit is set to a logic one the dual partial display mode is enabled. Eight partial display modes are available. The offset of the two partial display zones is row by row programmable. The Icon row is accessed last in each partial display frame. Two sets of register for the HV-generator parameters are provided (PRS[1:0], Vop[6:0], BS[2:0], CP[2:0]). This allows switching from normal mode to partial display mode applying one instruction. The HV generator is automatically re configured using the parameters related to the enabled mode. The parameters of the two sets of registers with the same function are located in the same position of the instruction set. The registers related to the normal mode are accessible when normal mode (PE=0) is selected, the others are accessible when the partial display mode is enabled (PE=1). To Setup PRS[1:0], Vop[6:0], BS[2:0], CP[2:0] values the instruction flow proposed in Fig.46 must be followed. To setup Partial Display Sectors Start Address and Partial Display Mode no particular instruction flow has to be followed.

Table 8. Dual partial display

PD2	PD1	PD0	Section 1	Section2	Reset state
0	0	0	0	8 + Icon Row	000
0	0	1	8	0 + Icon Row	
0	1	0	8	8 + Icon Row	
0	1	1	0	16 + Icon Row	
1	0	0	16	0 + Icon Row	
1	0	1	8	16 + Icon Row	
1	1	0	16	8 + Icon Row	
1	1	1	16	16 + Icon Row	

5 Bus interfaces

To provide the widest flexibility and ease of use the STE2002 features three different methods for interfacing the host Controller. To select the desired interface the SEL1 and SEL2 pads need to be connected to a logic LOW (connect to GND) or a logic HIGH (connect to VDD). All the I/O pins of the unused interfaces must be connected to GND.

All interfaces are working while the STE2002 is in Power Down

Table 9. Bus interface

SEL2	SEL1	Interface	Note
0	0	I ² C	Read and Write; Fast and High Speed Mode
0	1	Serial	Read and Write
1	0	Parallel	Read and Write
1	1		Not Used

5.1 I²C interface

The I²C interface is a fully complying I²C bus specification, selectable to work in both Fast (400kHz Clock) and High Speed Mode (3.4MHz).

This bus is intended for communication between different Ics. It consists of two lines: one bi-directional for data signals (SDA) and one for clock signals (SCL). Both the SDA and SCL lines must be connected to a positive supply voltage via an active or passive pull-up.

The following protocol has been defined:

- Data transfer may be initiated only when the bus is not busy.
- During data transfer, the data line must remain stable whenever the clock line is high. Changes in the data line while the clock line is high will be interpreted as control signals.

Accordingly, the following bus conditions have been defined:

BUS not busy: Both data and clock lines remain High.

Start Data Transfer: A change in the state of the data line, from High to Low, while the clock is High, define the START condition.

Stop Data Transfer: A Change in the state of the data line, from low to High, while the clock signal is High, defines the STOP condition.

Data Valid: The state of the data line represents valid data when after a start condition, the data line is stable for the duration of the High period of the clock signal. The data on the line may be changed during the Low period of the clock signal. There is one clock pulse per bit of data.

Each data transfer is initiated with a start condition and terminated with a stop condition. The number of data bytes transferred between the start and the stop conditions is not limited. The information is transmitted byte-wide and each receiver acknowledges with the ninth bit.

By definition, a device that gives out a message is called "transmitter", the receiving device that gets the signals is called "receiver". The device that controls the message is called "master". The devices that are controlled by the master are called "slaves"

Acknowledge. Each byte of eight bits is followed by one acknowledge bit. This acknowledge bit is a low level put on the bus by the receiver, whereas the master generates an extra acknowledge related clock pulse.

A slave receiver which is addressed must generate an acknowledge after the reception of each byte. Also, a master receiver must generate an acknowledge after the reception of each byte that has been clocked out of the slave transmitter. The device that acknowledges has to pull down the SDA_IN line during the acknowledge clock pulse. Of course, setup and hold time must be taken into account. A master receiver must signal an end-of-data to the slave transmitter by not generating an acknowledge on the last byte that has been clocked out of the slave. In this case, the transmitter must leave the data line High to enable the master to generate the STOP condition.

Connecting SDA_IN and SDA_OUT together the SDA line become the standard data line. Having the acknowledge output (SDAOUT) separated from the serial data line is advantageous in Chip-On-Glass (COG) applications. In COG applications where the track resistance from the SDAOUT pad to the system SDA line can be significant, a potential divider is generated by the bus pull-up resistor and the Indium Tin Oxide (ITO) track resistance. It is possible that during the acknowledge cycle the STE2002 will not be able to create a valid logic 0 level. By splitting the SDA input from the output the device could be used in a mode that ignores the acknowledge bit. In COG applications where the acknowledge cycle is required, it is necessary to minimize the track resistance from the SDACK pad to the system SDA line to guarantee a valid LOW level.

To be compliant with the I²C-bus Hs-mode specification the STE2002 is able to detect the special sequence "S00001xxx". After this sequence no acknowledge pulse is generated.

Since no internal modification are applied to work in Hs-mode, the device is able to work in Hs-mode without detecting the master code.

Figure 28. Bit transfer and START,STOP conditions definition

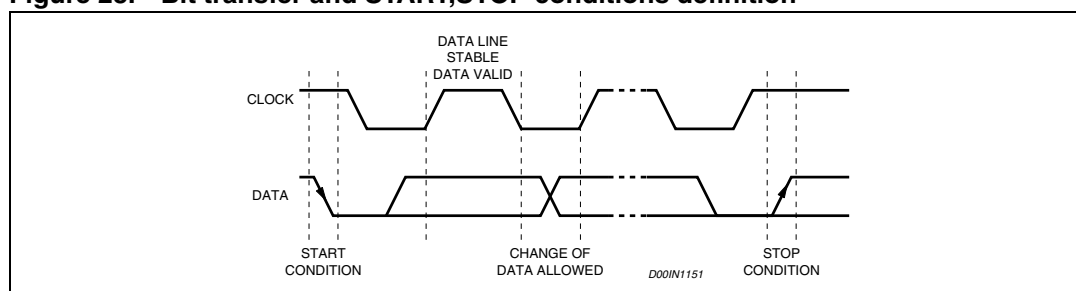
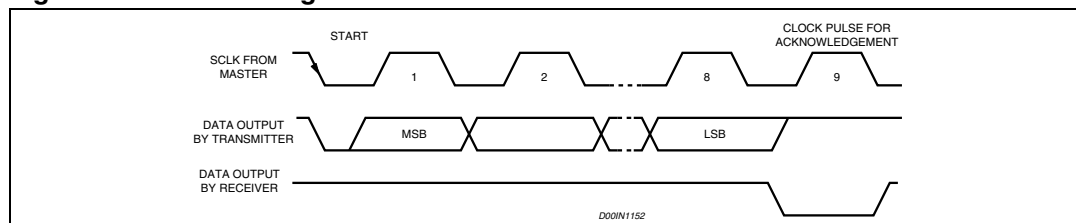

Figure 29. Acknowledgment on the I²C-bus



5.1.1 Communication protocol

The STE2002 is an I²C slave. The access to the device is bi-directional since data write and status read are allowed.

Four are the device addresses available for the device. All have in common the first 5 bits (01111). The two least significant bit of the slave address are set by connecting the SA0 and SA1 inputs to a logic 0 or to a logic 1.

To start the communication between the bus master and the slave LCD driver, the master must initiate a START condition. Following this, the master sends an 8-bit byte, shown in Fig. 30, on the SDA bus line (Most significant bit first). This consists of the 7-bit Device select Code, and the 1-bit Read/Write Designator (R/\overline{W}).

All slaves with the corresponding address acknowledge in parallel, all the others will ignore the I²C-bus transfer.

Writing mode

If the R/W bit is set to logic 0 the STE2002 is set to be a receiver. After the slaves acknowledge one or more command word follows to define the status of the device.

A command word is composed by two bytes. The first is a control byte which defines the Co and D/\overline{C} values, the second is a data byte (fig 31). The Co bit is the command MSB and defines if after this command will follow one data byte and an other command word or if will follow a stream of data (Co = 1 Command word, Co = 0 Stream of data). The D/\overline{C} bit defines whether the data byte is a command or RAM data (D/\overline{C} = 1 RAM Data, D/\overline{C} = 0 Command). If Co =1 and D/\overline{C} = 0 the incoming data byte is decoded as a command, and if Co =1 and D/\overline{C} =1, the following data byte will be stored in the data RAM at the location specified by the data pointer.

Every byte of a command word must be acknowledged by all addressed units.

After the last control byte, if D/\overline{C} is set to a logic 1 the incoming data bytes are stored inside the STE2002 Display RAM starting at the address specified by the data pointer. The data pointer is automatically updated after every byte written and in the end points to the last RAM location written.

Every byte must be acknowledged by all addressed units.

Reading mode

If the R/W bit is set to logic 1 the chip will output data immediately after the slave address. If the D/C bit sent during the last write access, is set to a logic 0, the byte read is the status byte.

Figure 30. Communication protocol

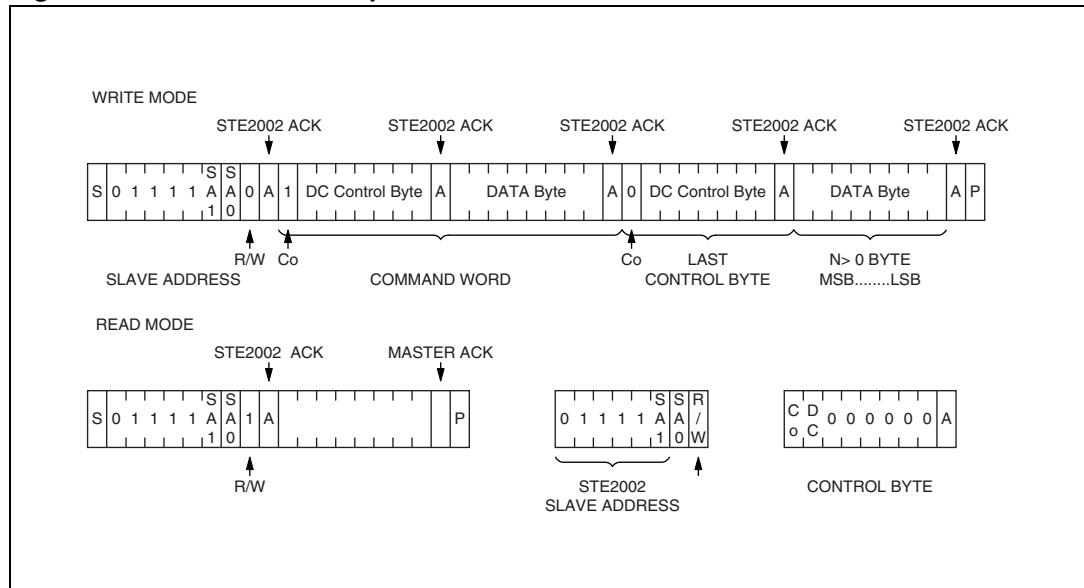

5.2 Serial interface

The STE2002 serial Interface is a bidirectional link between the display driver and the application supervisor.

It consists of five lines: two for data signals (SDIN, SOUT), one for clock signals (SCLK), one for the peripheral enable (\overline{SCE}) and one for mode selection (SD/\overline{C}).

The serial interface is active only if the SCE line is set to a logic 0. When \overline{SCE} line is high the serial peripheral power consumption is zero. While \overline{SCE} pin is high the serial interface is kept in reset.

The STE2002 is always a slave on the bus and receive the communication clock on the SCLK pin from the master.

Information are exchanged byte-wide. During data transfer, the data line is sampled on the positive SCLK edge.

SD/\overline{C} line status indicates whether the byte is a command ($SD/\overline{C} = 0$) or RAM data ($SD/\overline{C} = 1$); it is read on the eighth SCLK clock pulse during every byte transfer.

If \overline{SCE} stays low after the last bit of a command/data byte, the serial interface expects the MSB of the next byte at the next SCLK positive edge.

A reset pulse on \overline{RES} pin interrupts the transmission. No data is written into the data RAM and all the internal registers are cleared.

If \overline{SCE} is low after the positive edge of \overline{RES} , the serial interface is ready to receive data.

Throughout SOUT can be read only the driver I²C slave address. The Command sequence that allows to read I²C slave address is reported in Fig. 34 & 35. SOUT is in High impedance in steady state and during data write.

It is possible to short circuit DOUT and SDIN and read I2C address without any additional lines.

Figure 31. Serial bus protocol - one byte transmission

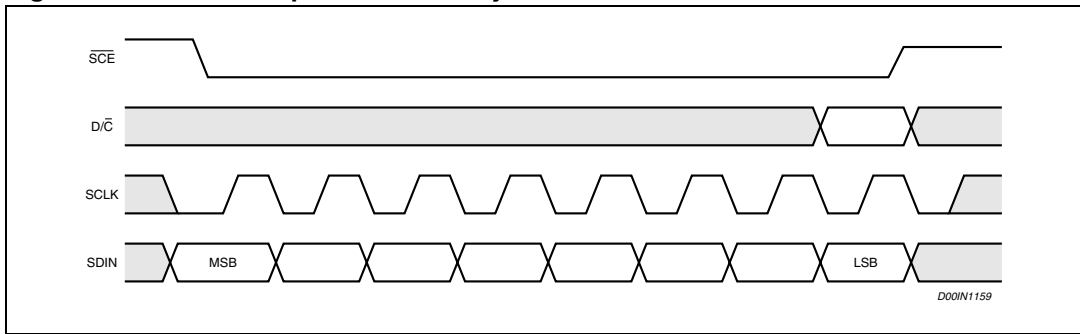

Figure 32. Serial bus protocol - several byte transmission

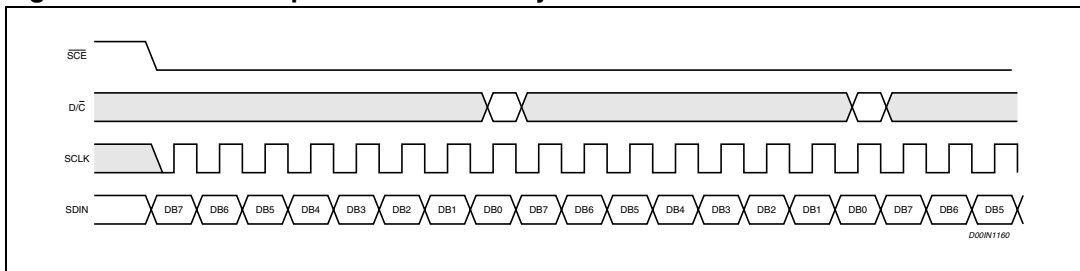

Figure 33. Serial bus protocol - several byte transmission

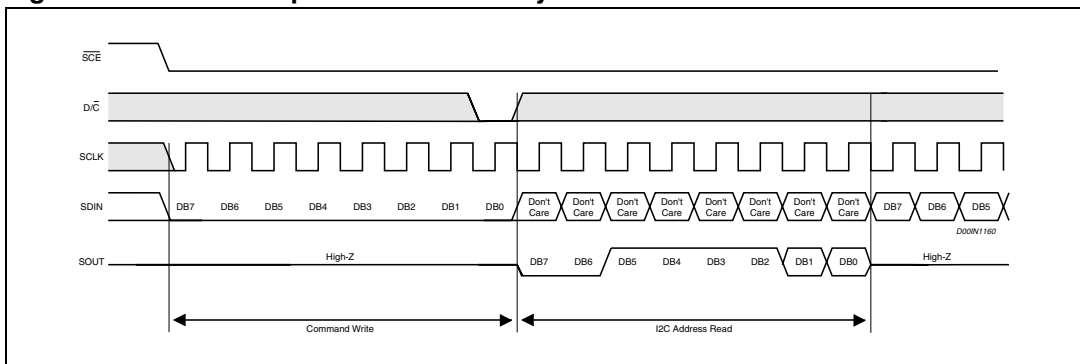
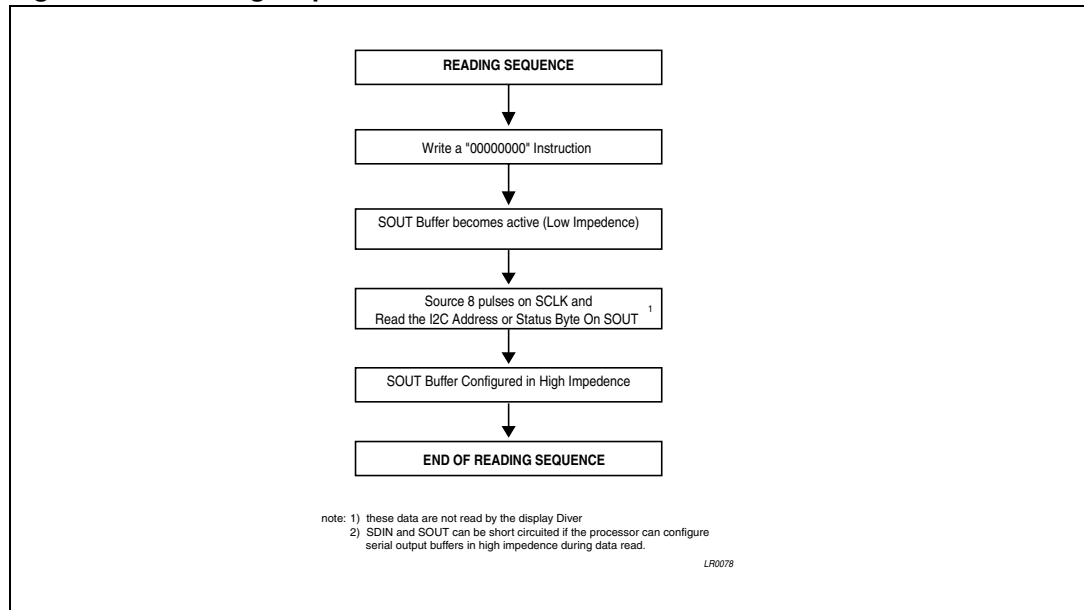

Figure 34. Reading sequence



5.3 Parallel interface

The STE2002 parallel Interface is a bidirectional link between the display driver and the application supervisor. It consists of eleven lines: eight data lines (from DB7 to DB0) and three control lines. The control lines are: enable (E) for data latch, PD/C for mode selection and R/W for reading or writing.

The data lines and the control line values are internally latched on E rising edge (fig. 50).

When the parallel interface is selected, if R/W line is set to “one”, D0-D7 lines are configured as output drivers (low impedance) and it is possible to read the driver I²C address (Fig. 51)

Table 10. STE2001-like instruction set

Instruction	D/C	R/W	B7	B6	B5	B4	B3	B2	B1	B0	Description
H=0 or H=1											
	0	0	0	0	0	0	0	0	0	0	Read I ² C Address (with Serial Interface only)
Function Set	0	0	0	0	1	MX	MY	PD	V	H[0]	Power Down Management; Entry Mode;
Read Status Byte	0	1	PD	A1	A2	D	E	MX	MY	DO	(I ² C interface only)
Write Data	1	0	D7	D6	D5	D4	D3	D2	D1	D0	Writes data to RAM

Table 10. STE2001-like instruction set (continued)

Instruction	D/C	R/W	B7	B6	B5	B4	B3	B2	B1	B0	Description
H=0											
Memory Blank	0	0	0	0	0	0	0	0	0	1	Starts Memory Blank Procedure
Scroll	0	0	0	0	0	0	0	0	1	DIR	Scrolls by one Row UP or DOWN
V _{LCD} Range Setting	0	0	0	0	0	0	0	1	0	PRS[0]	V _{LDC} programming range selection
Display Control	0	0	0	0	0	0	1	D	0	E	Select Display Configuration
Set CP Factor	0	0	0	0	0	1	0	S2	S1	S0	Charge Pump Multiplication factor
Set RAM Y	0	0	0	1	0	0	Y3	Y2	Y1	Y0	Set Horizontal (Y) RAM Address
Set RAM X	0	0	1	X6	X5	X4	X3	X2	X1	X0	Set Vertical (X) RAM Address
H=1											
Checker Board	0	0	0	0	0	0	0	0	0	1	Starts Checker Board Procedure
Multiplex Select	0	0	0	0	0	0	0	0	1	MUX	Selects MUX factor
TC Select	0	0	0	0	0	0	0	1	TC1	TC0	Set Temperature Coefficient for V _{LDC}
Output Address	0	0	0	0	0	0	1	DO	A1	A2	No function
Bias Ratios	0	0	0	0	0	1	0	BS2	BS1	BS0	Set desired Bias Ratios
Reserved	0	0	0	1	X	X	X	X	X	X	Not to be used
Set V _{OP}	0	0	1	OP6	OP5	OP4	OP3	OP2	OP1	OP0	V _{OP} register Write instruction

Table 11. Extended instruction set

Instruction	D/C	R/W	B7	B6	B5	B4	B3	B2	B1	B0	Description
H independent instructions											
NOP	0	0	0	0	0	0	0	0	0	0	Read I ² C Address (with Serial Interface only)
Function Set	0	0	0	0	1	MX	MY	PD	H[1]	H[0]	Power Down Management; Entry Mode; Extended Instruction Set
Read Status Byte	0	1	PD	0	0	D	E	MX	MY	DO	(I ² C interface only)
Write Data	1	0	D7	D6	D5	D4	D3	D2	D1	D0	Writes data to RAM
H=[0;0] RAM commands											
Memory Blank	0	0	0	0	0	0	0	0	0	1	Starts Memory Blank Procedure
Scroll	0	0	0	0	0	0	0	0	1	DIR	Scrolls by one Row UP or DOWN
V _{LCD} Range Setting	0	0	0	0	0	0	0	1	PRS[1]	PRS[0]	V _{LDC} programming range selection
Display Control	0	0	0	0	0	0	1	D	0	E	Select Display Configuration
Set CP Factor	0	0	0	0	0	1	0	S2	S1	S0	Charge Pump Multiplication factor
Set RAM Y	0	0	0	1	0	0	Y3	Y2	Y1	Y0	Set Horizontal (Y) RAM Address
Set RAM X	0	0	1	X6	X5	X4	X3	X2	X1	X0	Set Vertical (X) RAM Address
H=[0;1]											
Checker Board	0	0	0	0	0	0	0	0	0	1	Starts Checker Board Procedure
	0	0	0	0	0	0	0	0	1	V	Vertical Addressing Mode
TC Select	0	0	0	0	0	0	0	1	TC1	TC0	Set Temperature Coefficient for V _{LDC}
Data Format	0	0	0	0	0	0	1	DO	0	0	MSB Position
Bias Ratios	0	0	0	0	0	1	0	BS2	BS1	BS0	Set desired Bias Ratios
	0	0	0	1	X	X	X	X	X	X	Reserved
Set V _{OP}	0	0	1	OP6	OP5	OP4	OP3	OP2	OP1	OP0	V _{OP} register Write instruction

Table 11. Extended instruction set

Instruction	D/C	R/W	B7	B6	B5	B4	B3	B2	B1	B0	Description
H=[1;0]											
	0	0	0	0	0	0	0	0	0	1	Software RESET
	0	0	0	0	0	0	0	0	1	PE	Partial Enable
	0	0	0	0	0	0	0	1	FR1	FR0	Frame rate Control
	0	0	0	0	0	0	1	0	M[1]	M[0]	Mux Ratio
Partial mode	0	0	0	0	0	1	0	PD2	PD1	PD0	Partial Display Config
	0	0	0	1	PDY5	PDY4	PDY3	PDY2	PDY1	PDY0	1 st Sector Start Address
	0	0	1	PDY6	PDY5	PDY4	PDY3	PDY2	PDY1	PDY0	2 nd Sector Start Address
H=[1;1]											
	0	0	0	0	0	0	0	0	0	1	Scrolling Pointer Reset
	0	0	0	0	0	0	0	0	1	X	Not Used
	0	0	0	0	0	0	0	1	X	X	Not Used
	0	0	0	0	0	0	1	T2	T1	T0	Set Temperature Coefficient for V _{LDC}
	0	0	0	0	0	1	X	X	X	X	Not Used
	0	0	0	1	0	0	YC-3	YC-2	YC-1	YC-0	Y-CARRIAGE RETURN
	0	0	1	XC-6	XC-5	XC-4	XC-3	XC-2	XC-1	XC-0	X CARRIAGE RETURN

Table 12. Explanations of symbols

Bit	0	1	Reset state
DIR	Scroll by one down	Scroll by one up	
PD	Device fully working	Device in power down	1
V	Horizontal addressing	Vertical addressing	0
MX	Normal X axis addressing	X axis address is mirrored.	0
MY	Image is displayed not vertically mirrored	Image is displayed vertically mirrored	0
DO	MSB on TOP	MSB on BOTTOM	0
PE	Partial Display disabled	Partial Display enabled	0
H[0]	Select page 0	Select page 1	0
MUX	MUX 65	MUX 33	0

Table 13. Page number

H[1]	H[0]	Description	Reset state
0	0	Page 0	Page 0
0	1	Page 1	
1	0	Page 2	
1	1	Page 3	

Table 14. Display mode

D	E	Description	Reset state
0	0	display blank	D=0 E=0
0	1	all display segments on	
1	0	normal mode	
1	1	inverse video mode	

Table 15. Frame rate control

FR[1]	FR[0]	Description	Reset state
0	0	65Hz	75Hz
0	1	70Hz	
1	0	75Hz	
1	1	80Hz	

Table 16. VLCD range selection

PRS[1]	PRS[0]	Description	Reset State
0	0	2.94	
0	1	6.78	
1	0	10.62	
1	1	Not Used	

Table 17. Multiplexing ratio

M[1]	M[0]	Description	Reset state
0	0	49	01
0	1	65	
1	0	81	
1	1	Not Used	

Table 18. Temperature coefficient

T2	T1	T0	Description	Reset state
0	0	0	VLCD temperature Coefficient 0	000
0	0	1	VLCD temperature Coefficient 1	
0	1	0	VLCD temperature Coefficient 2	
0	1	1	VLCD temperature Coefficient 3	
1	0	0	VLCD temperature Coefficient 4	
1	0	1	VLCD temperature Coefficient 5	
1	1	0	VLCD temperature Coefficient 6	
1	1	1	VLCD temperature Coefficient 7	

Table 19. TC1 & TC0 temperature coefficients

TC1	TC0	Description	Reset state
0	0	VLCD temperature Coefficient 0	00
0	1	VLCD temperature Coefficient 2	
1	0	VLCD temperature Coefficient 3	
1	1	VLCD temperature Coefficient 6	

Table 20. Charge pump multiplication factor

CP2	CP1	CP0	Description	Reset state
0	0	0	Multiplication Factor X2	000
0	0	1	Multiplication Factor X3	
0	1	0	Multiplication Factor X4	
0	1	1	Multiplication Factor X5	
1	0	0	Multiplication Factor X6	
1	0	1	NOT USED	
1	1	0	NOT USED	
1	1	1	AUTOMATIC	

Table 21. Bias ratio

BS2	BS1	BS0	Description	Reset state
0	0	0	Bias Ratio equal to 7	000
0	0	1	Bias Ratio equal to 6	
0	1	0	Bias Ratio equal to 5	
0	1	1	Bias Ratio equal to 4	
1	0	0	Bias Ratio equal to 3	
1	0	1	Bias Ratio equal to 2	
1	1	0	Bias Ratio equal to 1	
1	1	1	Bias Ratio equal to 0	

Table 22. Y carriage return register

Y-C[3]	Y-C[2]	Y-C[1]	Y-C[0]	Description	Reset state
0	0	0	0		1000
0	0	0	1	Y-CARRIAGE =1	
0	0	1	0	Y-CARRIAGE =2	
0	0	1	1	Y-CARRIAGE =3	
0	1	0	0	Y-CARRIAGE =4	
0	1	0	1	Y-CARRIAGE =5	
.	.	.	.		
1	0	1	0	Y-CARRIAGE =10	
1	0	1	1	Y-CARRIAGE =11	
1	1	0	0	Y-CARRIAGE =12	

Table 23. Partial display configuration

PD2	PD1	PD0	Section 1	Section2	Reset state
0	0	0	0	8 + Icon Row	000
0	0	1	8	0 + Icon Row	
0	1	0	8	8 + Icon Row	
0	1	1	0	16 + Icon Row	
1	0	0	16	0 + Icon Row	
1	0	1	8	16 + Icon Row	
1	1	0	16	8 + Icon Row	
1	1	1	16	16 + Icon Row	

Figure 35. Host processor interconnection with I2C interface

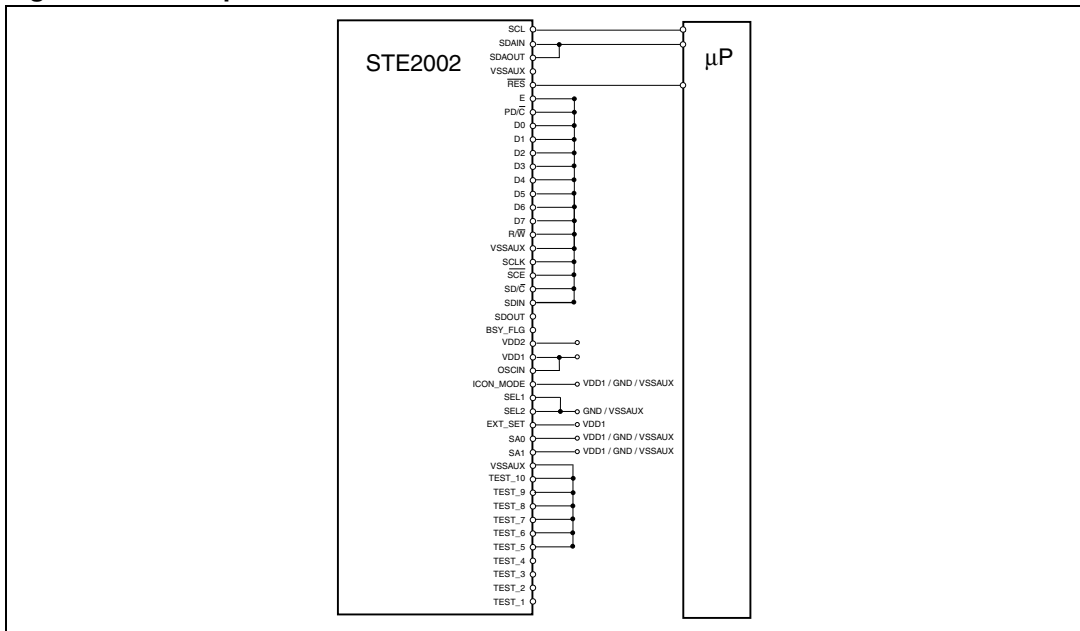

Figure 36. Host processor interconnection with serial interface

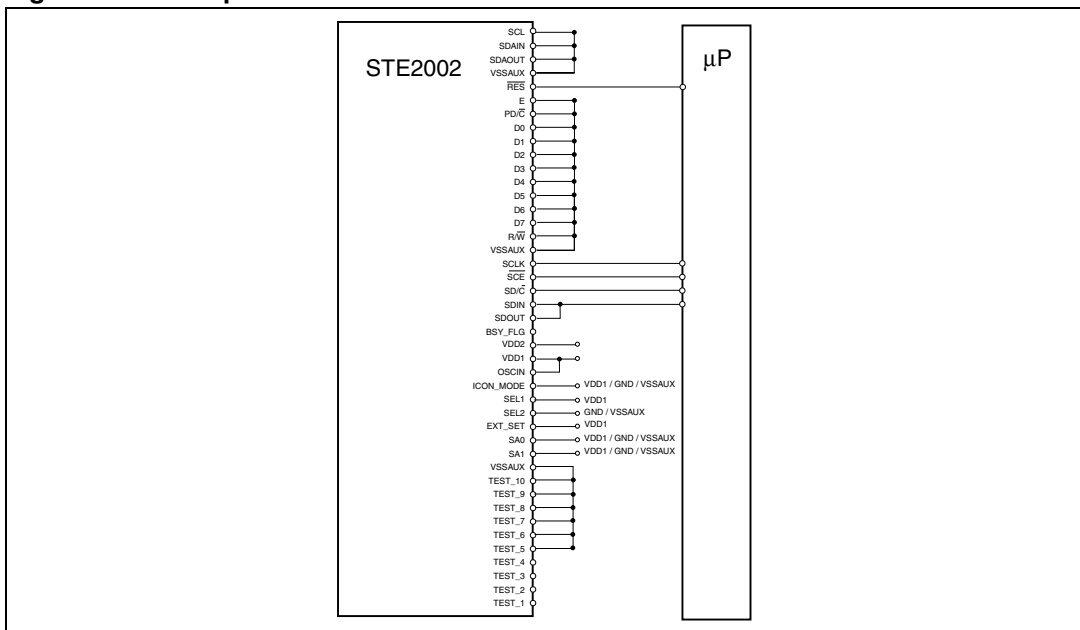

Figure 37. Host processor interconnection with parallel interface

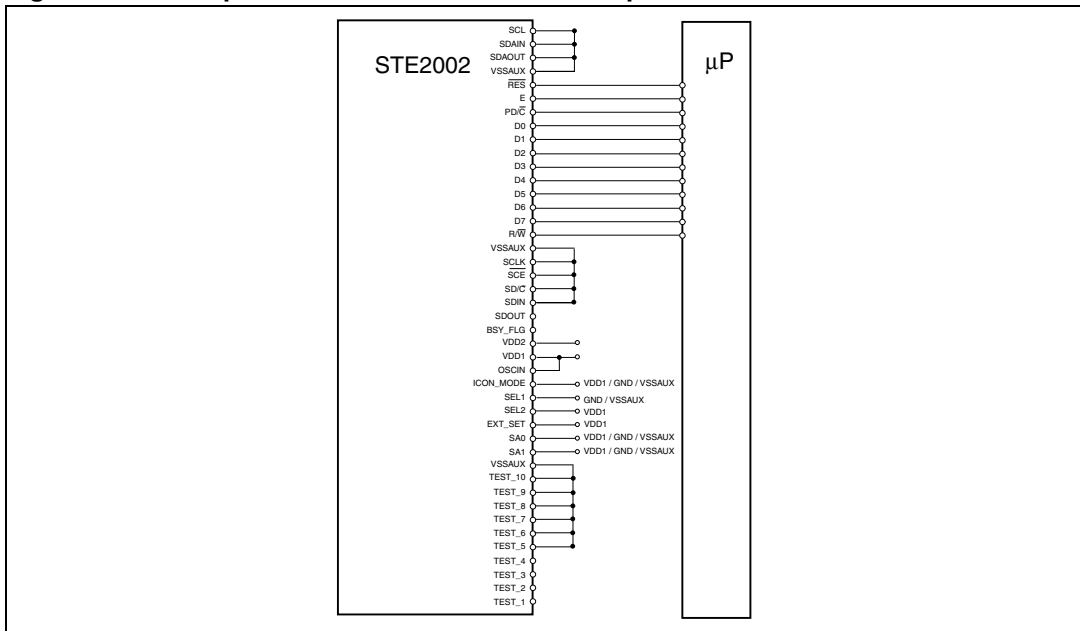

Figure 38. application schematic using an external lcd Voltage Generator

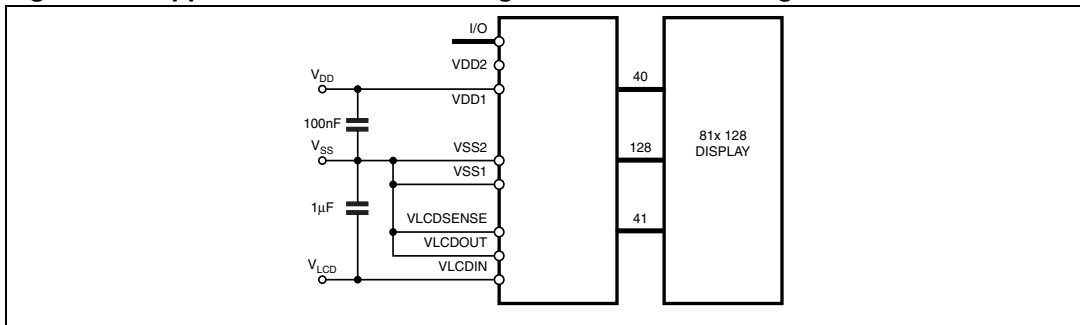

Figure 39. Application schematic using the internal LCD voltage generator and two separate supplies

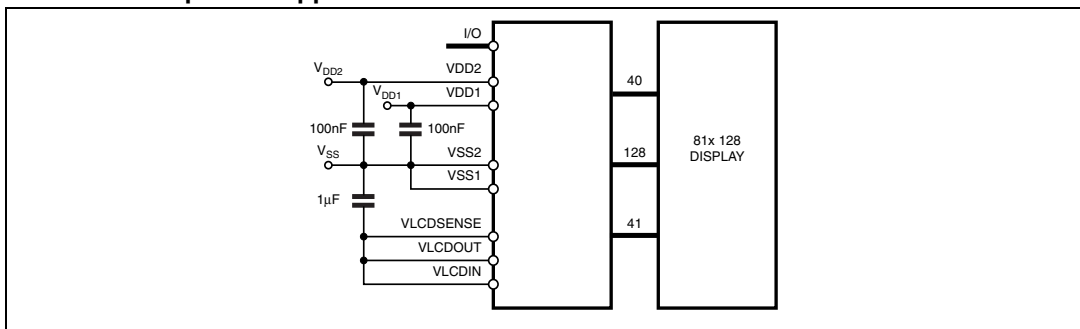

Figure 40. Application schematic using the internal LCD voltage generator and a single supply

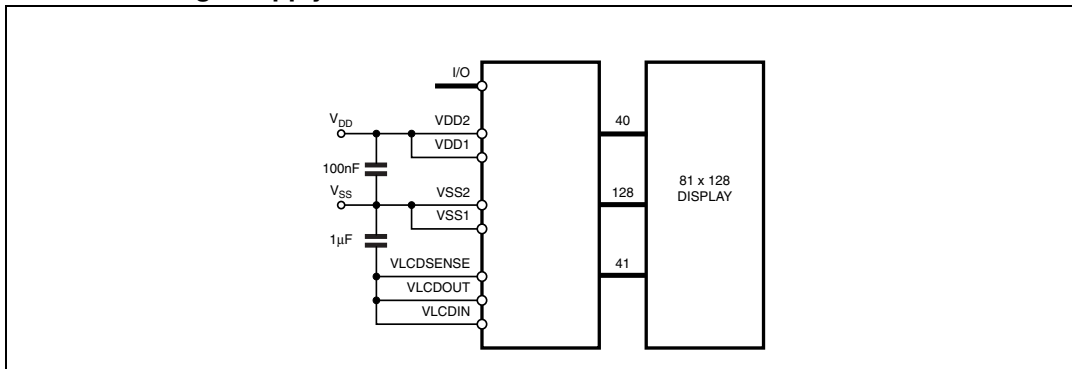

Figure 41. Power-up sequence

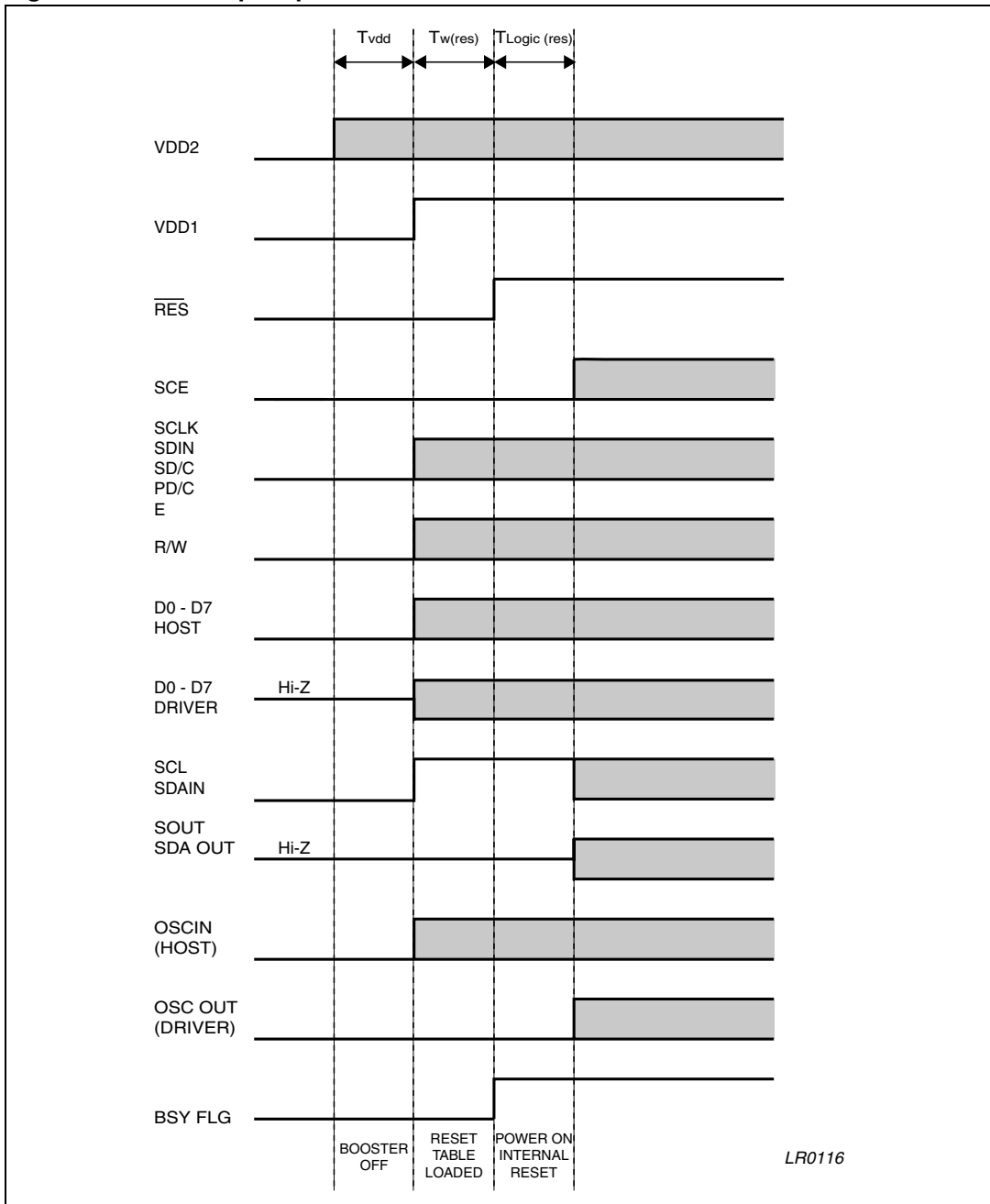

Figure 42. Power-OFF sequence

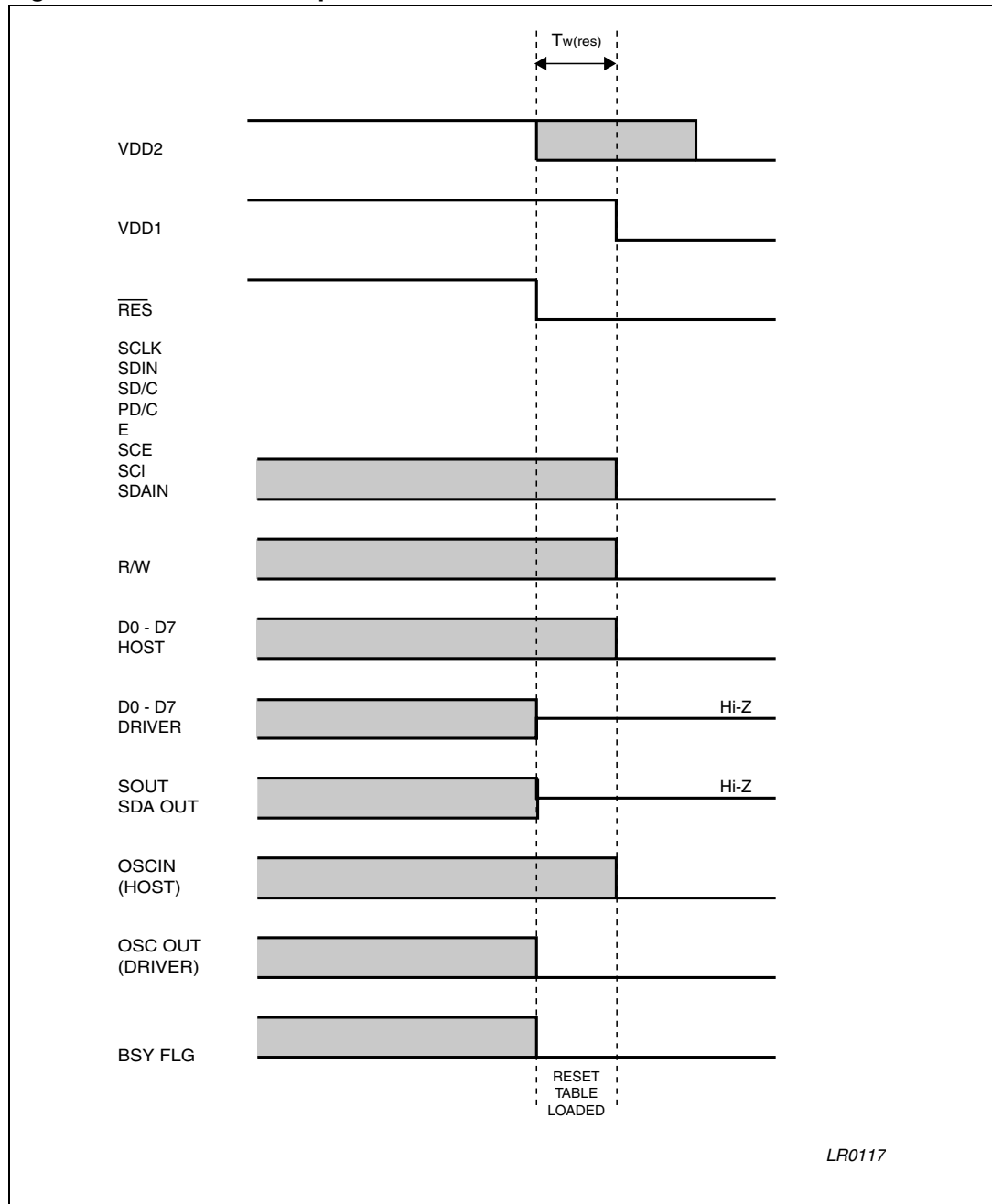

Figure 43. Initialization with built-in booster

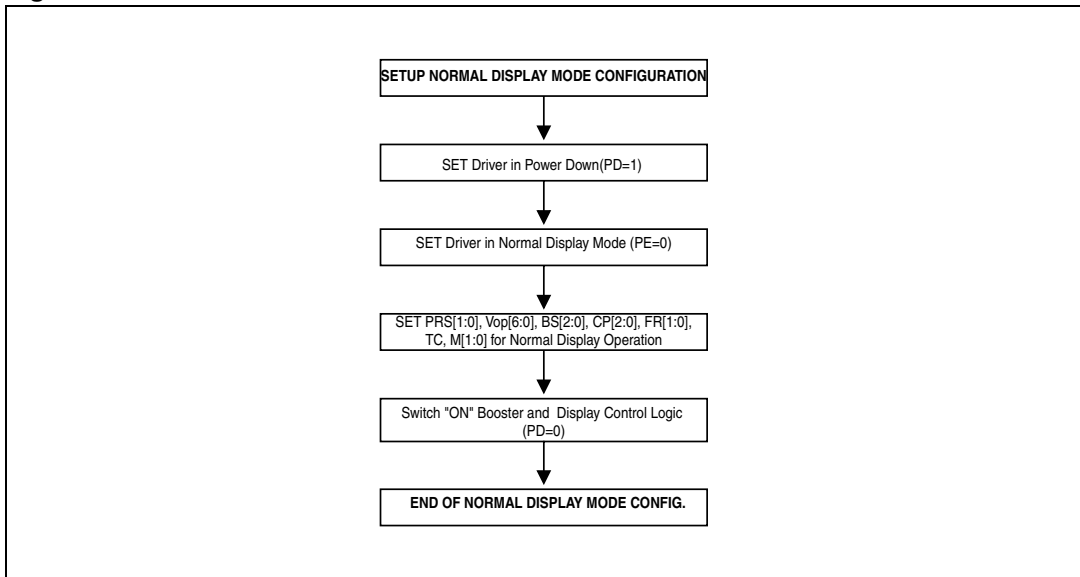

Figure 44. Dual partial display enabling instruction flow

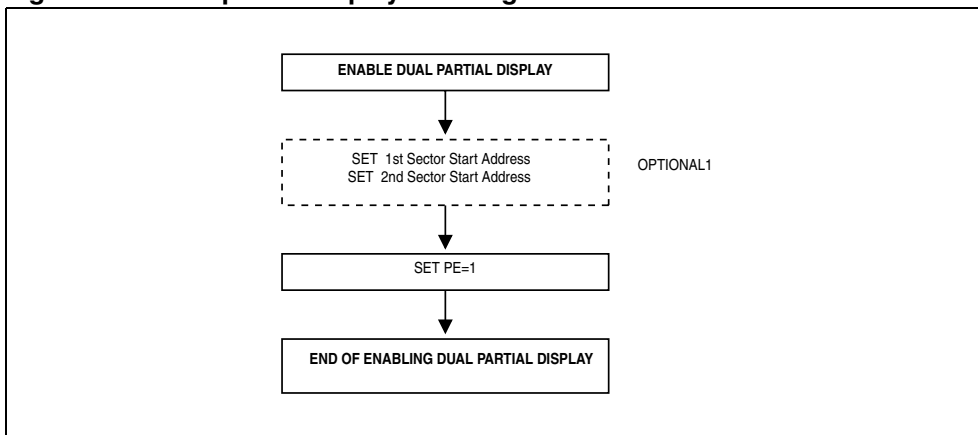

Figure 45. Dual partial display mode configuration or duty change

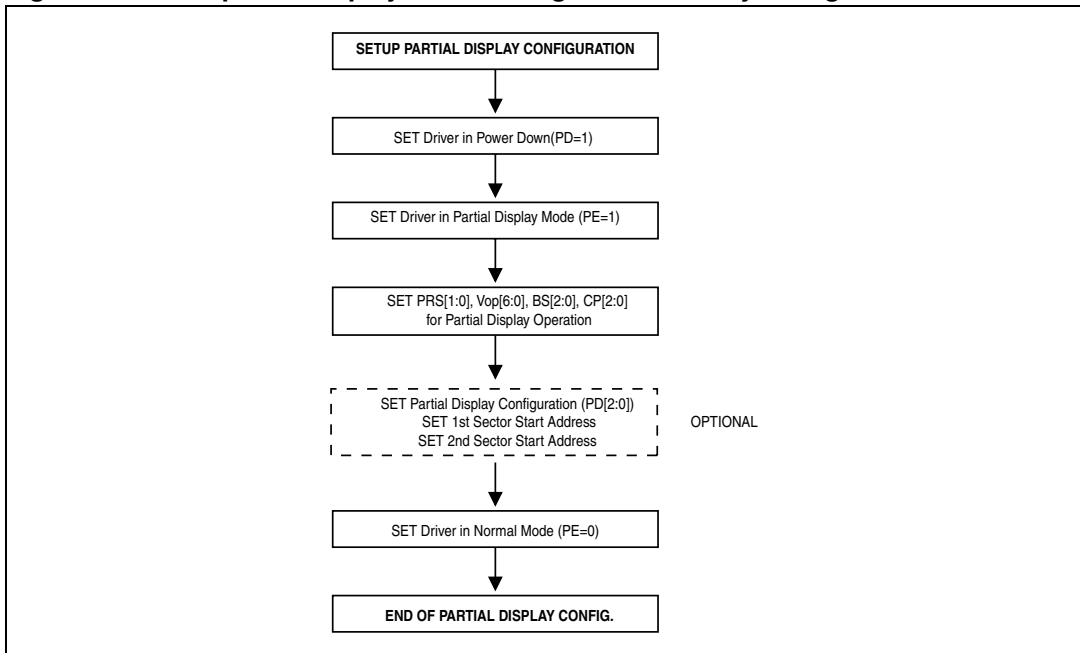

Figure 46. Data RAM to display mapping

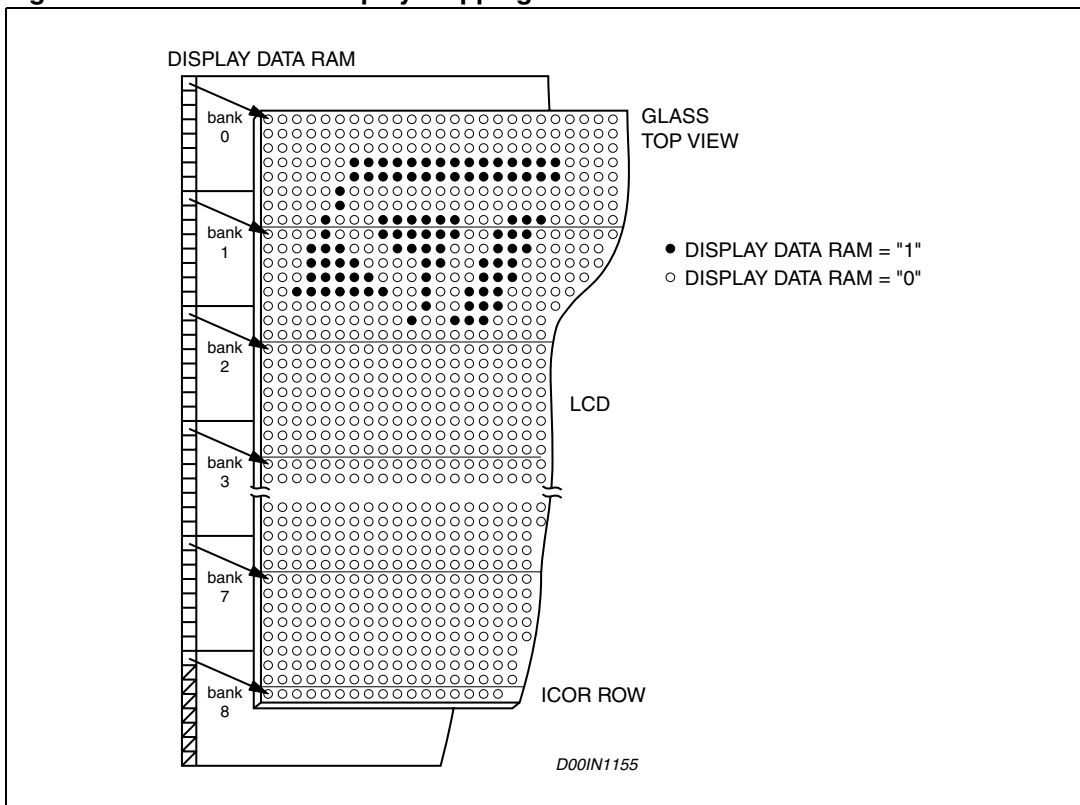

Table 24. Pin configuration

Test numbers	Pin configuration
TEST_1 TEST_2 TEST_3 TEST_4	OPEN
TEST_5 TEST_6 TEST_7 TEST_8 TEST_9 TEST_10	GND
TEST_11 TEST_12 TEST_13 TEST_14	GND

6 Electrical characteristics

6.1 Absolute maximum ratings

Table 25. Absolute maximum ratings

Symbol	Parameter	Value	Unit
V_{DD1}	Supply voltage range	- 0.5 to + 5	V
V_{DD2}	Supply voltage range	- 0.5 to + 7	V
V_{LCD}	LCD Supply Voltage Range	- 0.5 to + 15	V
I_{SS}	Supply current	- 50 to +50	mA
V_i	Input Voltage (all input pads)	-0.5 to $V_{DD2} + 0.5$	V
I_{in}	DC Input Current	- 10 to + 10	mA
I_{out}	DC Output Current	- 10 to + 10	mA
P_{tot}	Total Power Dissipation ($T_j = 85^\circ\text{C}$)	300	mW
P_o	Power Dissipation per Output	30	mW
T_j	Operating Junction Temperature ⁽¹⁾	-20 to + 120	°C
T_{stg}	Storage Temperature	- 65 to 150	°C

1. Device behavior and characterization are measured over this temperature range during internal qualification of the product. During production testing, however, device performance is measured at a fixed ambient temperature, typically 25°C.

6.2 DC operation

V_{DD1} = 1.7 to 3.6 V; V_{DD2} = 1.75 to 4.2V; V_{SS1,2} = 0V; V_{LCD} = 4.5 to 14.5 V;
T_{amb} = 25°C; unless otherwise specified.

Table 26. Electrical characteristics DC operation

Symbol	Parameter	Test Condition	Min.	Typ.	Max.	Unit
Supply voltages						
V _{DD1}	Supply voltage ⁽¹⁾		1.7		3.6	V
V _{DD2}	Supply voltage	LCD voltage internally generated	1.75		4.2	V
V _{LCDIN}	LCD supply voltage	LCD voltage supplied externally	4.5		14.5	V
V _{LCDOUT}	LCD supply voltage	Internally generated ⁽²⁾ ;	4.5		14.5	V
I(V _{DD1})	Supply current	V _{DD1} = 2.8V; V _{LCD} = 10V; f _{sclk} = 0 ⁽³⁾	15	20	40	μA
		V _{DD1} = 2.8V; V _{LCD} = 10V; f _{sclk} = 1Mhz; (1) (3); OSC_IN=GND; parallel port		120	200	μA
I(V _{DD2})	Voltage generator supply current	with V _{OP} = 0 and PRS = [0:0] with external V _{LCD} ⁽⁴⁾			1	μA
		V _{DD2} = 2.8V;V _{LCD} =10V; f _{sclk} = 0; no display load; 5x charge pump (5) (3) (6)	10		40	μA
I(V _{DD1,2})	Total supply current	V _{DD1} ,V _{DD2} = 2.8V; V _{LCD} = 10V; 5x charge pump; f _{sclk} = 0; no display load (5) (3) (6)	25		80	μA
		Power down Mode with internal or External V _{LCD} ⁽⁷⁾		3	10	μA
I(V _{LDCIN})	External LCD supply voltage current	V _{DD} =2.8V; V _{LCD} =10V;no display load; f _{sclk} = 0 (3)	5	10	15	μA
Logic outputs						
V _{OH}	High logic level output voltage	I _{OH} =-500μA	0.8V _{DD1}		V _{DD1}	V
V _{OL}	Low logic level output voltage	I _{OL} =500μA	V _{SS}		0.2V _{DD1}	V

Table 26. Electrical characteristics DC operation

Symbol	Parameter	Test Condition	Min.	Typ.	Max.	Unit
Logic inputs						
V _{IL}	Logic LOW voltage level		V _{SS}		0.3V _{DD1}	V
V _{IH}	Logic HIGH voltage level		0.7V _{DD1}		V _{DD2}	V
I _{in}	Input current	V _{in} = V _{SS1} or V _{DD1}	-1		1	μA
logic inputs/outputs						
V _{IL}	Logic LOW voltage level		V _{SS}		0.3V _{DD1}	V
V _{IH}	Logic HIGH Voltage Level		0.7V _{DD1}		V _{DD1} +0.5V	V
Column and row driver						
R _{row}	ROW output resistance	V _{LCD} = 10V;		3K	5K	kohm
R _{col}	Column output resistance	V _{LCD} = 10V;		5K	10K	kohm
V _{col}	Column Bias voltage accuracy	No load	-50		+50	mV
V _{row}	Row Bias voltage accuracy		-50		+50	mV
LCD supply voltage						
V _{LCD}	LCD supply voltage accuracy; internally generated	V _{DD} = 2.8V; V _{LCD} = 10V; f _{sclk} =0; no display load ⁽⁵⁾⁽³⁾⁽⁶⁾⁽⁸⁾ ⁽⁸⁾ VOP = 61h, PRS = 2hex	-2.2		2.2	%
TC0	Temperature coefficient			-0.0·10 ⁻³		1/°C
TC1				-0.35·10 ⁻³		1/°C
TC2				-0.7·10 ⁻³		1/°C
TC3				-1.05·10 ⁻³		1/°C
TC4				-1.4 ·10 ⁻³		1/°C
TC5				-1.75·10 ⁻³		1/°C
TC6				-2.1·10 ⁻³		1/°C
TC7				-2.3·10 ⁻³		1/°C

1. Data Byte Writing Mode V_{DD1} ≧ V_{DD2}
2. The maximum possible V_{LCD} voltage that can be generated is dependent on voltage, temperature and (display) load.
3. When f_{sclk} = 0 there is no interface clock.
4. External V_{LCD}, the display load current is not transmitted to I_{DD}
5. Internal clock
6. Tolerance depends on the temperature; (typically zero at T_{amb} = 27°C), maximum tolerance values are measured at the temperature range limit.
7. Power-down mode. During power-down all static currents are switched-off.
8. For TC0 to TC7

6.3 AC operation

VDD1 = 1.7 to 3.6V; VDD2 = 1.75 to 4.2V; Vss1,2 = 0V; VLCD = 4.5 to 14.5V; Tamb = 25°C; unless otherwise specified.

Table 27. AC operation

Symbol	Parameter	Test condition	Min.	Typ.	Max.	Unit
Internal oscillator (Figure 47)						
F _{OSC}	Internal oscillator frequency	V _{DD} = 2.8V;	61	72	83	kHz
F _{EXT}	External oscillator frequency		20		100	kHz
F _{FRAME}	Frame frequency	fosc or fext = 72 kHz ⁽¹⁾		75		Hz
T _w (RES)	$\overline{\text{RES}}$ LOW pulse width		5			μs
	Reset pulse rejection				1	μs
T _{LOGIC} (RES)	Internal logic reset time				5	μs
T _{VDD}	V _{DD1} vs. V _{DD2} delay		0			μs
I²C Bus interface⁽⁴⁾ (Figure 48)						
F _{SCL}	SCL clock frequency	Fast Mode	DC		400	kHz
		High Speed Mode; Cb=100pF (max); V _{DD1} =2	DC		3.4	MHz
		High Speed Mode; Cb=400pF (max); V _{DD1} =2	DC		1.7	MHz
		Fast Mode; V _{DD1} =1.7V			400	KHz
T _{SU;STA}	Set-up time (repeated) START condition	Cb=100pF ^{(2) (3)}	160			ns
T _{HD;STA}	Hold time (repeated) START condition	Cb=100pF ^{(2) (3)}	160			ns
T _{LOW}	LOW period of the SCLH clock	Cb=100pF ^{(2) (3)}	160			ns
T _{HIGH}	HIGH period of the SCLH clock	Cb=100pF ^{(2) (3)}	60			ns
T _{SU;DAT}	Data set-up time	Cb=100pF ^{(2) (3)}	10			ns
T _{HD;DAT}	Data hold time	Cb=100pF ^{(2) (3)}	40			ns
T _{r;CL}	Rise time of SCLH signal	Cb=100pF ^{(2) (3)}	10			ns
T _{rCL1}	Rise time of SCLH signal after a repeated START condition and after an acknowledge bit	Cb=100pF ^{(2) (3)}	10			ns
T _{fCL}	Fall time of SCLH signal	Cb=100pF ^{(2) (3)}	10			ns

Table 27. AC operation (continued)

Symbol	Parameter	Test condition	Min.	Typ.	Max.	Unit
T _{rDA}	Rise time of SDAH signal	Cb=100pF ^{(2) (3) (4)}	10			ns
T _{fDA}	Fall time of SDAH signal	Cb=100pF ^{(2) (3) (4)}	10		80	ns
T _{rDA}	Rise time of SDAH signal	Cb=400pF ^{(2) (3) (4)}	20			ns
T _{fDA}	Fall time of SDAH signal	Cb=400pF ^{(2) (3) (4)}	20		160	ns
T _{SU;STO}	Set-up time for STOP condition	Cb=100pF ^{(2) (3)}	160			ns
C _b	Capacitive load for SDAH and SCLH		100		400	pF
C _b	Capacitive load for SDAH + SDA line and SCLH + SCL line				400	pF
Parallel interface (Figure 49, Figure 50)						
T _{CY(EN)}	Enable Cycle Time	V _{DD1} = 1.7V; Write- ^{(2) (5)}	150			ns
T _{W(EN)}	Enable Pulse width		60			ns
T _{SU(A)}	Address Set-up Time		30			ns
T _{H(A)}	Address Hold Time		40			ns
T _{SU(D)}	Data Set-Up Time		30			ns
T _{H(D)}	Data Hold Time		30			ns
T _{SU(D)}	Data Set-Up Time in read Mode				100	ns
T _{HU(D)}	Data Hold Time In Read mode		100			ns

Table 27. AC operation (continued)

Symbol	Parameter	Test condition	Min.	Typ.	Max.	Unit	
Serial interface (Figure 51)							
T _{CYC}	Clock Cycle SCLK	V _{DD1} = 1.7V; Write ^{(2) (5)}	150			ns	
T _{PWH1}	SCLK pulse width HIGH		60			ns	
T _{PWL1}	SCLK Pulse width LOW		60			ns	
T _{S2}	\overline{SCE} setup time		30			ns	
T _{H2}	\overline{SCE} hold time		50			ns	
T _{PWH2}	\overline{SCE} minimum high time		50			ns	
T _{S3}	SD/ \overline{C} setup time		30			ns	
T _{H3}	SD/ \overline{C} hold time		40			ns	
T _{S4}	SDIN setup time		30			ns	
T _{H4}	SDIN hold time		40			ns	
T _{S5}	SOUT Access Time					100	ns
T _{H5}	SOUT Disable Time vs. SCLK					100	ns
T _{H6}	SOUT Disable Time vs. SCE					100	ns

1. frame = $\frac{10s}{96f}$
2. All timing values are valid within the operating supply voltage and ambient temperature ranges and referenced to V_{IL} and V_{IH} with an input voltage swing of V_{SS} to V_{DD}
3. C_b is the capacitive load for each bus line.
4. For bus line loads C_b between 100 and 400pF the timing parameters must be linearly interpolated
5. C_{VLCD} is the filtering Capacitor on VLCDOUTT_{rise} and T_{fall} (30%-70%) = 10 ns

Figure 47. RESET timing diagram

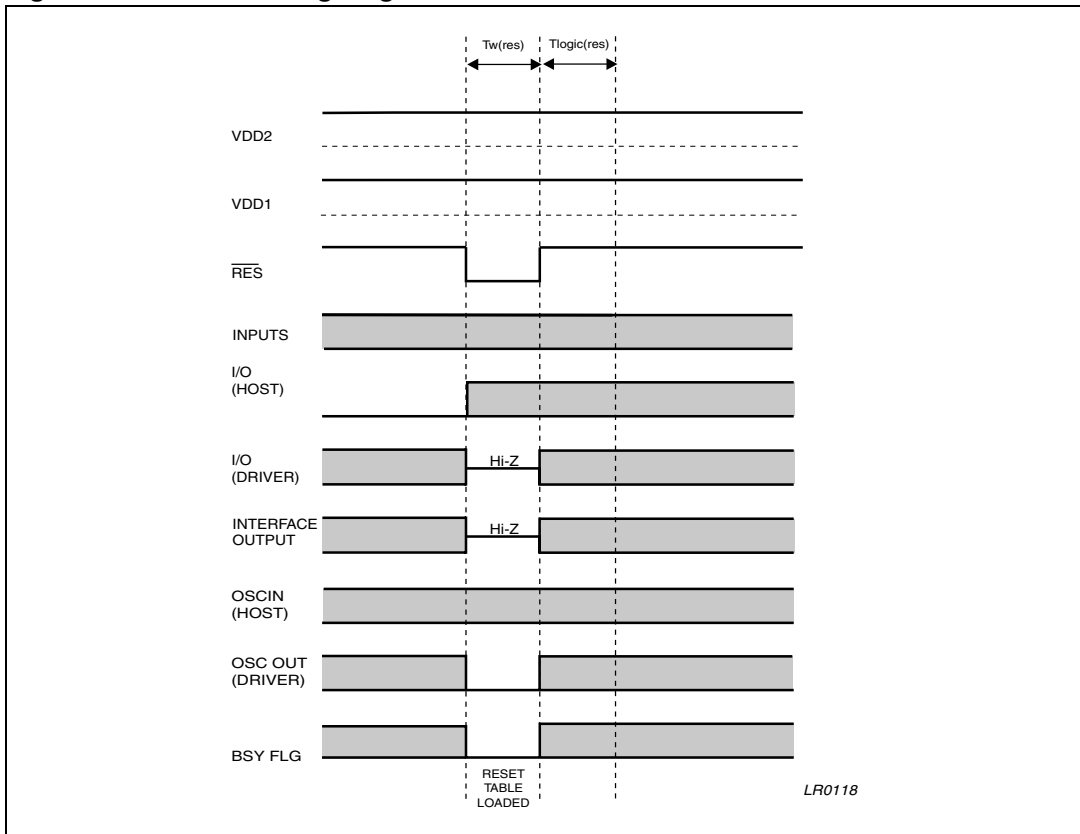

Figure 48. I²C-bus timings

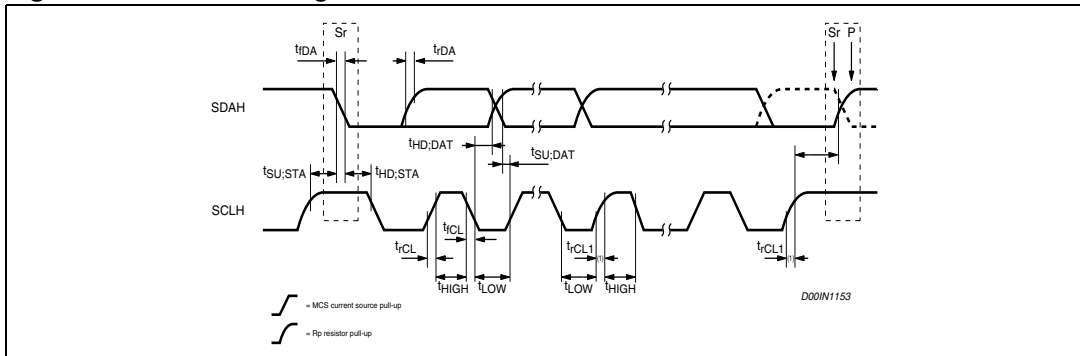

Figure 49. Parallel interface write timing

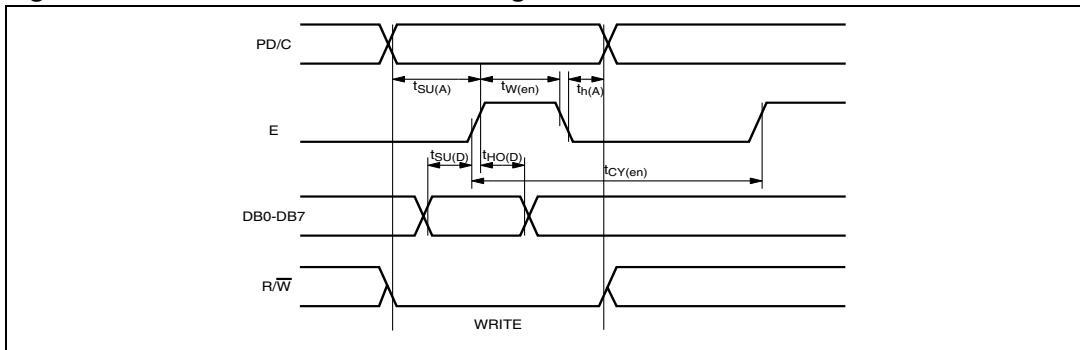

Figure 50. Parallel interface read timing

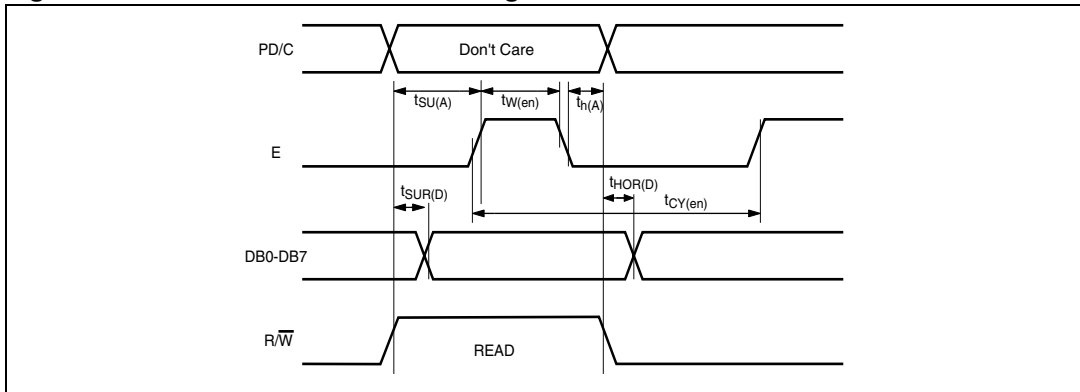
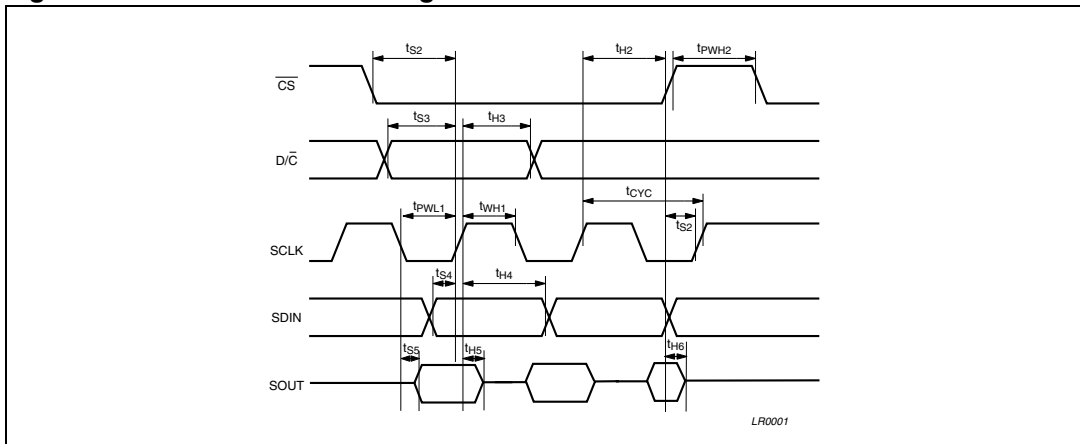

Figure 51. Serial interface timing



7 Pad coordinates

See [Table 28: Pad coordinates](#) and [Table 29: Alignment marks coordinates](#).

Table 28. Pad coordinates

Name	Pad	X (μm)	Y(μm)
C0	1	-3275.0	-946.5
C1	2	-3225.0	-946.5
C2	3	-3175.0	-946.5
C3	4	-3125.0	-946.5
C4	5	-3075.0	-946.5
C5	6	-3025.0	-946.5
C6	7	-2975.0	-946.5
C7	8	-2925.0	-946.5
C8	9	-2875.0	-946.5
C9	10	-2825.0	-946.5
C10	11	-2775.0	-946.5
C11	12	-2725.0	-946.5
C12	13	-2675.0	-946.5
C13	14	-2625.0	-946.5
C14	15	-2575.0	-946.5
C15	16	-2525.0	-946.5
C16	17	-2475.0	-946.5
C17	18	-2425.0	-946.5
C18	19	-2375.0	-946.5
C19	20	-2325.0	-946.5
C20	21	-2275.0	-946.5
C21	22	-2225.0	-946.5
C22	23	-2175.0	-946.5
C23	24	-2125.0	-946.5
C24	25	-2075.0	-946.5
C25	26	-2025.0	-946.5
C26	27	-1975.0	-946.5
C27	28	-1925.0	-946.5
C28	29	-1875.0	-946.5
C29	30	-1825.0	-946.5
C30	31	-1775.0	-946.5
C31	32	-1725.0	-946.5
C32	33	-1675.0	-946.5
C33	34	-1625.0	-946.5

Name	Pad	X (μm)	Y(μm)
C34	35	-1575.0	-946.5
C35	36	-1525.0	-946.5
C36	37	-1475.0	-946.5
C37	38	-1425.0	-946.5
C38	39	-1375.0	-946.5
C39	40	-1325.0	-946.5
C40	41	-1275.0	-946.5
C41	42	-1225.0	-946.5
C42	43	-1175.0	-946.5
C43	44	-1125.0	-946.5
C44	45	-1075.0	-946.5
C45	46	-1025.0	-946.5
C46	47	-975.0	-946.5
C47	48	-925.0	-946.5
C48	49	-875.0	-946.5
C49	50	-825.0	-946.5
C50	51	-775.0	-946.5
C51	52	-725.0	-946.5
C52	53	-675.0	-946.5
C53	54	-625.0	-946.5
C54	55	-575.0	-946.5
C55	56	-525.0	-946.5
C56	57	-475.0	-946.5
C57	58	-425.0	-946.5
C58	59	-375.0	-946.5
C59	60	-325.0	-946.5
C60	61	-275.0	-946.5
C61	62	-225.0	-946.5
C62	63	-175.0	-946.5
C63	64	-125.0	-946.5
C64	65	+125.0	-946.5
C65	66	+175.0	-946.5
C66	67	+225.0	-946.5
C67	68	+275.0	-946.5

Table 28. Pad coordinates (continued)

Name	Pad	X (μm)	Y(μm)
C68	69	+325.0	-946.5
C69	70	+375.0	-946.5
C70	71	+425.0	-946.5
C71	72	+475.0	-946.5
C72	73	+525.0	-946.5
C73	74	+575.0	-946.5
C74	75	+625.0	-946.5
C75	76	+675.0	-946.5
C76	77	+725.0	-946.5
C77	78	+775.0	-946.5
C78	79	+825.0	-946.5
C79	80	+875.0	-946.5
C80	81	+925.0	-946.5
C81	82	+975.0	-946.5
C82	83	+1025.0	-946.5
C83	84	+1075.0	-946.5
C84	85	+1125.0	-946.5
C85	86	+1175.0	-946.5
C86	87	+1225.0	-946.5
C87	88	+1275.0	-946.5
C88	89	+1325.0	-946.5
C89	90	+1375.0	-946.5
C90	91	+1425.0	-946.5
C91	92	+1475.0	-946.5
C92	93	+1525.0	-946.5
C93	94	+1575.0	-946.5
C94	95	+1625.0	-946.5
C95	96	+1675.0	-946.5
C96	97	+1725.0	-946.5
C97	98	+1775.0	-946.5
C98	99	+1825.0	-946.5
C99	100	+1875.0	-946.5
C100	101	+1925.0	-946.5
C101	102	+1975.0	-946.5
C102	103	+2025.0	-946.5

Name	Pad	X (μm)	Y(μm)
C103	104	+2075.0	-946.5
C104	105	+2125.0	-946.5
C105	106	+2175.0	-946.5
C106	107	+2225.0	-946.5
C107	108	+2275.0	-946.5
C108	109	+2325.0	-946.5
C109	110	+2375.0	-946.5
C110	111	+2425.0	-946.5
C111	112	+2475.0	-946.5
C112	113	+2525.0	-946.5
C113	114	+2575.0	-946.5
C114	115	+2625.0	-946.5
C115	116	+2675.0	-946.5
C116	117	+2725.0	-946.5
C117	118	+2775.0	-946.5
C118	119	+2825.0	-946.5
C119	120	+2875.0	-946.5
C120	121	+2925.0	-946.5
C121	122	+2975.0	-946.5
C122	123	+3025.0	-946.5
C123	124	+3075.0	-946.5
C124	125	+3125.0	-946.5
C125	126	+3175.0	-946.5
C126	127	+3225.0	-946.5
C127	128	+3275.0	-946.5
R40	129	+3571.5	-875.0
R41	130	+3571.5	-825.0
R42	131	+3571.5	-775.0
R43	132	+3571.5	-725.0
R44	133	+3571.5	-675.0
R45	134	+3571.5	-625.0
R46	135	+3571.5	-575.0
R47	136	+3571.5	-525.0
R48	137	+3571.5	-475.0
R49	138	+3571.5	-425.0

Table 28. Pad coordinates (continued)

Name	Pad	X (μm)	Y(μm)
R50	139	+3571.5	-375.0
R51	140	+3571.5	-325.0
R52	141	+3571.5	-275.0
R53	142	+3571.5	-225.0
R54	143	+3571.5	-175.0
R55	144	+3571.5	-125.0
R56	145	+3571.5	-75.0
R57	146	+3571.5	-25.0
R58	147	+3571.5	+25.0
R59	148	+3571.5	+75.0
R60	149	+3571.5	+125.0
R61	150	+3571.5	+175.0
R62	151	+3571.5	+225.0
R63	152	+3571.5	+275.0
R64	153	+3571.5	+325.0
R65	154	+3571.5	+375.0
R66	155	+3571.5	+425.0
R67	156	+3571.5	+475.0
R68	157	+3571.5	+525.0
R69	158	+3571.5	+575.0
R70	159	+3571.5	+625.0
R71	160	+3571.5	+675.0
R72	161	+3571.5	+725.0
R73	162	+3571.5	+775.0
R74	163	+3571.5	+825.0
R75	164	+3571.5	+875.0
R76	165	+3275.0	+946.5
R77	166	+3225.0	+946.5
R78	167	+3175.0	+946.5
R79	168	+3125.0	+946.5
R80/ICON	169	+3075.0	+946.5
TEST_1	170	+2825.0	+946.5
TEST_2	171	+2775.0	+946.5
TEST_3	172	+2725.0	+946.5

Name	Pad	X (μm)	Y(μm)
TEST_4	173	+2675.0	+946.5
TEST_5	174	+2625.0	+946.5
TEST_6	175	+2575.0	+946.5
TEST_7	176	+2525.0	+946.5
TEST_8	177	+2475.0	+946.5
TEST_9	178	+2425.0	+946.5
TEST_10	179	+2375.0	+946.5
VSSAUX	180	+2225.0	+946.5
SA1	181	+2175.0	+946.5
SA0	182	+2125.0	+946.5
EXT	183	+2075.0	+946.5
SEL2	184	+2025.0	+946.5
SEL1	185	+1975.0	+946.5
ICON_MODE	186	+1925.0	+946.5
OSC_IN	187	+1875.0	+946.5
VDD1_1	188	+1825.0	+946.5
VDD1_2	189	+1825.0	+839.5
VDD1_3	190	+1775.0	+946.5
VDD1_4	191	+1775.0	+839.5
VDD1_5	192	+1725.0	+946.5
VDD1_6	193	+1725.0	+839.5
VDD1_7	194	+1675.0	+946.5
VDD1_8	195	+1675.0	+839.5
VDD1_9	196	+1625.0	+946.5
VDD1_10	197	+1625.0	+839.5
VDD1_11	198	+1575.0	+946.5
VDD1_12	199	+1575.0	+839.5
VDD2_1	200	+1525.0	+946.5
VDD2_2	201	+1525.0	+839.5
VDD2_3	202	+1475.0	+946.5
VDD2_4	203	+1475.0	+839.5
VDD2_5	204	+1425.0	+946.5
VDD2_6	205	+1425.0	+839.5
VDD2_7	206	+1375.0	+946.5

Table 28. Pad coordinates (continued)

Name	Pad	X (μm)	Y(μm)
VDD2_8	207	+1375.0	+839.5
VDD2_9	208	+1325.0	+946.5
VDD2_10	209	+1325.0	+839.5
VDD2_11	210	+1275.0	+946.5
VDD2_12	211	+1275.0	+839.5
BUSY_FLAG	212	+1125.0	+946.5
SDOUT	213	+975.0	+946.5
SDIN	214	+925.0	+946.5
SD \bar{C}	215	+875.0	+946.5
SCE	216	+825.0	+946.5
SCLK	217	+775.0	+946.5
VSSAUX	218	+625.0	+946.5
R \bar{W}	219	+575.0	+946.5
D7	220	+525.0	+946.5
D6	221	+475.0	+946.5
D5	222	+425.0	+946.5
D4	223	+375.0	+946.5
D3	224	+325.0	+946.5
D2	225	+275.0	+946.5
D1	226	+225.0	+946.5
D0	227	+175.0	+946.5
PD \bar{C}	228	+125.0	+946.5
E	229	+75.0	+946.5
RES	230	-75.0	+946.5
VSSAUX	231	-225.0	+946.5
SDA_OUT	232	-275.0	+946.5
SDA_OUT	233	-325.0	+946.5
SDA_IN	234	-375.0	+946.5
SCL	235	-425.0	+946.5
VSS_1	236	-975.0	+946.5
VSS_2	237	-975.0	+839.5
VSS_3	238	-1025.0	+946.5
VSS_4	239	-1025.0	+839.5
VSS_5	240	-1075.0	+946.5

Name	Pad	X (μm)	Y(μm)
VSS_6	241	-1075.0	+839.5
VSS_7	242	-1125.0	+946.5
VSS_8	243	-1125.0	+839.5
VSS_9	244	-1175.0	+946.5
VSS_10	245	-1175.0	+839.5
VSS_11	246	-1225.0	+946.5
VSS_12	247	-1225.0	+839.5
VSS_13	248	-1275.0	+946.5
VSS_14	249	-1275.0	+839.5
VSS_15	250	-1325.0	+946.5
VSS_16	251	-1325.0	+839.5
VSS_17	252	-1375.0	+946.5
VSS_18	253	-1375.0	+839.5
VSS_19	254	-1425.0	+946.5
VSS_20	255	-1425.0	+839.5
TEST_11	256	-1475.0	+946.5
TEST_12	257	-1525.0	+946.5
TEST_13	258	-1575.0	+946.5
TEST_14	259	-1625.0	+946.5
OSC_OUT	260	-2175.0	+946.5
VLCDIN_1	261	-2325.0	+946.5
VLCDIN_2	262	-2325.0	+839.5
VLCDIN_3	263	-2375.0	+946.5
VLCDIN_4	264	-2375.0	+839.5
VLCDIN_5	265	-2425.0	+946.5
VLCDIN_6	266	-2425.0	+839.5
VLCDIN_7	267	-2475.0	+946.5
VLCDIN_8	268	-2475.0	+839.5
VLCDIN_9	269	-2525.0	+946.5
VLCDIN_10	270	-2525.0	+839.5
VLCDSENSE_1	271	-2575.0	+946.5
VLCDSENSE_2	272	-2575.0	+839.5
VLCDOUT_1	273	-2625.0	+946.5
VLCDOUT_2	274	-2625.0	+839.5

Table 28. Pad coordinates (continued)

Name	Pad	X (μm)	Y(μm)
VLCDOUT_3	275	-2675.0	+946.5
VLCDOUT_4	276	-2675.0	+839.5
VLCDOUT_5	277	-2725.0	+946.5
VLCDOUT_6	278	-2725.0	+839.5
VLCDOUT_7	279	-2775.0	+946.5
VLCDOUT_8	280	-2775.0	+839.5
VLCDOUT_9	281	-2825.0	+946.5
VLCDOUT_10	282	-2825.0	+839.5
R39	283	-3075.0	+946.5
R38	284	-3125.0	+946.5
R37	285	-3175.0	+946.5
R36	286	-3225.0	+946.5
R35	287	-3275.0	+946.5
R34	288	-3571.5	+875.0
R33	289	-3571.5	+825.0
R32	290	-3571.5	+775.0
R31	291	-3571.5	+725.0
R30	292	-3571.5	+675.0
R29	293	-3571.5	+625.0
R28	294	-3571.5	+575.0
R27	295	-3571.5	+525.0
R26	296	-3571.5	+475.0
R25	297	-3571.5	+425.0
R24	298	-3571.5	+375.0
R23	299	-3571.5	+325.0
R22	300	-3571.5	+275.0
R21	301	-3571.5	+225.0
R20	302	-3571.5	+175.0
R19	303	-3571.5	+125.0
R18	304	-3571.5	+75.0
R17	305	-3571.5	+25.0
R16	306	-3571.5	-25.0
R15	307	-3571.5	-75.0

Name	Pad	X (μm)	Y(μm)
R13	309	-3571.5	-175.0
R12	310	-3571.5	-225.0
R11	311	-3571.5	-275.0
R10	312	-3571.5	-325.0
R9	313	-3571.5	-375.0
R8	314	-3571.5	-425.0
R7	315	-3571.5	-475.0
R6	316	-3571.5	-525.0
R5	317	-3571.5	-575.0
R4	318	-3571.5	-625.0
R3	319	-3571.5	-675.0
R2	320	-3571.5	-725.0
R1	321	-3571.5	-775.0
R0	322	-3571.5	-825.0
ICON	323	-3571.5	-875.0

Table 29. Alignment marks coordinates

X	Y	Marks
-3574.5	-949.5	mark1
+3574.5	-949.5	mark2
-2250	+949.5	mark3
+1200	+949.5	mark4

Figure 52. Alignment marks dimensions

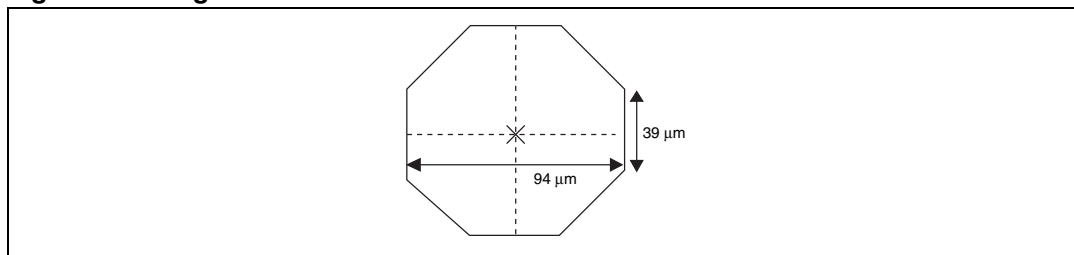

8 Mechanical data

Table 30. Bumps

	Bump number	Dimensions
Bumps on single row size	1-187 212-235 256-260 283-323	30µm x 98 µm x 17.5
Bumps on two rows size	188-211 236-255 261-282	30µm x 87 µm x 17.5
Pad size	1-323	43µm x 107µm
Pad pitch	1-323	50µm
Spacing between bumps	1-323	20µm

Table 31. Die mechanical dimensions

Die size	2.07mm x 7.32mm
Wafers thickness	500µm

Figure 53. Die orientation in tray

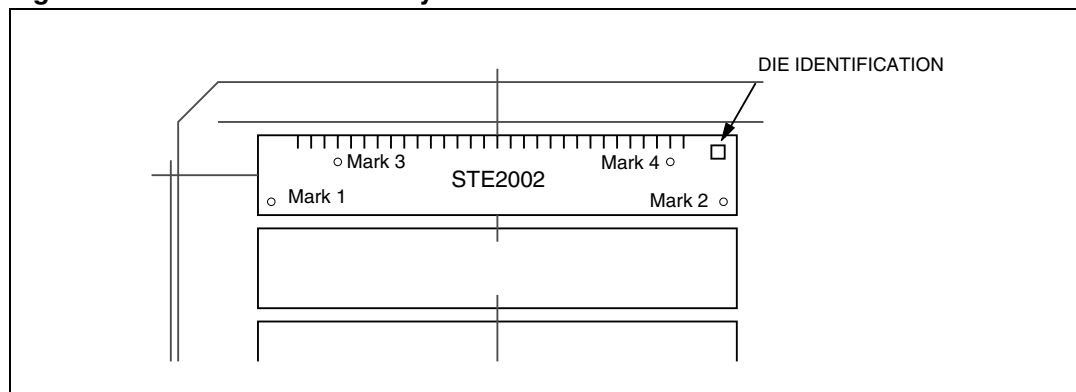
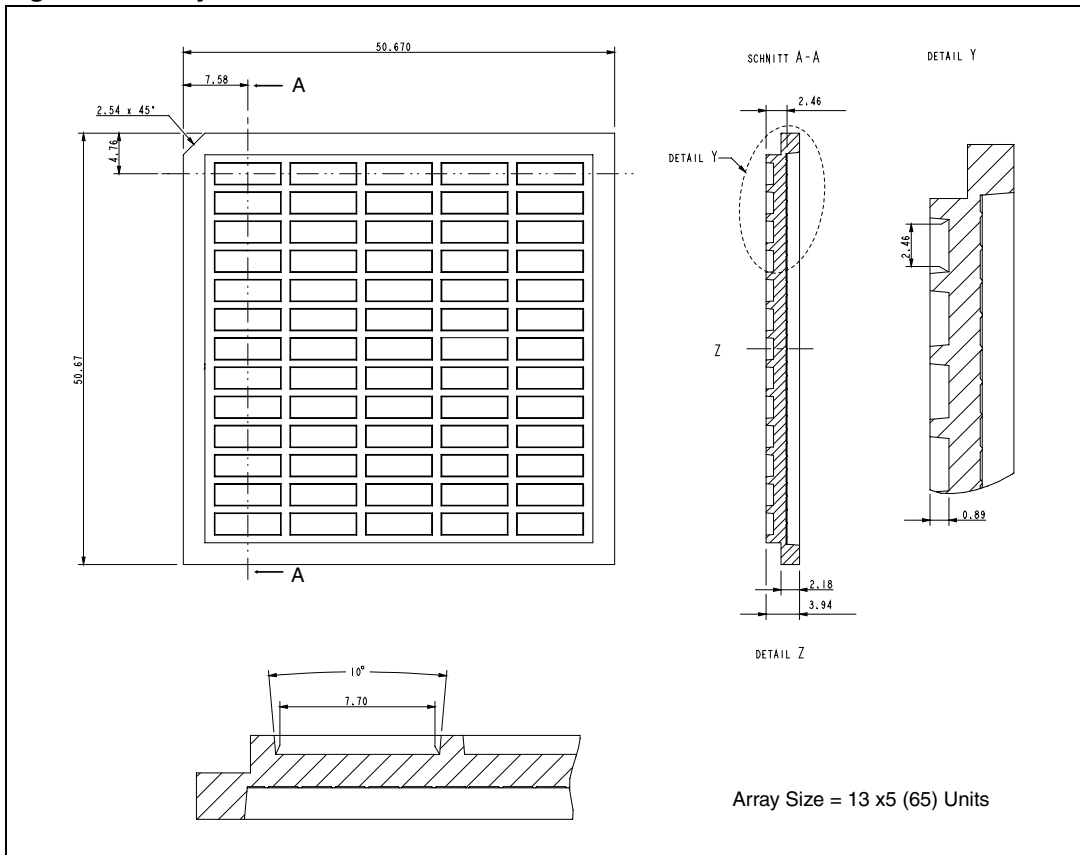

Figure 54. Tray information



9 Ordering information

Table 32. Order codes

Part numbers	Type
STE2002DIE1	Bumped wafers
STE2002DIE2	Bumped dice on waffle pack

10 Revision history

Table 33. Document revision history

Date	Revision	Changes
15-Sep-2002	1	Initial release.
15-Sep- 2005	2	Updated supply current values, LCD supply voltage accuracy, Internal Oscillator frequency range
12-Dec-2006	3	Reviewed the Junction operating temperature range in Table 25: Absolute maximum ratings and added a footnote.

Please Read Carefully:

Information in this document is provided solely in connection with ST products. STMicroelectronics NV and its subsidiaries ("ST") reserve the right to make changes, corrections, modifications or improvements, to this document, and the products and services described herein at any time, without notice.

All ST products are sold pursuant to ST's terms and conditions of sale.

Purchasers are solely responsible for the choice, selection and use of the ST products and services described herein, and ST assumes no liability whatsoever relating to the choice, selection or use of the ST products and services described herein.

No license, express or implied, by estoppel or otherwise, to any intellectual property rights is granted under this document. If any part of this document refers to any third party products or services it shall not be deemed a license grant by ST for the use of such third party products or services, or any intellectual property contained therein or considered as a warranty covering the use in any manner whatsoever of such third party products or services or any intellectual property contained therein.

UNLESS OTHERWISE SET FORTH IN ST'S TERMS AND CONDITIONS OF SALE ST DISCLAIMS ANY EXPRESS OR IMPLIED WARRANTY WITH RESPECT TO THE USE AND/OR SALE OF ST PRODUCTS INCLUDING WITHOUT LIMITATION IMPLIED WARRANTIES OF MERCHANTABILITY, FITNESS FOR A PARTICULAR PURPOSE (AND THEIR EQUIVALENTS UNDER THE LAWS OF ANY JURISDICTION), OR INFRINGEMENT OF ANY PATENT, COPYRIGHT OR OTHER INTELLECTUAL PROPERTY RIGHT.

UNLESS EXPRESSLY APPROVED IN WRITING BY AN AUTHORIZED ST REPRESENTATIVE, ST PRODUCTS ARE NOT RECOMMENDED, AUTHORIZED OR WARRANTED FOR USE IN MILITARY, AIR CRAFT, SPACE, LIFE SAVING, OR LIFE SUSTAINING APPLICATIONS, NOR IN PRODUCTS OR SYSTEMS WHERE FAILURE OR MALFUNCTION MAY RESULT IN PERSONAL INJURY, DEATH, OR SEVERE PROPERTY OR ENVIRONMENTAL DAMAGE. ST PRODUCTS WHICH ARE NOT SPECIFIED AS "AUTOMOTIVE GRADE" MAY ONLY BE USED IN AUTOMOTIVE APPLICATIONS AT USER'S OWN RISK.

Resale of ST products with provisions different from the statements and/or technical features set forth in this document shall immediately void any warranty granted by ST for the ST product or service described herein and shall not create or extend in any manner whatsoever, any liability of ST.

ST and the ST logo are trademarks or registered trademarks of ST in various countries.

Information in this document supersedes and replaces all information previously supplied.

The ST logo is a registered trademark of STMicroelectronics. All other names are the property of their respective owners.

© 2006 STMicroelectronics - All rights reserved

STMicroelectronics group of companies

Australia - Belgium - Brazil - Canada - China - Czech Republic - Finland - France - Germany - Hong Kong - India - Israel - Italy - Japan - Malaysia - Malta - Morocco - Singapore - Spain - Sweden - Switzerland - United Kingdom - United States of America

www.st.com

