

Silicon PNP Power Transistors

2SB1317

DESCRIPTION

- With TO-3PL package
- Complement to type 2SD1975
- Wide area of safe operation
- High transition frequency f_T
- Optimum for the output stage of a Hi-Fi audio amplifier

APPLICATIONS

- For high power amplification

PINNING

PIN	DESCRIPTION
1	Emitter
2	Collector;connected to mounting base
3	Base

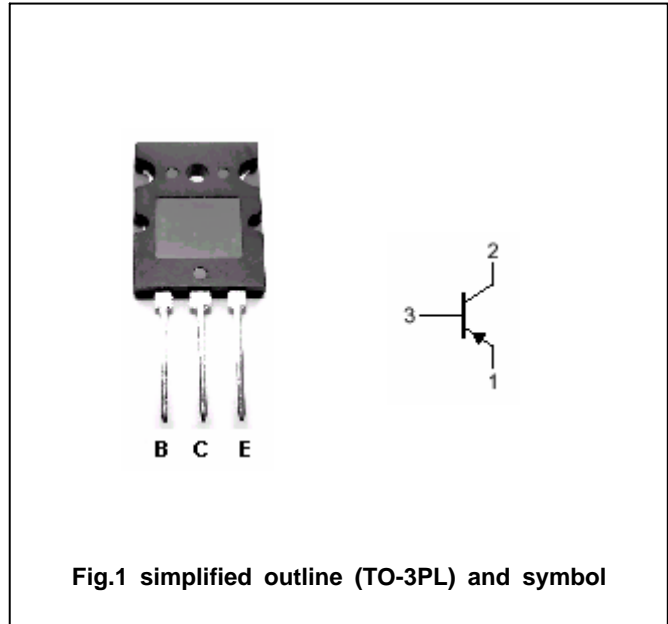

Absolute maximum ratings($T_a=25$)

SYMBOL	PARAMETER	CONDITIONS	VALUE	UNIT
V_{CBO}	Collector-base voltage	Open emitter	-180	V
V_{CEO}	Collector-emitter voltage	Open base	-180	V
V_{EBO}	Emitter-base voltage	Open collector	-5	V
I_C	Collector current		-15	A
I_{CM}	Collector current-peak		-25	A
P_C	Collector power dissipation	$T_a=25$	3.5	W
		$T_C=25$	150	
T_j	Junction temperature		150	
T_{stg}	Storage temperature		-55~150	

Silicon PNP Power Transistors

2SB1317

CHARACTERISTICS

T_j=25 unless otherwise specified

SYMBOL	PARAMETER	CONDITIONS	MIN	TYP.	MAX	UNIT
V _{CEsat}	Collector-emitter saturation voltage	I _C =-10A ; I _B =-1A			-2.5	V
V _{BE}	Base-emitter on voltage	I _C =-8A ; V _{CE} =-5V			-1.8	V
I _{CB0}	Collector cut-off current	V _{CB} =-180V; I _E =0			-50	μ A
I _{EB0}	Emitter cut-off current	V _{EB} =-3V; I _C =0			-50	μ A
h _{FE-1}	DC current gain	I _C =-20mA ; V _{CE} =-5V	20			
h _{FE-2}	DC current gain	I _C =-1A ; V _{CE} =-5V	60		200	
h _{FE-3}	DC current gain	I _C =-8A ; V _{CE} =-5V	20			
f _T	Transition frequency	I _C =-0.5A ; V _{CE} =-5V; f=1MHz		20		MHz
C _{OB}	Collector output capacitance	I _E =0; f=1MHz; V _{CB} =-10V		450		pF

◆ h_{FE-2} classifications

Q	S	P
60-120	80-160	100-200

Silicon PNP Power Transistors

2SB1317

PACKAGE OUTLINE

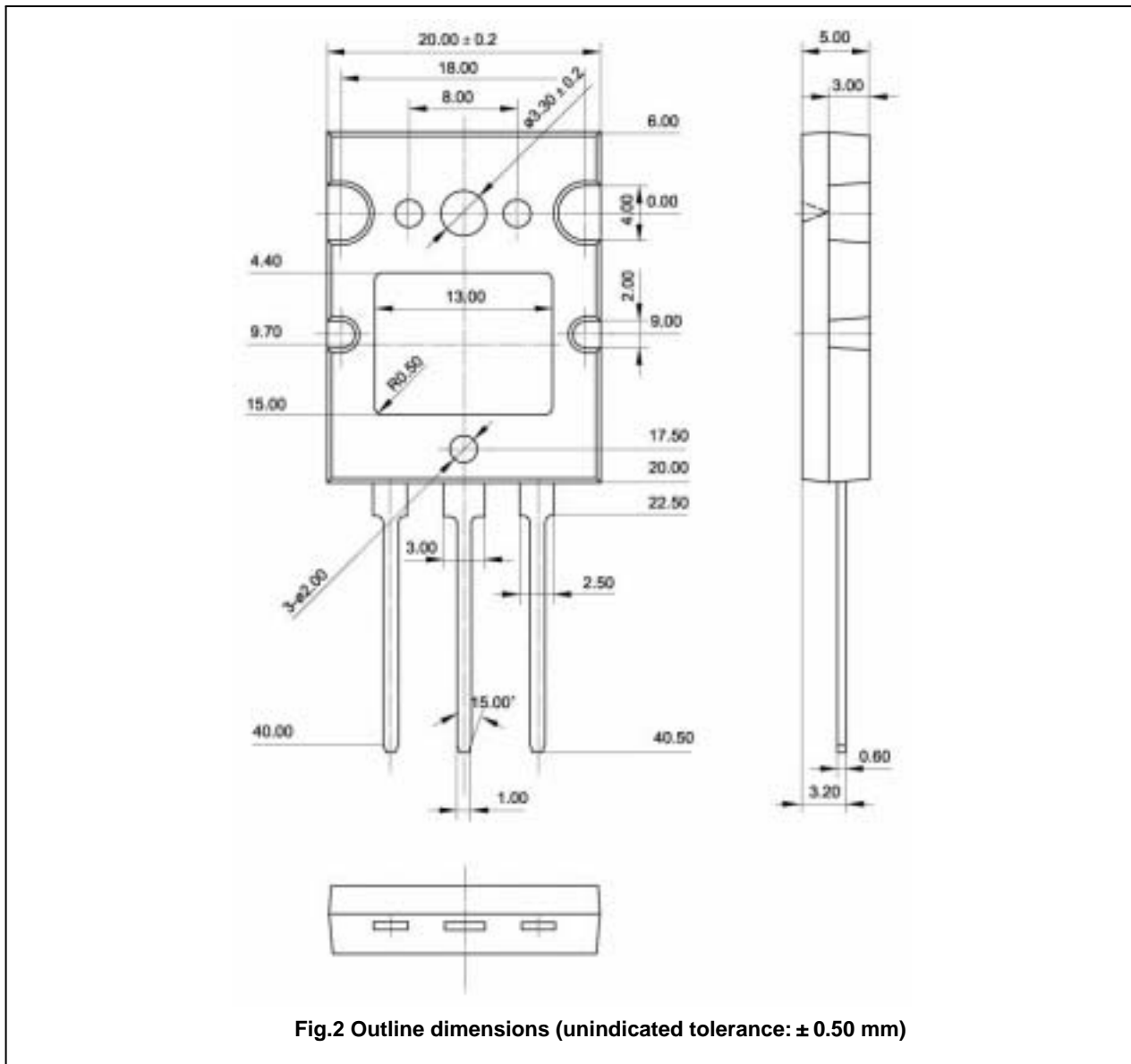

Fig.2 Outline dimensions (unindicated tolerance: ± 0.50 mm)

Silicon PNP Power Transistors

2SB1317

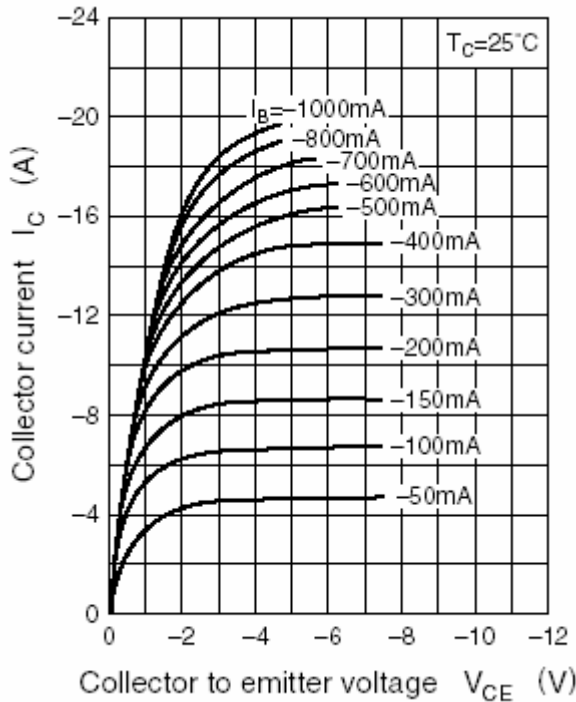

Fig.3 Static Characteristic

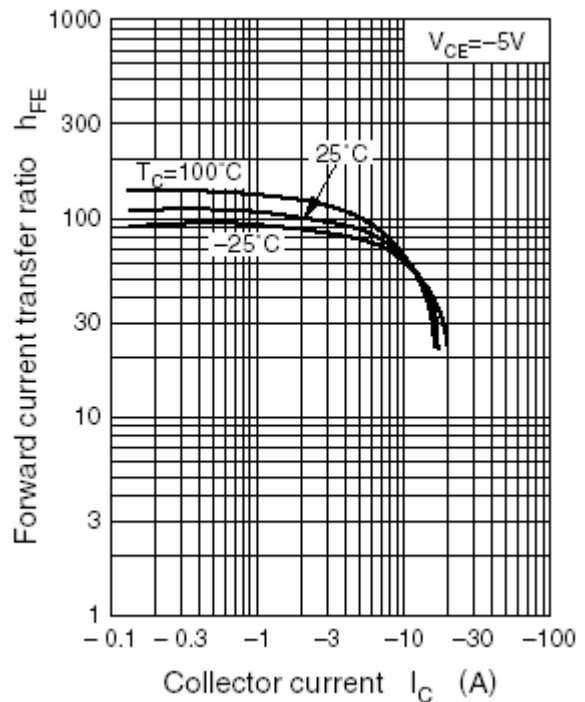

Fig.4 DC current Gain

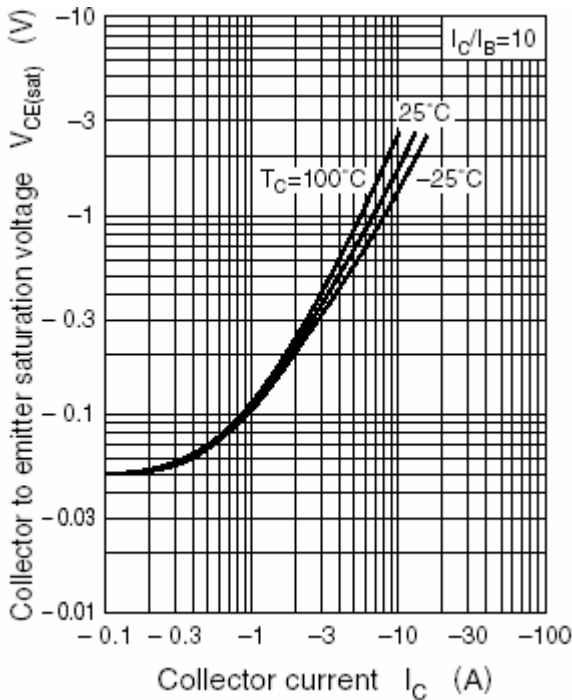

Fig.5 Collector-Emitter Saturation Voltage

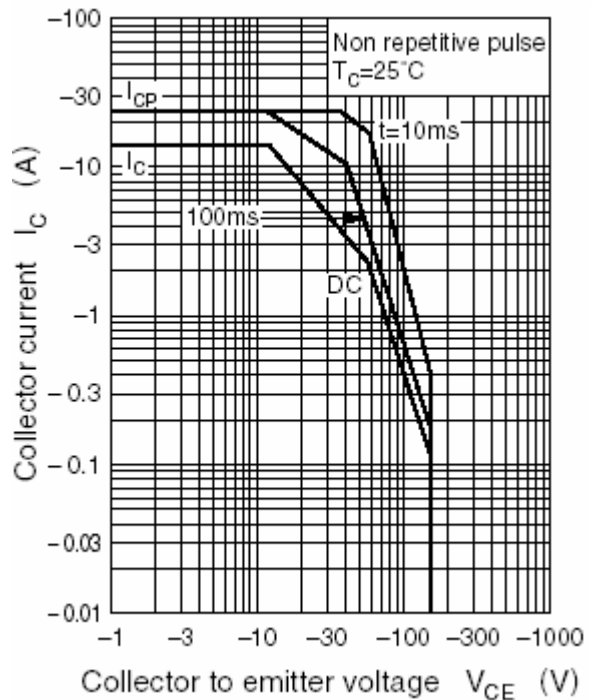

Fig.6 Safe Operating Area