

High Voltage Power Operational Amplifiers

FEATURES

- ◆ HIGH VOLTAGE — 900V ($\pm 450V$)
- ◆ LOW QUIESCENT CURRENT — 1.6mA
- ◆ HIGH OUTPUT CURRENT — 100mA
- ◆ PROGRAMMABLE CURRENT LIMIT

APPLICATIONS

- ◆ HIGH VOLTAGE INSTRUMENTATION
- ◆ PROGRAMMABLE POWER SUPPLIES UP TO $\pm 430V$
- ◆ MASS SPECTROMETERS
- ◆ SEMICONDUCTOR MEASUREMENT EQUIPMENT

DESCRIPTION

The PA95 is a high voltage, MOSFET operational amplifier designed as a low cost solution for driving continuous output currents up to 100mA and pulse currents up to 200mA into capacitive loads. The safe operating area (SOA) has no second breakdown limitations and can be observed for all load types by choosing an appropriate current limiting resistor. The MOSFET output stage is biased AB for linear operation. External compensation provides flexibility in choosing bandwidth and slew rate for the application. APEX's Power SIP package uses a minimum of board space allowing for high density circuit boards. The Power SIP package is electrically isolated. Isolating thermal washers (TW13) are recommended to prevent arcing from pins to heat-sink.

EQUIVALENT SCHEMATIC

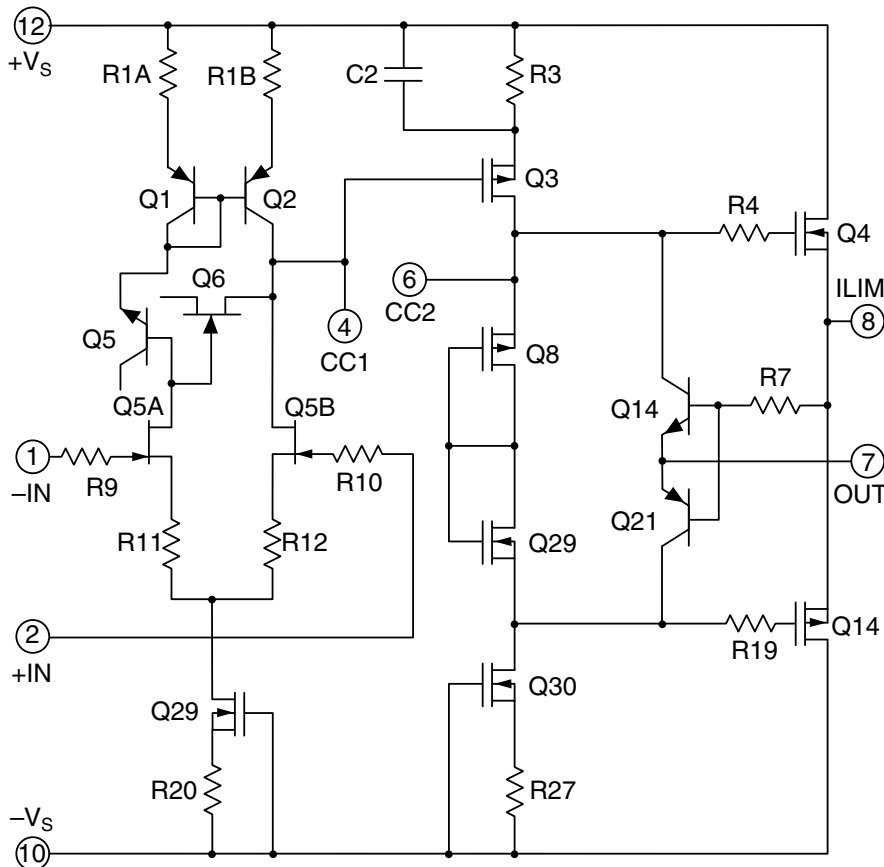

EXTERNAL CONNECTIONS

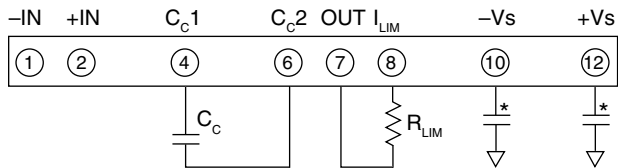

* .01F or greater ceramic power supply bypassing required.



PATENTED

**8-pin SIP
PACKAGE
STYLE DQ**

Formed leads available
See package style EC

1. CHARACTERISTICS AND SPECIFICATIONS

ABSOLUTE MAXIMUM RATINGS

| Parameter | Symbol | Min | Max | Units |
|--|--------|--------|-------|------------------|
| SUPPLY VOLTAGE, $+V_s$ to $-V_s$ | | | 900 | V |
| OUTPUT CURRENT, source, sink, within SOA | | | 200 | mA |
| POWER DISSIPATION, continuous @ $T_c = 25^\circ\text{C}$ | | | 30 | W |
| INPUT VOLTAGE, differential | | -20 | 20 | V |
| INPUT VOLTAGE, common mode (Note 3) | | $-V_s$ | V_s | V |
| TEMPERATURE, pin solder, 10s max. | | | 260 | $^\circ\text{C}$ |
| TEMPERATURE, junction (Note 2) | | | 150 | $^\circ\text{C}$ |
| TEMPERATURE RANGE, storage | | -40 | 85 | $^\circ\text{C}$ |
| OPERATING TEMPERATURE RANGE, case | | -25 | 85 | $^\circ\text{C}$ |

CAUTION The PA95 is constructed from MOSFET transistors. ESD handling procedures must be observed. The exposed substrate contains beryllia (BeO). Do not crush, machine, or subject to temperatures in excess of 850°C to avoid generating toxic fumes.

SPECIFICATIONS

| Parameter | Test Conditions ¹ | Min | Typ | Max | Units |
|------------------------------------|--|------------------|-----------|------|------------------------------|
| INPUT | | | | | |
| OFFSET VOLTAGE, initial | | | 0.5 | 5 | mV |
| OFFSET VOLTAGE vs. temperature | Full temperature range | | 15 | 50 | $\mu\text{V}/^\circ\text{C}$ |
| OFFSET VOLTAGE vs. supply | | | 10 | 25 | $\mu\text{V}/\text{V}$ |
| OFFSET VOLTAGE vs. time | | | 75 | | $\mu\text{V}/\text{kHz}$ |
| BIAS CURRENT, initial | | | 200 | 2000 | pA |
| BIAS CURRENT vs. supply | | | 4 | | pA/V |
| OFFSET CURRENT, initial | | | 50 | 500 | pA |
| INPUT RESISTANCE, DC | | | 10^{11} | | Ω |
| INPUT CAPACITANCE | | | 4 | | pF |
| COMMON MODE VOLTAGE RANGE (Note 3) | $V_s = \pm 250\text{V}$ | $\pm V_s \mp 30$ | | | V |
| COMMON MODE REJECTION, DC | $V_{\text{CM}} = \pm 90\text{V}$ | 80 | 98 | | dB |
| NOISE | 10KHz bandwidth, $R_s = 1\text{k}\Omega$ | | 2 | | $\mu\text{V RMS}$ |

| Parameter | Test Conditions ¹ | Min | Typ | Max | Units |
|---|------------------------------|------------------|------------------|-----------|------------|
| GAIN | | | | | |
| OPEN LOOP @ 15Hz | $R_L = 5K\Omega$ | 94 | 118 | | dB |
| GAIN BANDWIDTH PRODUCT @ 1MHz | $R_L = 5K\Omega$ | | 10 | | MHz |
| POWER BANDWIDTH | $R_L = 5K\Omega$ | | 20 | | kHz |
| PHASE MARGIN, $A_V = 10$ | Full temp range | | 60 | | ° |
| OUTPUT | | | | | |
| VOLTAGE SWING | $I_o = 70mA$ | $\pm V_s \mp 24$ | $\pm V_s \mp 20$ | | V |
| CURRENT, continuous | | 100 | | | mA |
| SLEW RATE, $A_V = 100$ | $C_c = 4.7pF$ | | 30 | | V/ μS |
| SETTLING TIME, to 0.1% | 2V Step | | 1 | | μS |
| RESISTANCE | no load | | 100 | | Ω |
| POWER SUPPLY | | | | | |
| VOLTAGE (Note 5) | | ± 50 | ± 300 | ± 450 | V |
| CURRENT, quiescent | | | 1.6 | 2.2 | mA |
| THERMAL | | | | | |
| RESISTANCE, AC, junction to case (Note 4) | Full temp range, $F > 60Hz$ | | | 2.5 | °C/W |
| RESISTANCE, DC, junction to case | Full temp range, $F < 60Hz$ | | | 4.2 | °C/W |
| RESISTANCE, junction to air | Full temp range | | 30 | | °C/W |
| TEMPERATURE RANGE, case | | -25 | | +85 | °C |

- NOTES: 1. Unless otherwise noted: $T_c = 25^\circ C$, DC input specifications are \pm value given. Power supply voltage is typical rating. $C_c = 4.7pF$.
2. Long term operation at the maximum junction temperature will result in reduced product life. Derate internal power dissipation to achieve high MTTF.
3. Although supply voltages can range up to $\pm 450V$ the input pins cannot swing over this range. The input pins must be at least 30V from either supply rail but not more than 500V from either supply rail. See text for a more complete description of the common mode voltage range.
4. Rating applies if the output current alternates between both output transistors at a rate faster than 60Hz.
5. Derate max supply rating .625 V/°C below 25°C case. No derating needed above 25°C case.

TYPICAL APPLICATION

Piezo positioning may be applied to the focusing of segmented mirror systems. The composite mirror may be composed of hundreds of elements, each requiring focusing under computer control. In such complex systems the PA95 reduces the costs of power supplies and cooling with its advantages of low cost and low quiescent power consumption while increasing circuit density with the SIP package.

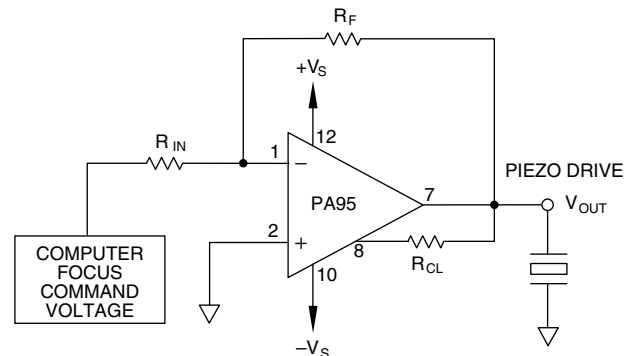

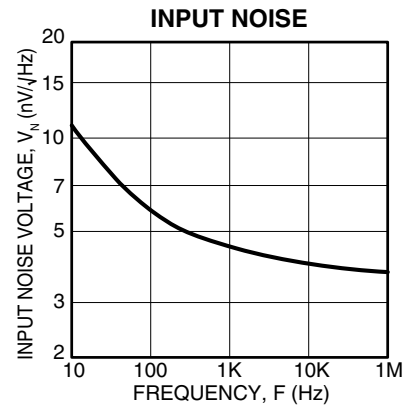
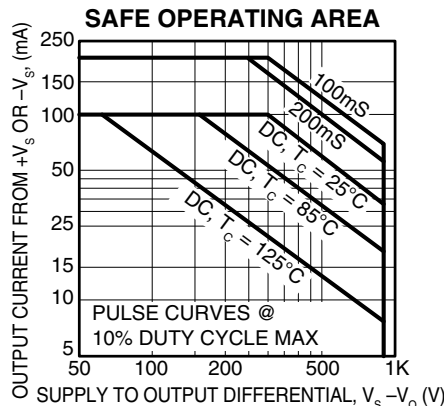
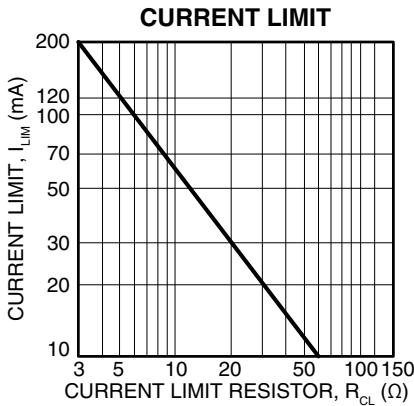
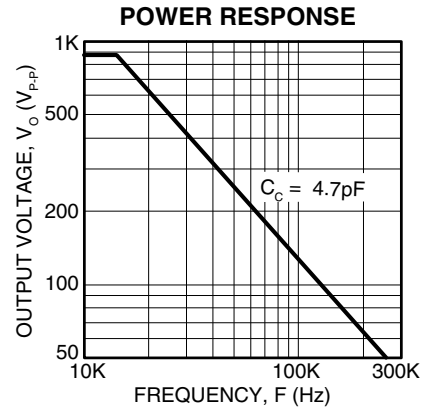
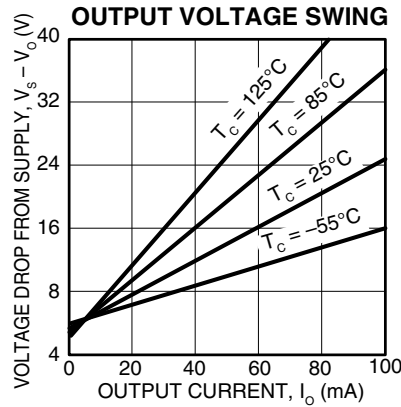
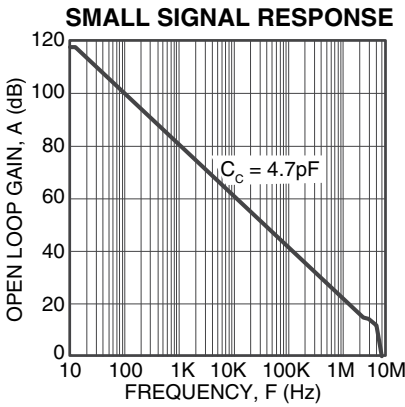
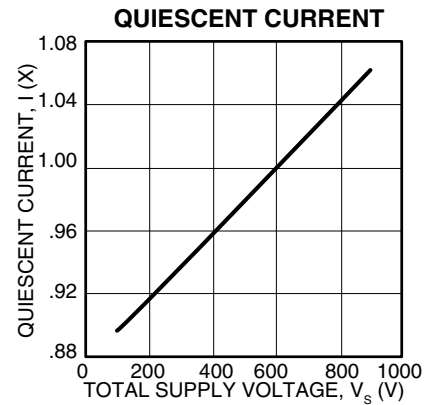
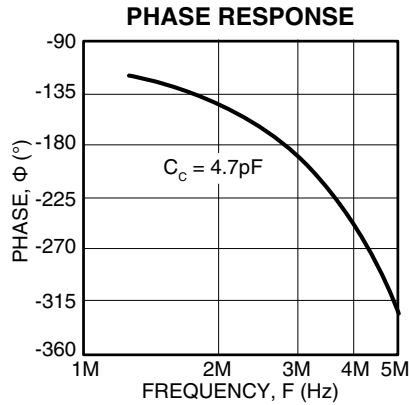
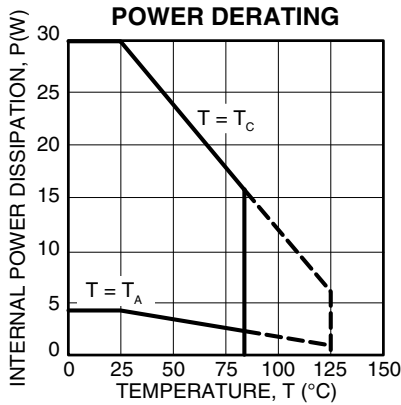

PHASE COMPENSATION

C_c rated for full supply voltage.

$$\frac{\text{GAIN}}{\geq 100} = \frac{C_c}{4.7\text{pF}}$$

$$R_{LIM} = \frac{.7}{I_{LIM}}$$

GENERAL

Please read Application Note 1 "General Operating Considerations" which covers stability, supplies, heat sinking, mounting, current limit, SOA interpretation, and specification interpretation. Visit www.cirrus.com for design tools that help automate tasks such as calculations for stability, internal power dissipation, current limit; heat sink selection; Apex's complete Application Notes library; Technical Seminar Workbook; and Evaluation Kits.

CURRENT LIMIT

For proper operation, the current limit resistor (R_{LIM}) must be connected as shown in the external connection diagram. The minimum value is 3.5 ohm, however for optimum reliability the resistor value should be set as high as possible. The value is calculated as follows; with the maximum practical value of 150 ohms.

$$R_{LIM} = \frac{.7}{I_{LIM}}$$

COMMON MODE INPUT RANGE

Operational amplifiers are usually designed to have a common mode input voltage range that approximates the power supply voltage range. However, to keep the cost as low as possible and still meet the requirements of most applications the common mode input voltage range of the PA95 is restricted. The input pins must always be a least 30V from either supply voltage but never more than 500V. This means that the PA95 cannot be used in applications where the supply voltages are extremely unbalanced. For example, supply voltages of +800V and -100V would not be allowed in an application where the non-inverting pin is grounded because in normal operation both input pins would be at 0V and the difference voltage between the positive supply and the input pins would be 800V. In this kind of application, however, supply voltages +500V and -100V does meet the input common mode voltage range requirements since the maximum difference voltage between the inputs pins and the supply voltage is 500V (the maximum allowed). The output has no such restrictions on its voltage swing. The output can swing within 24V of either supply voltage regardless of value so long as the total supply voltage does not exceed 900V.

INPUT PROTECTION

Although the PA95 can withstand differential input voltages up to $\pm 20V$, additional external protection is recommended. In most applications 1N4148 or 1N914 signal diodes are sufficient (D1, D2 in Figure 1a). In more demanding applications where low leakage or low capacitance are of concern 2N4416 or 2N5457-2N5459 JFETs connected as diodes will be required (Q1, Q2 in Figure 1b). In either case the input differential voltage will be clamped to $\pm 7V$. This is sufficient overdrive to produce maximum power bandwidth. Note that this protection does not automatically protect the amplifier from excessive common mode input voltages.

POWER SUPPLY PROTECTION

Unidirectional zener diode transient suppressors are recommended as protection on the supply pins. The zeners clamp transients to voltages within the power supply rating and also clamp power supply reversals to ground. Whether the zeners are used or not, the system power supply should be evaluated for transient performance including power-on overshoot and power-off polarity reversal as well as line regulation.

Conditions which can cause open circuits or polarity reversals on either power supply rail should be avoided or protected against.

Reversals or opens on the negative supply rail is known to induce input stage failure. Unidirectional transzorbors prevent this, and it is desirable that they be both electrically and physically as close to the amplifier as possible.

FIGURE 1. OVERVOLTAGE PROTECTION

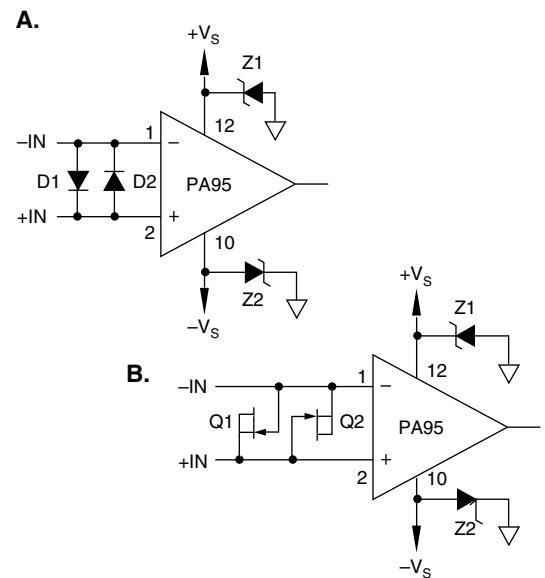

STABILITY

The PA95 is stable at gains of 10 or more with a NPO (COG) compensation capacitor of 4.7pF. The compensation capacitor, Cc, in the external connections diagram must be rated at 1000V working voltage and mounted closely to pins 4 and 6 to prevent spurious oscillation. A compensation capacitor less than 4.7pF is not recommended.

EXTERNAL COMPONENTS

The compensation capacitor Cc must be rated for the total supply voltage. An NPO (COG) capacitor rated a 1kV is recommended.

Of equal importance are the voltage rating and voltage coefficient of the gain setting feedback resistor. Typical voltage ratings of low wattage resistors are 150 to 250V. Up to 500 V can appear across the feedback resistor. High voltage rated resistors can be obtained. However a 1 megohm feedback resistor composed of five 200k resistors in series will produce the proper voltage rating.

CAUTIONS

The operating voltages of the PA95 are potentially lethal. During circuit design develop a functioning circuit at the lowest possible voltages. Clip test leads should be used for "hands off" measurements while troubleshooting.

CONTACTING CIRRUS LOGIC SUPPORT

For all Apex Precision Power product questions and inquiries, call toll free 800-546-2739 in North America.

For inquiries via email, please contact tucson.support@cirrus.com.

International customers can also request support by contacting their local Cirrus Logic Sales Representative.

To find the one nearest to you, go to www.cirrus.com

IMPORTANT NOTICE

Cirrus Logic, Inc. and its subsidiaries ("Cirrus") believe that the information contained in this document is accurate and reliable. However, the information is subject to change without notice and is provided "AS IS" without warranty of any kind (express or implied). Customers are advised to obtain the latest version of relevant information to verify, before placing orders, that information being relied on is current and complete. All products are sold subject to the terms and conditions of sale supplied at the time of order acknowledgment, including those pertaining to warranty, indemnification, and limitation of liability. No responsibility is assumed by Cirrus for the use of this information, including use of this information as the basis for manufacture or sale of any items, or for infringement of patents or other rights of third parties. This document is the property of Cirrus and by furnishing this information, Cirrus grants no license, express or implied under any patents, mask work rights, copyrights, trademarks, trade secrets or other intellectual property rights. Cirrus owns the copyrights associated with the information contained herein and gives consent for copies to be made of the information only for use within your organization with respect to Cirrus integrated circuits or other products of Cirrus. This consent does not extend to other copying such as copying for general distribution, advertising or promotional purposes, or for creating any work for resale.

CERTAIN APPLICATIONS USING SEMICONDUCTOR PRODUCTS MAY INVOLVE POTENTIAL RISKS OF DEATH, PERSONAL INJURY, OR SEVERE PROPERTY OR ENVIRONMENTAL DAMAGE ("CRITICAL APPLICATIONS"). CIRRUS PRODUCTS ARE NOT DESIGNED, AUTHORIZED OR WARRANTED TO BE SUITABLE FOR USE IN PRODUCTS SURGICALLY IMPLANTED INTO THE BODY, AUTOMOTIVE SAFETY OR SECURITY DEVICES, LIFE SUPPORT PRODUCTS OR OTHER CRITICAL APPLICATIONS. INCLUSION OF CIRRUS PRODUCTS IN SUCH APPLICATIONS IS UNDERSTOOD TO BE FULLY AT THE CUSTOMER'S RISK AND CIRRUS DISCLAIMS AND MAKES NO WARRANTY, EXPRESS, STATUTORY OR IMPLIED, INCLUDING THE IMPLIED WARRANTIES OF MERCHANTABILITY AND FITNESS FOR PARTICULAR PURPOSE, WITH REGARD TO ANY CIRRUS PRODUCT THAT IS USED IN SUCH A MANNER. IF THE CUSTOMER OR CUSTOMER'S CUSTOMER USES OR PERMITS THE USE OF CIRRUS PRODUCTS IN CRITICAL APPLICATIONS, CUSTOMER AGREES, BY SUCH USE, TO FULLY INDEMNIFY CIRRUS, ITS OFFICERS, DIRECTORS, EMPLOYEES, DISTRIBUTORS AND OTHER AGENTS FROM ANY AND ALL LIABILITY, INCLUDING ATTORNEYS' FEES AND COSTS, THAT MAY RESULT FROM OR ARISE IN CONNECTION WITH THESE USES.

Cirrus Logic, Cirrus, and the Cirrus Logic logo designs, Apex Precision Power, Apex and the Apex Precision Power logo designs are trademarks of Cirrus Logic, Inc. All other brand and product names in this document may be trademarks or service marks of their respective owners.