

# AUTOMOTIVE DIGITAL CLOCK IC

**IN7100**

## DESCRIPTION

IN7100 is a automotive digital clock, CMOS LSI. It drives fluorescent indicator panel directly. It can be driven by a 4.194304 MHz crystal oscillator or an external clock signal (1024 Hz). It has 4-ways display brightness control function and its display format is 12 hours.

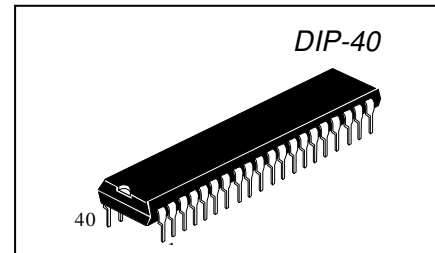

## FEATURES

- 4.194304 MHz crystal oscillator
- 4-ways display brightness control ( Segment signal duty: 1, 1/4, 1/8, 1/16 )
- Hours and Minutes Setting
- ± 30 seconds auto correction
- 1024 Hz external clock drive
- 1024 Hz SIGNAL output
- Segment Output: P-channel open drain
- 40 DIP package MS-011AC

## ABSOLUTE MAXIMUM RATINGS (Ta = 25 °C)

Parameter	Symbol	Specification	Unit
Power Supply Voltage	$V_{DD} - V_{SS}$	- 0.5 ~ + 8.0	V
Input Voltage	$V_{IN}$	$V_{SS} - 0.3 \sim V_{DD} + 0.3$	V
Output Voltage	$V_{OUT}$	$V_{DD} - 30 \sim V_{DD} + 0.3$	V
Operating Temperature	$T_a$	- 40 ~ + 85	°C
Storage Temperature	$T_{STG}$	- 55 ~ + 125	°C

## DC CHARACTERISTICS (Ta=25°C, RH≤70%, CD=CG=15pF, Xtal=4.194304MHz)

Characteristic	Symbol	Test Conditions	Min	Typ	Max	Unit
Power Supply Voltage	$V_{DD}-V_{SS}$		3.0	—	7.0	V
Power Supply Current	$I_{DD}$	No output loads, $V_{DD}=6V$	—	0.3	0.5	mA
Leakage Current	$I_{OFF}$	$V_{DD}-V_{SS}=5.0V$			5.0	μA
High Level Output Current <sup>(1)</sup>	$I_{OH1}$	$V_{DD}-V_{SS}=3.0V, V_{DD}-V_{OUT}=0.5V$	300	—	1500	μA
High Level Output Current <sup>(2)</sup>	$I_{OH2}$	$V_{DD}-V_{SS}=3.0V, V_{DD}-V_{OUT}=0.5V$	500	—	1800	μA
Low Level Output Current <sup>(3)</sup>	$I_{OL}$	$V_{DD}-V_{SS}=3.0V, V_{OUT}-V_{SS}=0.5V$	500	—	—	μA
High Level Input Current <sup>(4)</sup>	$I_{IH1}$	$V_{IN}=V_{DD}=6V$	—	15	30	μA
High Level Input Current <sup>(5)</sup>	$I_{IH2}$	$V_{IN}=V_{DD}=6V$	—	120	600	μA
External Clock Duty	$C_{LD}$		40	50	60	%
OSC. Feedback Resistance	$R_F$	$V_{DD}=6V$		3		MΩ

( $V_{DD}-V_{SS}=3.0\sim 7.0V, T_a = -40 \sim +85^\circ C, RH\leq 70\%, CD=CG=15pF, Xtal=4.194304MHz$ )

Characteristic	Symbol	Test Conditions	Min	Typ	Max	Unit
Power Supply Current	$I_{DD}$	No output loads	—	—	0.5	mA
High Level Output Current <sup>(1)</sup>	$I_{OH1}$	$V_{DD}-V_{SS}=3.0V, V_{DD}-V_{OUT}=0.5V$	250	—	—	$\mu A$
High Level Output Current <sup>(2)</sup>	$I_{OH2}$	$V_{DD}-V_{SS}=3.0V, V_{DD}-V_{OUT}=0.5V$	400	—	—	$\mu A$

- (1) for segment other than bc4, ad2, 1Hz
- (2) for segment bc4, ad2, 1Hz and CLOUT
- (3) for CLOUT
- (4) for DS1, DS2, RES, HS, MS and BLK
- (5) for T1, T2, T3 and AC

**PIN CONFIGURATION**

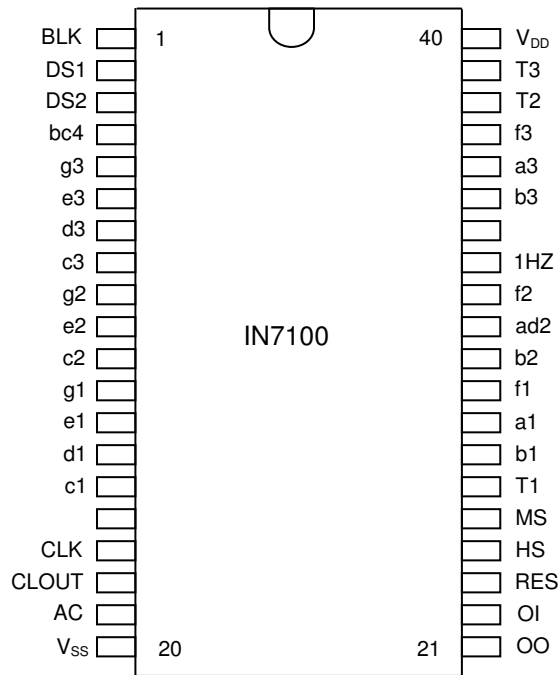

40-DIP MS-011AC

Block Diagram

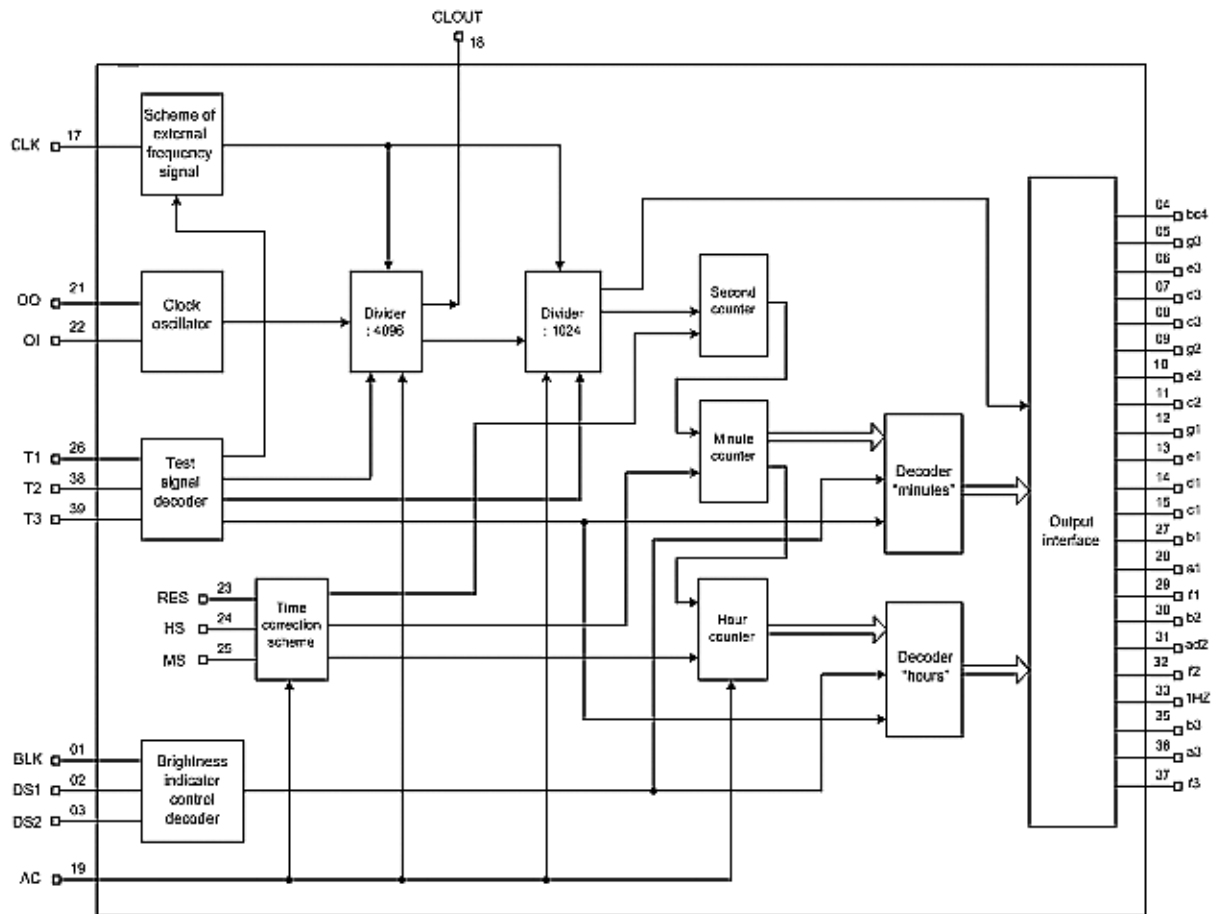

Block Diagram (for die)

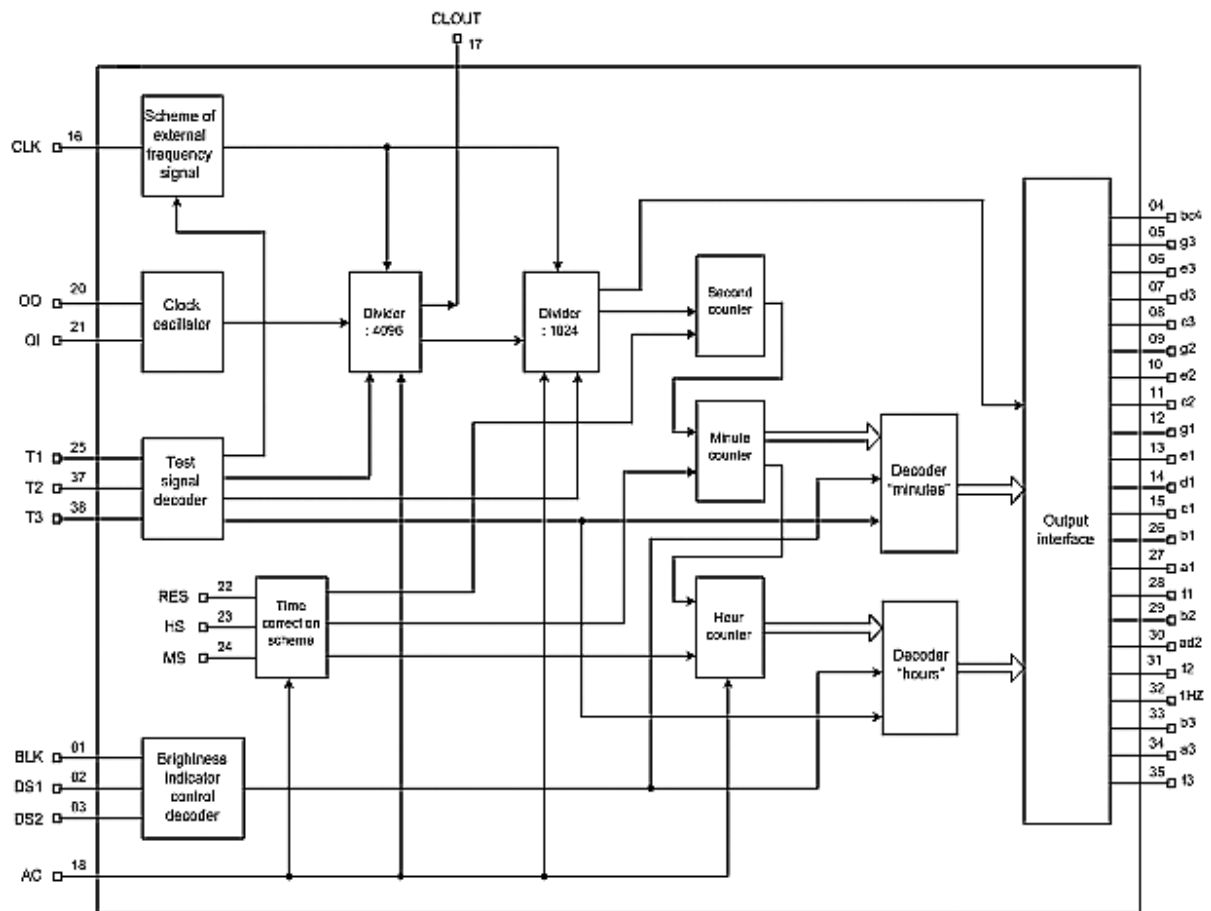



“Keeping Time” Application

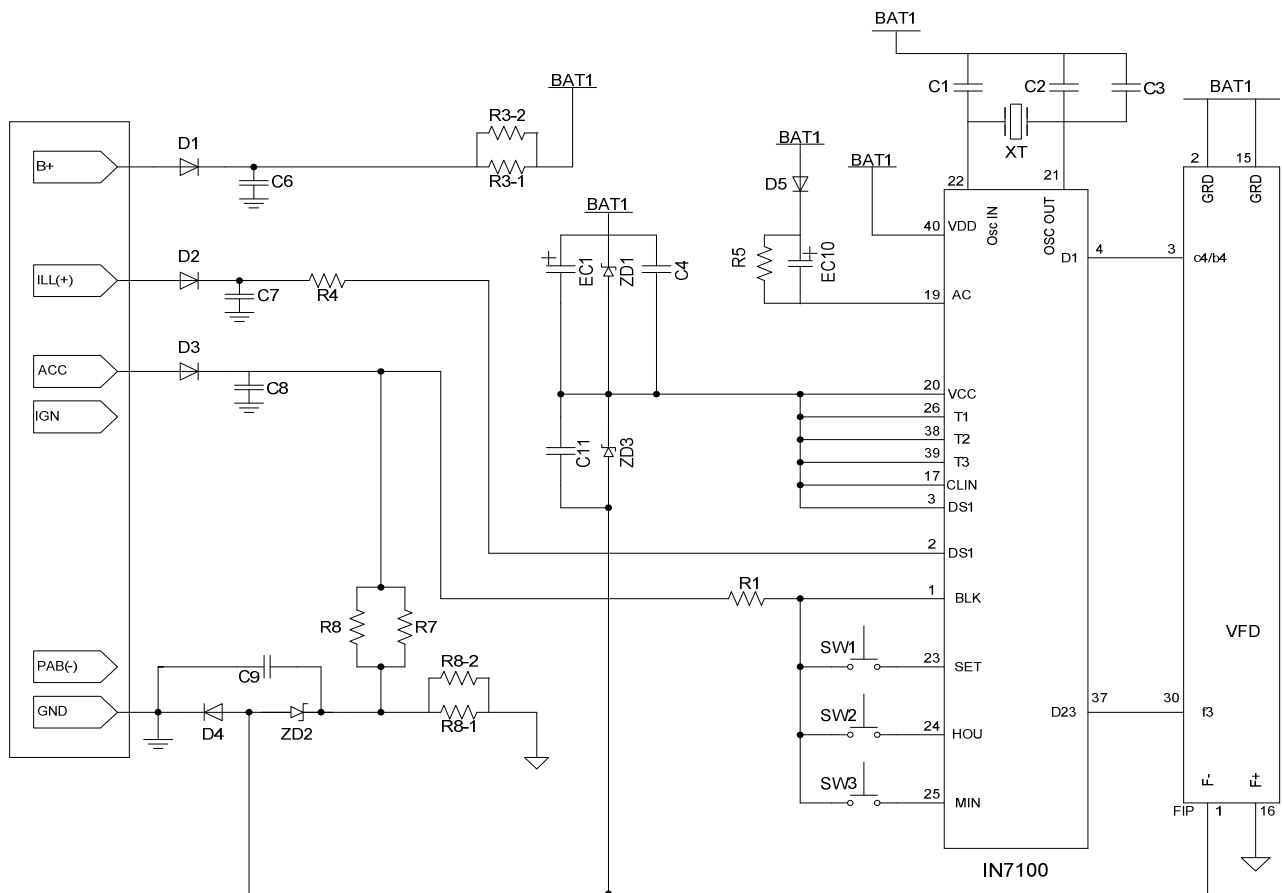

Part List

S/No	PART	Q'NTY
IC1	IN7100	1
VFD	SVC-01MS01	1
XT	4194304hz	1
C1	10pF	1
C2	15pF	1
C3	1~12pF ADJ	1
EC1	470uF, 25V	1
EC10	22uF, 10V	1
C4	104	1
C11	104	1
C6~9	104	4
R1	68k, 1/4w	1
R2	-	-

S/No	PART	Q'NTY
R3-1~2	560, 1/4W	2
R4	100k, 1/8W	1
R5	560k, 1/8W	1
R6	130, 2W	1
R7	130, 2W	1
R8-1~2	56, 1/4W	2
ZD1	1N4735A	1
ZD2	1N4732A	1
ZD3	1N4729A	1
SW1~3	Switch(THH-10910)	3
D1~4	1N4007	4
D5	1N4148	1
CON1	Connector(5566-05A)	1

## PIN DESCRIPTION

PIN #	NAME H	I/O	DESCRIPTION															
1	BLK	I	BLANKING INPUT; When this pin is low state, FIP is off and the operation of HS, MS, RES, switch is blocking, or vice versa															
2	DS1	I	DIMMER INPUT1, DIMMER INPUT2; This PIN control the brightness of FIP. Duty of segment output is determined depend on the level of DS1, DS2															
3	DS2	I																
			<table border="1"> <tr> <td>DS1</td> <td>V<sub>DD</sub></td> <td>V<sub>SS</sub></td> <td>V<sub>DD</sub></td> <td>V<sub>SS</sub></td> </tr> <tr> <td>DS2</td> <td>V<sub>DD</sub></td> <td>V<sub>DD</sub></td> <td>V<sub>SS</sub></td> <td>V<sub>SS</sub></td> </tr> <tr> <td>DUTY</td> <td>1/16</td> <td>1/8</td> <td>1/4</td> <td>1</td> </tr> </table>	DS1	V <sub>DD</sub>	V <sub>SS</sub>	V <sub>DD</sub>	V <sub>SS</sub>	DS2	V <sub>DD</sub>	V <sub>DD</sub>	V <sub>SS</sub>	V <sub>SS</sub>	DUTY	1/16	1/8	1/4	1
DS1	V <sub>DD</sub>	V <sub>SS</sub>	V <sub>DD</sub>	V <sub>SS</sub>														
DS2	V <sub>DD</sub>	V <sub>DD</sub>	V <sub>SS</sub>	V <sub>SS</sub>														
DUTY	1/16	1/8	1/4	1														
4	bc4	O	SEGMENT OUTPUT															
5	g3	O	SEGMENT OUTPUT															
6	e3	O	SEGMENT OUTPUT															
7	d3	O	SEGMENT OUTPUT															
8	c3	O	SEGMENT OUTPUT															
9	g2	O	SEGMENT OUTPUT															
10	e2	O	SEGMENT OUTPUT															
11	c2	O	SEGMENT OUTPUT															
12	g1	O	SEGMENT OUTPUT															
13	e1	O	SEGMENT OUTPUT															
14	d1	O	SEGMENT OUTPUT															
15	c1	O	SEGMENT OUTPUT															
16	--	--	<i>NO CONNECTION</i>															
17	CLK	I	EXTERNAL CLOCK INPUT; External clock of 1024 Hz frequency can drive the IC operation															
18	CLOUT	O	CLOCK OUTPUT; Clock of 1024 Hz frequency is generated when using 4.194304 MHz crystal															
19	AC	I	CLEAR INPUT (power on reset input pin)															
20	VSS	I	GROUND															
21	OO	O	OSCILLATOR OUTPUT (4.194304 MHz crystal output)															
22	OI	I	OSCILLATOR INPUT (4.194304 MHz crystal input)															
23	RES	I	RES INPUT ( $\pm 30$ minutes auto correction Input)															
24	HS	I	HOUR ADJUST INPUT															
25	MS	I	MINUTE ADJUST INPUT															
26	T1	I	TEST PIN1															
27	b1	O	SEGMENT OUTPUT															
28	a1	O	SEGMENT OUTPUT															
29	f1	O	SEGMENT OUTPUT															
30	b2	O	SEGMENT OUTPUT															
31	ad2	O	SEGMENT OUTPUT															
32	f2	O	SEGMENT OUTPUT															
33	1HZ	O	SEGMENT OUTPUT (colon)															
34	--	--	<i>NO CONNECTION</i>															
35	b3	O	SEGMENT OUTPUT															
36	a3	O	SEGMENT OUTPUT															
37	f3	O	SEGMENT OUTPUT															
38	T2	I	TEST PIN2															
39	T3	I	TEST PIN3															
40	V <sub>DD</sub>	I	POWER SUPPLY															

## INTERNAL STATE

pull down: BLK, DS1, DS2, AC, RES, HS, MS, TE1, TE2, TE3

P-ch OPEN DRAIN: bc4, g3, e3, d3, c3, g2, e2, c2, g1, e1, d1, c1, b1, a1, f1, b2, ad2, f2, 1Hz, b3, a3, f3

## 40-Pin Plastic Dual-in-Line

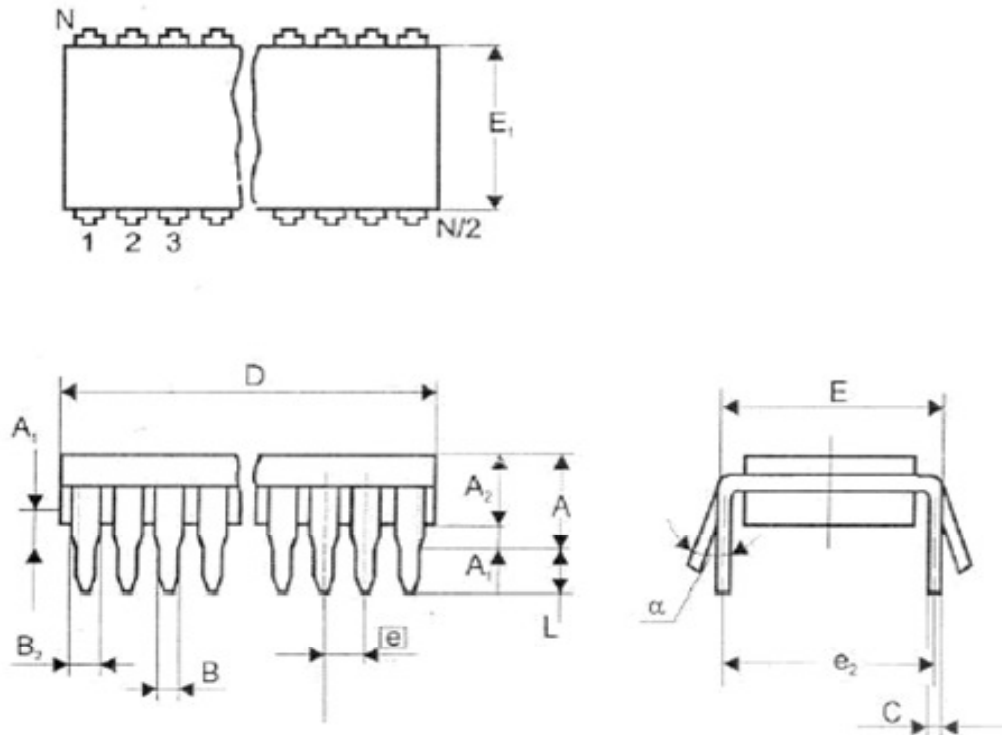

<i>Dimension, mm</i>		
A	max	6.35
A1	min	0.38
A2	min	3.18
	max	4.95
B	min	0.36
	max	0.56
B2	min	0.77
	max	1.78
C	min	0.20
	max	0.38
D	min	50.30
	max	53.20
E	min	15.24
	max	15.87
E1	min	12.32
	max	14.73
e	nom	2.54
e2	nom	15.24
L	min	2.92
	max	5.08
$\alpha$	min	0°
	max	10°