

CRYSTAL CONTROLLED OSCILLATORS

SURFACE MOUNT 5.0V HCMOS STRATUM 3 OCXO

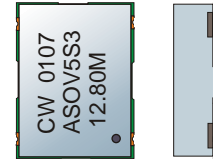

ASOV5S3

ABSOLUTE MAXIMUM RATINGS

TABLE 1.0

PARAMETER	UNITS	MINIMUM	NOMINAL	MAXIMUM	UNITS	NOTE
Storage Temperature		-40	-	85	°C	
Supply Voltage	(Vcc)	-0.5	-	7.0	Vdc	
Control Voltage	(Vc)	-0.5	-	7.0	Vdc	

OPERATING SPECIFICATIONS

TABLE 2.0

PARAMETER		MINIMUM	NOMINAL	MAXIMUM	UNITS	NOTE
Center Frequency	(Fo)	1.544	-	20.0	MHz	
Frequency Calibration, Vc=2.18 Vdc		-1.5	-	1.5	ppm	1
Frequency Stability		-0.25	-	0.25	ppm	2
Aging (Daily)		-30	-	30	ppb	3
Aging (20 Years)		-2.5	-	2.5	ppm	
Total Frequency Tolerance		-4.6	-	4.6	ppm	4
Operating Temperature Range		0	-	70	°C	
Supply Voltage	(Vcc)	4.75	5.0	5.25	Vdc	
Supply Current	(Icc)	-	-	350	mA	
Phase Jitter (BW=12KHz to 20MHz)		-	-	1	ps rms	
Phase Jitter (BW=10Hz to 20MHz)		-	-	3	ps rms	
Period Jitter		-	-	3	ps rms	
SSB Phase Noise at 10Hz offset		-	-90	-	dBc/Hz	
SSB Phase Noise at 10KHz offset		-	-135	-	dBc/Hz	
Start Up Time: Oscillator		-	-	10	mS	
Warm Up Time		-	-	5	Minutes	5
TDEV @ 1.0 Sec.		-	-	1	nS	
TDEV @ 4.0 Sec.		-	-	2	nS	

INPUT CHARACTERISTICS

TABLE 3.0

PARAMETER		MINIMUM	NOMINAL	MAXIMUM	UNITS	NOTE
Control Voltage Range	(Vc)	0.5	2.18	4.1	Vdc	
Frequency at Vc=0.3 Vdc		-30	-	-18	ppm	6
Frequency at Vc=3.0 Vdc		18	-	30	ppm	6
Slope of Frequency Adjust		5	-	-	ppm/V	
Input Impedance		100k	-	-	Ohm	

HCMOS OUTPUT CHARACTERISTICS

TABLE 4.0

PARAMETER		MINIMUM	NOMINAL	MAXIMUM	UNITS	NOTE
LOAD		-	-	15	pf	
Voltage (High)	(Voh)	4.5	-	-	Vdc	
(Low)	(Vol)	-	-	0.4	Vdc	
Current (High)	(Ioh)	-4	-	-	mA	
(Low)	(Iol)	-	-	4	mA	
Duty Cycle at 50% of Vcc		45	50	55	%	
Rise / Fall Time 10% to 90%		-	-	6	nS	

PACKAGE CHARACTERISTICS

TABLE 5.0

Package	Surface Mount, Non-hermetic package consisting of an FR4 substrate with grounded metal cover.
---------	---

PROCESS RECOMMENDATIONS

TABLE 6.0

Solder Reflow	The component solder used internal to this device has a melting point of 221°C. The peak temperature inside the device should be less than or equal to 220°C for a maximum of 10 seconds
Wash	Ultrasonic cleaning is not recommended

Notes:

- 1) Initial calibration @ 25°C, Vc=2.18 Vdc.
- 2) Frequency vs. temperature stability
- 3) At the time of shipment after 48 hours of operation.
- 4) Inclusive of calibration, operating temperature range, supply voltage change, load change, shock and vibration, 20 years aging, Vc=2.18 Vdc.
- 5) Measured @ 25°C, within 5 minutes, the unit will be within +/-0.1ppm of its reference frequency, measured after 30 minutes of continuous operation at a stable 25°C
- 6) Referenced to Fo @ 25°C, Positive Transfer Characteristic

DESCRIPTION

The Connor-Winfield ASOV5S3 is a true Surface Mount 5.0V Oven Controlled Crystal Oscillator (OCXO) with an HCMOS output. The ASOV5S3 is designed for Stratum 3 applications requiring tight frequency stability and low jitter.

FEATURES

- FREQUENCY ADJUST
- 5.0V OPERATION
- LOW JITTER <1pS RMS
- TEMPERATURE STABILITY ±0.25ppm
- FREQUENCY TOLERANCE OF ±4.6ppm OVER TWENTY YEARS
- SURFACE MOUNT PACKAGE
- TAPE AND REEL PACKAGING

ORDERING INFORMATION

ASOV5S3 - 12.80MHz

OCXO SERIES CENTER FREQUENCY

Specifications subject to change without notice.

CRYSTAL CONTROLLED OSCILLATORS

ENVIRONMENTAL CHARACTERISTICS

Temperature Cycle: Per MIL-STD-883, Method 1010, Condition B. -55°C to 125°C, 20 cycles, 10 minute dwell, 1 minute transition.

SOLDERING

Pad Solderability: Per MIL-STD-883, Method 200. 8 hour steam age prior to 254°C ±5°C Solder pot dip, 95% Coverage.

Solder Reflow: The component solder internal to this device has a melting point of 221°C, the peak temperature inside the device should be less than or equal to 220°C for a maximum of 10 seconds.

MECHANICAL CHARACTERISTICS

Vibration: Per MIL-STD-202, Method 204, Condition A. 10G's peak, 10Hz to 500Hz, 15minute cycles 12 times each perpendicular axis.

Shock: Per MIL-STD-202, Method 213, Condition D. 500G's, 1ms, halfsine, 3 shocks per direction.

Moisture Resistance: Per MIL-STD-202, Method 106. 95% RH @ 65°C, 10 cycles 10°C to 65°C.

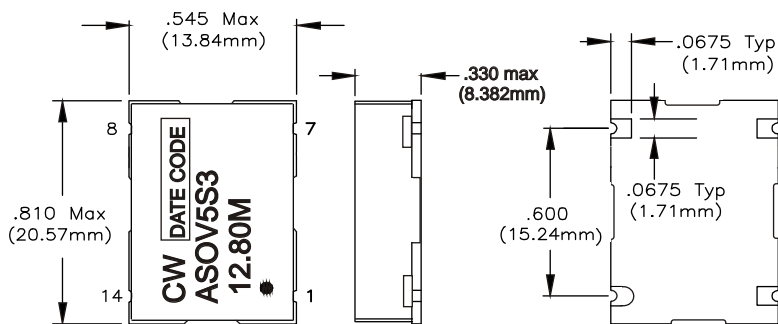

PIN	FUNCTION
1	CONTROL VOLTAGE
7	GROUND (CASE)
8	OUTPUT
14	Vcc

Dimensional Tolerance:
±.005 (.127mm)

OUTPUT WAVEFORM

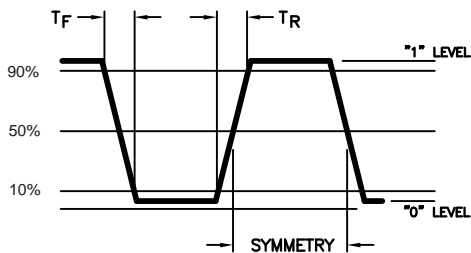

SUGGESTED PAD LAYOUT

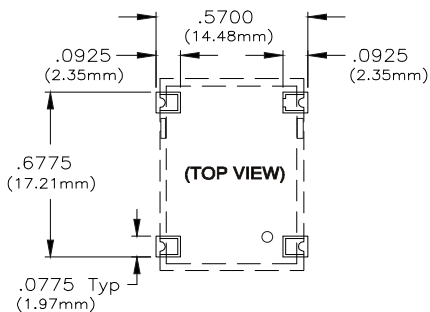

KEEP OUT AREA

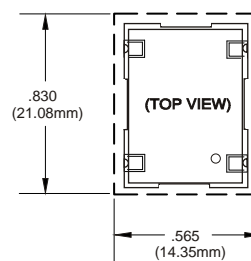

TEST DIAGRAM

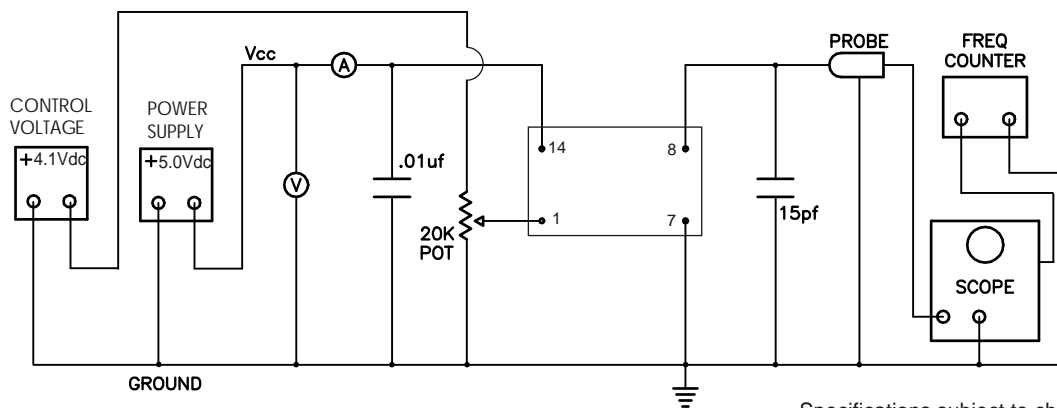

Specifications subject to change without notice.