

# AMMC-5023

23 GHz Low Noise Amplifier (21.2 – 26.5 GHz)

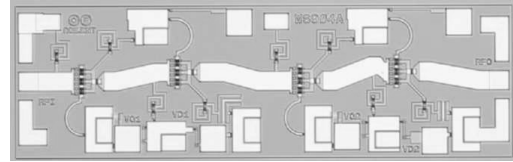

## Data Sheet



**Chip Size:** 1880 x 600  $\mu\text{m}$  (74 x 23.6 mils)  
**Chip Size Tolerance:**  $\pm 10 \mu\text{m}$  ( $\pm 0.4$  mils)  
**Chip Thickness:**  $100 \pm 10 \mu\text{m}$  ( $4 \pm 0.4$  mils)  
**Pad Dimensions:**  $80 \times 80 \mu\text{m}$  (3.1 x 3.1 mils), or larger

### Description

Avago's AMMC-5023 is a high gain, low noise amplifier that operates from 21 GHz to over 30 GHz. By eliminating the complex tuning and assembly processes typically required by hybrid (discrete-FET) amplifiers, the AMMC-5023 is a cost-effective alternative in both 21.2–23.6 GHz and 24.5–26.5 GHz communications receivers. The device has good input and output match to 50 Ohm and is unconditionally stable to more than 40 GHz. The backside of the chip is both RF and DC ground. This helps simplify the assembly process and reduces assembly related performance variations and costs. It is fabricated in a PHEMT process to provide exceptional noise and gain performance. For improved reliability and moisture protection, the die is passivated at the active areas.

### Features

- Frequency range: 21.2 – 26.5 GHz
- High gain: 23 dB
- Low noise figure: 2.3 dB
- Input and output return loss: >10 dB
- Single supply bias: 5 volts, 28 mA
- Optional bias adjust

### Applications

- Digital Radio Communication Systems (21.2–23.6 GHz and 24.5–26.5 GHz)
- Any narrow band application within 21 – 26 GHz
- 24.1 GHz collision avoidance
- Front-end gain stage

### Absolute Maximum Ratings<sup>[1]</sup>

| Symbol           | Parameters/Conditions           | Units              | Min. | Max. |
|------------------|---------------------------------|--------------------|------|------|
| $V_{D1}, V_{D2}$ | Drain Supply Voltage            | V                  |      | 8    |
| $V_{G1}, V_{G2}$ | Gate Supply Voltage             | V                  | 0.4  | 2    |
| $I_{D1}$         | Drain Supply Current            | mA                 |      | 35   |
| $I_{D2}$         | Drain Supply Current            | mA                 |      | 35   |
| $P_{in}$         | RF Input Power                  | dBm                |      | 15   |
| $T_{ch}$         | Channel Temperature             | $^{\circ}\text{C}$ |      | +150 |
| $T_b$            | Operating Backside Temperature  | $^{\circ}\text{C}$ | -55  | +140 |
| $T_{stg}$        | Storage Temperature             | $^{\circ}\text{C}$ | -65  | +165 |
| $T_{max}$        | Max. Assembly Temp (60 sec max) | $^{\circ}\text{C}$ |      | +300 |

### Notes:

1. Absolute maximum ratings for continuous operation unless otherwise noted.

## AMMC-5023 DC Specifications/Physical Properties<sup>[1]</sup>

| Symbol            | Parameters and Test Conditions  | Units                     | Min. | Typ. | Max. |
|-------------------|---|---------------------------|------|------|------|
| $V_{D1}, V_{D2}$  | Recommended Drain Supply Voltage  | V                         | 3    | 5    | 7    |
| $V_{G1}, V_{G2}$  | Gate Supply Voltage <sup>[2]</sup><br>( $V_{D1} \leq V_{D1(max)}$ , $V_{D2} \leq V_{D2(max)}$ )                     | V                         |      | 0.8  |      |
| $I_{D1}, I_{D2}$  | Input and Output Stage Drain Supply Current<br>( $V_{G1} = V_{G2} = \text{Open}$ , $V_{D1} = V_{D2} = 5\text{ V}$ ) | mA                        |      | 14   |      |
| $I_{D1} + I_{D2}$ | Total Drain Supply Current<br>( $V_{G1} = V_{G2} = \text{Open}$ , $V_{D1} = V_{D2} = 5\text{ V}$ )                  | mA                        | 13   | 28   | 35   |
| $\theta_{ch-b}$   | Thermal Resistance <sup>[3]</sup> (Backside temperature, $T_b = 25^\circ\text{C}$ )                                 | $^\circ\text{C}/\text{W}$ |      | 44   |      |

### Notes:

1. Backside ambient operating temperature  $T_A = 25^\circ\text{C}$  unless otherwise noted.
2. Open circuit voltage at  $V_{G1}$  and  $V_{G2}$  when  $V_{D1}$  and  $V_{D2}$  are 5 Volts.
3. Channel-to-backside Thermal Resistance ( $\theta_{ch-b}$ ) =  $66^\circ\text{C}/\text{W}$  at  $T_{channel} (T_c) = 150^\circ\text{C}$  as measured using the liquid crystal method. Thermal Resistance at backside temperature ( $T_b$ ) =  $25^\circ\text{C}$  calculated from measured data.

## RF Specifications<sup>[4]</sup>

( $V_{G1} = V_{G2} = \text{Open}$ ,  $V_{D1} = V_{D2} = 5\text{V}$ ,  $I_{D1} + I_{D2} = 28\text{ mA}$ ,  $Z_{in} = Z_0 = 50\Omega$ )

| Symbol             | Parameters and Test Conditions  | Units | 21.2 – 23.6 GHz |           |      | 24.5 – 26.5 GHz |           |      |
|--------------------|---|-------|-----------------|-----------|------|-----------------|-----------|------|
|                    |   |       | Min.            | Typ.      | Max. | Min.            | Typ.      | Max. |
| $ S_{21} ^2$       | Small-signal Gain   | dB    | 21              | 23.6      | 28   | 17              | 19        | 25   |
| $\Delta S_{21} ^2$ | Small-signal Gain Flatness  | dB    |                 | $\pm 1.5$ |      |                 | $\pm 1.2$ |      |
| $RL_{in}$          | Input Return Loss   | dB    | 10              | 12        |      | 10              | 11.5      |      |
| $RL_{out}$         | Output Return Loss  | dB    | 9               | 12        |      | 10              | 17        |      |
| $ S_{12} ^2$       | Isolation   | dB    | 40              | 50        |      | 40              | 43        |      |
| $P_{-1dB}$         | Output Power @ 1 dB Gain Compression<br>$f = 23\text{ GHz}$   | dBm   |                 | 9.5       |      |                 | 10        |      |
| $P_{sat}$          | Saturated Output Power<br>(@ 3 dB Gain Compression)   | dBm   |                 | 10.5      |      |                 | 11.5      |      |
| OIP3               | Output 3 <sup>rd</sup> Order Intercept Point,<br>$Rf_{in1} = Rf_{in2} = -20\text{ dBm}$ , $\Delta f = 2\text{ MHz}$ | dB    |                 | 18        |      |                 | 24        |      |
| NF                 | Noise Figure  | dB    |                 | 2.3       | 2.8  |                 | 2.3       | 2.8  |

### Note:

4. 100% on-wafer RF test is done at frequency = 21.2, 22.4, 23.6, 24.5, 25.5 and 26.5 GHz, except as noted.

### AMMC-5023 Typical Performance

( $T_{\text{chuck}} = 25^{\circ}\text{C}$ ,  $V_{D1} = V_{D2} = 5\text{V}$ ,  $V_{G1} = V_{G2} = \text{Open}$ ,  $Z_0 = 50\Omega$ )

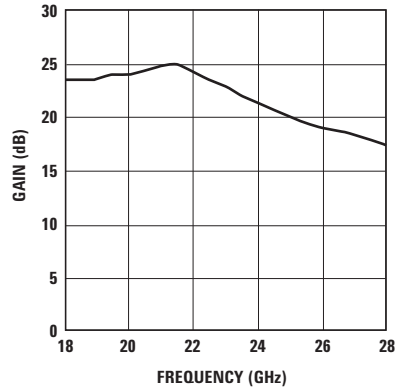

Figure 1. Gain.

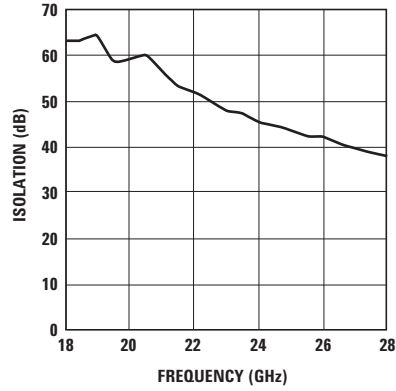

Figure 2. Isolation.

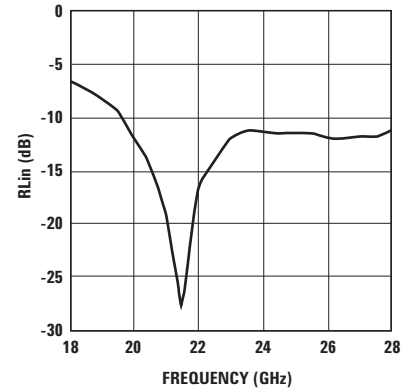

Figure 3. Input Return Loss.

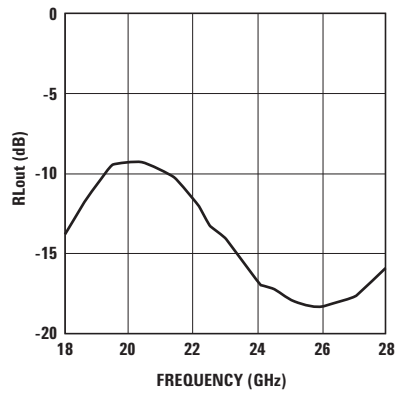

Figure 4. Output Return Loss.

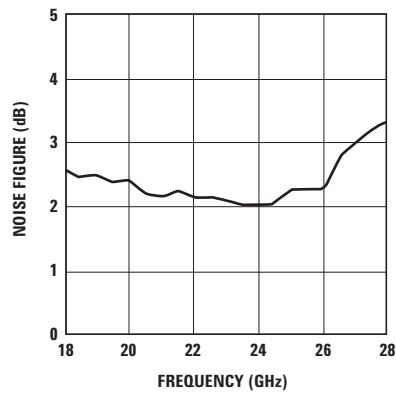

Figure 5. Noise Figure.

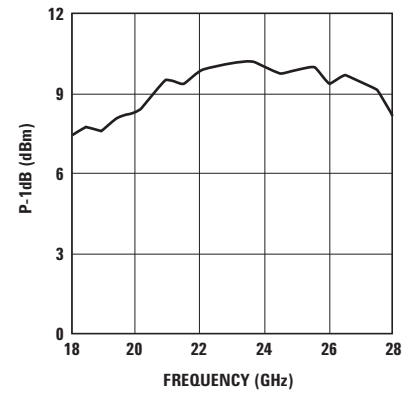

Figure 6. Output Power at 1dB Gain Compression.

### AMMC-5023 Typical Performance vs. Supply Voltage

( $T = 25^{\circ}\text{C}$ ,  $V_{D1} = V_{D2} = V_{DD}$ ,  $V_{G1} = V_{G2} = \text{Open}$ ,  $Z_0 = 50\Omega$ )

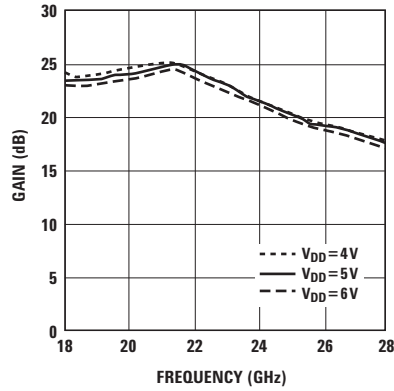

Figure 7. Gain and Voltage.

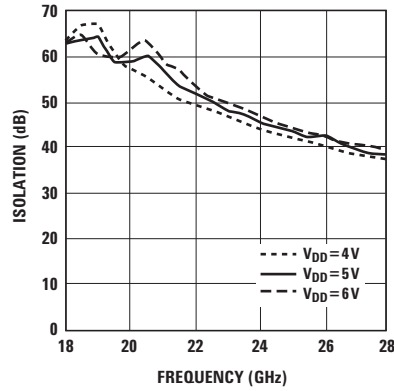

Figure 8. Isolation and Voltage.

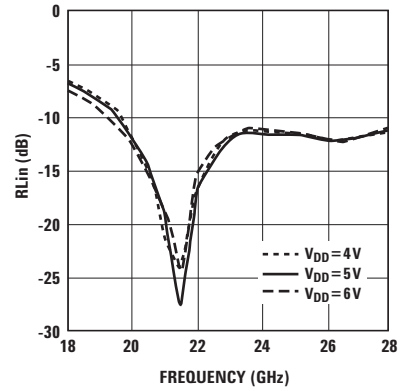

Figure 9. Input Return Loss and Voltage.

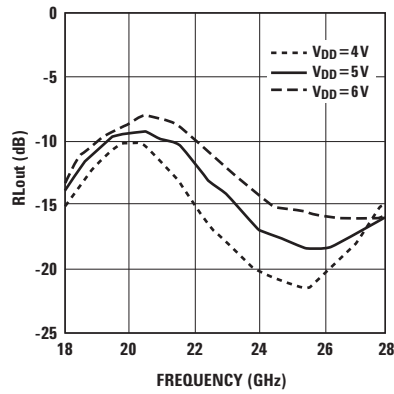

Figure 10. Output Return Loss and Voltage.

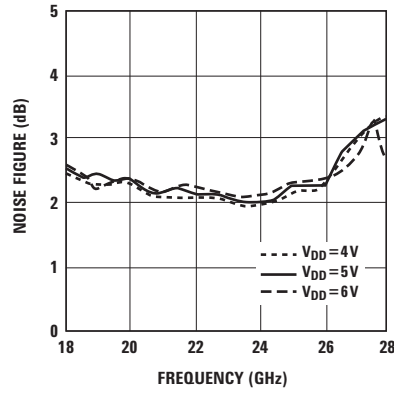

Figure 11. Noise Figure and Voltage.

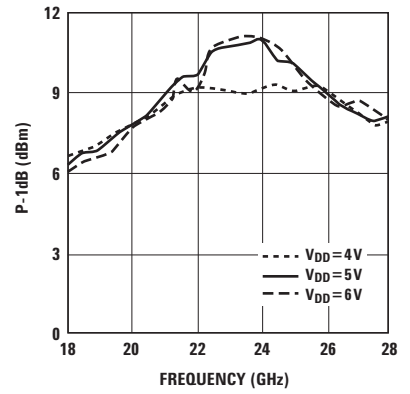

Figure 12. P-1dB and Voltage.

### AMMC-5023 Typical Performance vs. Temperature

( $V_{D1} = V_{D2} = V_{DD} = 5V, V_{G1} = V_{G2} = \text{Open}, Z_0 = 50\Omega$ )

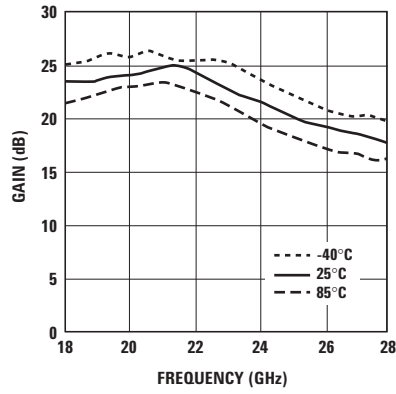

Figure 13. Gain and Temperature.

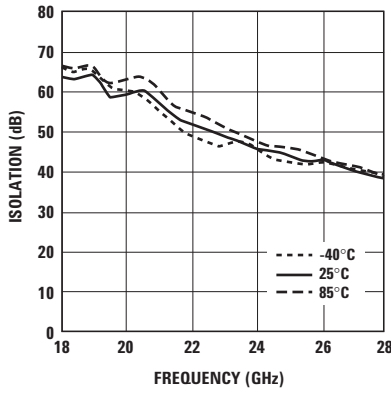

Figure 14. Isolation and Temperature.

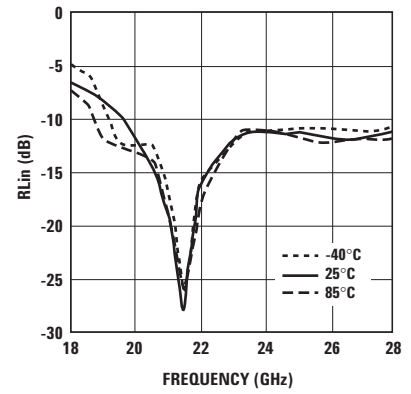

Figure 15. Input Return Loss and Temperature.

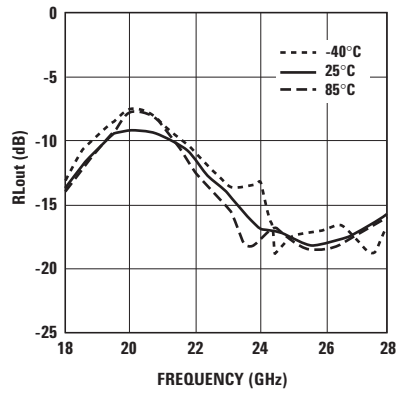

Figure 16. Output Return Loss and Temperature.

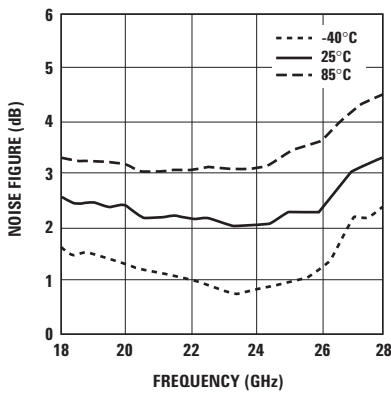

Figure 17. Noise Figure and Temperature.

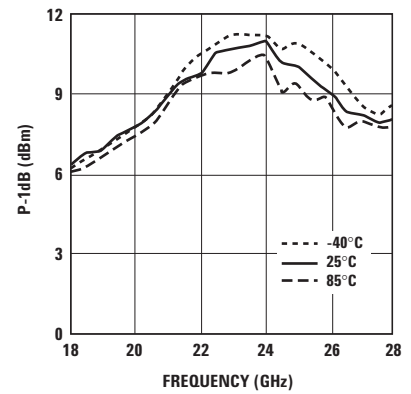

Figure 18. P-1dB and Temperature.

**AMMC-5023 Typical Scattering Parameters<sup>[1]</sup>** ( $T_c = 25^\circ\text{C}$ ,  $V_{D1} = V_{D2} = 5\text{V}$ ,  $I_{dd} = 28\text{mA}$ ,  $V_{G1} = V_{G2} = \text{Open}$ )

| Freq.<br>GHz | $S_{11}$ |        |        | $S_{12}$ |        |        | $S_{21}$ |        |        | $S_{22}$ |        |        |
|--------------|----------|--------|--------|----------|--------|--------|----------|--------|--------|----------|--------|--------|
|              | dB       | Mag    | Phase  | dB       | Mag    | Phase  | dB       | Mag    | Phase  | dB       | Mag    | Phase  |
| 18           | -6.813   | 0.4564 | 74.519 | -57.94   | 0.0013 | 1.7405 | 23.206   | 14.464 | 122.15 | -13.57   | 0.2096 | 51.531 |
| 18.2         | -7.202   | 0.4364 | 74.66  | -59.98   | 0.001  | -26.99 | 23.203   | 14.459 | 111.97 | -13.66   | 0.2076 | -73.76 |
| 18.4         | -7.266   | 0.4332 | 72.588 | -60.22   | 0.001  | 124.05 | 23.114   | 14.312 | 101.1  | -12.57   | 0.2354 | 165.76 |
| 18.6         | -7.644   | 0.4148 | 70.858 | -62.22   | 0.0008 | 17.763 | 23.114   | 14.313 | 91.174 | -11.74   | 0.2588 | 163.66 |
| 18.8         | -7.815   | 0.4067 | 67.349 | -58.93   | 0.0011 | 100.07 | 23.202   | 14.457 | 81.167 | -11.64   | 0.2618 | 157.71 |
| 19           | -8.46    | 0.3776 | 65.232 | -61.93   | 0.0008 | 76.42  | 23.282   | 14.592 | 71.291 | -10.45   | 0.3002 | 152.53 |
| 19.2         | -8.502   | 0.3758 | 62.276 | -63.28   | 0.0007 | 40.997 | 23.382   | 14.76  | 61.218 | -10.44   | 0.3006 | 150.28 |
| 19.4         | -9.293   | 0.343  | 56.815 | -57.84   | 0.0013 | 100.86 | 23.582   | 15.104 | 50.894 | -9.703   | 0.3272 | 141.82 |
| 19.6         | -10.62   | 0.2943 | 51.64  | -53.14   | 0.0022 | 60.218 | 23.787   | 15.464 | 39.572 | -8.943   | 0.3572 | 139.34 |
| 19.8         | -11.39   | 0.2694 | 54.737 | -55.77   | 0.0016 | 22.448 | 23.659   | 15.239 | 29.26  | -9.414   | 0.3383 | 129.99 |
| 20           | -12.13   | 0.2474 | 53.651 | -57.89   | 0.0013 | 1.7795 | 23.735   | 15.372 | 20.239 | -8.923   | 0.358  | 126.19 |
| 20.2         | -12.77   | 0.23   | 52.385 | -60.66   | 0.0009 | -42.99 | 23.882   | 15.635 | 10.031 | -9.317   | 0.3421 | 123.37 |
| 20.4         | -13.69   | 0.2067 | 49.224 | -57.48   | 0.0013 | -58.99 | 23.975   | 15.803 | 0.2045 | -8.817   | 0.3624 | 114.62 |
| 20.6         | -14.92   | 0.1795 | 46.249 | -54.44   | 0.0019 | -57.86 | 24.1     | 16.033 | -9.704 | -8.971   | 0.356  | 111.84 |
| 20.8         | -16.83   | 0.1441 | 42.376 | -56.15   | 0.0016 | -40.83 | 24.412   | 16.618 | -18.13 | -9.29    | 0.3432 | 103.37 |
| 21           | -19.11   | 0.1108 | 43.556 | -53.47   | 0.0021 | -53.53 | 24.479   | 16.748 | -28.97 | -9.167   | 0.3481 | 98.097 |
| 21.2         | -23.18   | 0.0693 | 33.667 | -57.14   | 0.0014 | -51.56 | 24.705   | 17.19  | -39.82 | -10.07   | 0.3138 | 94.38  |
| 21.4         | -30.15   | 0.0311 | 43.731 | -55.04   | 0.0018 | -53.75 | 24.755   | 17.288 | -52.67 | -10.209  | 0.3087 | 86.525 |
| 21.6         | -20.59   | 0.0934 | 155.16 | -52.25   | 0.0024 | -67.58 | 24.427   | 16.648 | -64.69 | -10.54   | 0.2971 | 83.119 |
| 21.8         | -17.93   | 0.1269 | 156.15 | -51.09   | 0.0028 | -88.01 | 24.235   | 16.284 | -75.32 | -11.06   | 0.2798 | 74.893 |
| 22           | -15.74   | 0.1634 | 148.96 | -54.03   | 0.002  | -110.5 | 23.892   | 15.654 | -84.97 | -11      | 0.2818 | 75.567 |
| 22.2         | -14.66   | 0.185  | 147.58 | -48.57   | 0.0037 | -108.8 | 23.656   | 15.233 | -95.11 | -11.99   | 0.2513 | 68.795 |
| 22.4         | -13.94   | 0.201  | 142.03 | -48.93   | 0.0036 | -108.6 | 23.362   | 14.727 | -104.6 | -11.98   | 0.2518 | 61.88  |
| 22.6         | -13.22   | 0.2184 | 142.09 | -48.25   | 0.0039 | -110   | 23.209   | 14.469 | -113.7 | -12.98   | 0.2243 | 62.905 |
| 22.8         | -12.04   | 0.2499 | 138.22 | -47.36   | 0.0043 | -124.1 | 22.914   | 13.986 | -124.1 | -13.6    | 0.2089 | 55.353 |
| 23           | -11.82   | 0.2565 | 133.62 | -47.42   | 0.0043 | -127.7 | 22.593   | 13.478 | -132.6 | -13.61   | 0.2086 | 59.509 |
| 23.2         | -11.7    | 0.2601 | 130.32 | -46.06   | 0.005  | -134.4 | 22.312   | 13.05  | -141.2 | -14.94   | 0.179  | 53.623 |
| 23.4         | -11.46   | 0.2672 | 129.24 | -46.7    | 0.0046 | -140.5 | 22.015   | 12.611 | -146   | -14.13   | 0.1965 | 50.5   |
| 23.6         | -11.18   | 0.276  | 125.92 | -46      | 0.005  | -148.6 | 21.767   | 12.256 | -154.2 | -15.3    | 0.1718 | 54.919 |
| 23.8         | -11.22   | 0.2749 | 124.18 | -45.25   | 0.0055 | -145.8 | 21.399   | 11.747 | -161.7 | -15.67   | 0.1646 | 41.768 |
| 24           | -11.3    | 0.2724 | 122.88 | -45.1    | 0.0056 | -153.6 | 21.206   | 11.49  | -169   | -15.63   | 0.1654 | 49.105 |
| 24.2         | -11.09   | 0.2789 | 122.15 | -44.25   | 0.0061 | -155.4 | 20.921   | 11.119 | 94.004 | -16.94   | 0.1423 | 38.655 |
| 24.4         | -11.32   | 0.2717 | 119.68 | -44.3    | 0.0061 | -167.3 | 20.626   | 10.748 | 170.24 | -15.98   | 0.1589 | 37.913 |
| 24.6         | -11.38   | 0.2698 | 118.72 | -43.4    | 0.0068 | -171.1 | 20.347   | 10.407 | 163.06 | -16.8    | 0.1445 | 40.066 |
| 24.8         | -11.41   | 0.269  | 118.3  | -43.43   | 0.0067 | -71.2  | 20.102   | 10.118 | 156.05 | -16.7    | 0.1463 | 22.655 |
| 25           | -11.62   | 0.2625 | 117.04 | -43.54   | 0.0067 | 137.17 | 19.854   | 9.8331 | 149.07 | -16.85   | 0.1436 | 28.818 |
| 25.2         | -11.89   | 0.2544 | 116.86 | -42.29   | 0.0077 | 133.77 | 19.696   | 9.6559 | 142.65 | -17.96   | 0.1265 | 12.448 |
| 25.4         | -11.81   | 0.2569 | 117.41 | -41.51   | 0.0084 | 162.99 | 19.475   | 9.4138 | 135.76 | -16.74   | 0.1456 | 11.766 |
| 25.6         | -12.06   | 0.2495 | 114.9  | -41.05   | 0.0089 | 157.69 | 19.17    | 9.0888 | 129.79 | -17.66   | 0.1309 | 22.237 |
| 25.8         | -12.55   | 0.2357 | 117.83 | -41.34   | 0.0086 | 150.4  | 19.077   | 8.9921 | 124.04 | -16.87   | 0.1433 | 0.7878 |
| 26           | -12.48   | 0.2378 | 120.31 | -41.95   | 0.008  | 145.28 | 18.968   | 8.8795 | 116.86 | -17.58   | 0.1322 | 8.5083 |
| 26.2         | -12.51   | 0.2367 | 121.69 | -40.55   | 0.0094 | 143.86 | 18.767   | 8.6771 | 110.73 | -17.75   | 0.1295 | -6.375 |
| 26.4         | -12.29   | 0.2429 | 123.23 | -39.89   | 0.0101 | 139.48 | 18.629   | 8.5402 | 103.45 | -16.9    | 0.1429 | -7.881 |
| 26.6         | -12.4    | 0.2398 | 123.93 | -39.92   | 0.0101 | 132.24 | 18.45    | 8.3655 | 97.292 | -17.16   | 0.1387 | -20.1  |
| 26.8         | -12.15   | 0.2468 | 125.41 | -40.2    | 0.0098 | 126.75 | 18.298   | 8.2203 | 90.776 | -16.55   | 0.1487 | -31.85 |
| 27           | -11.85   | 0.2556 | 125.81 | -39.47   | 0.0106 | 126.31 | 18.124   | 8.0576 | 83.96  | -17.36   | 0.1354 | -34.26 |
| 27.2         | -11.84   | 0.2558 | 124.87 | -39.17   | 0.011  | 123.8  | 17.881   | 7.8349 | 78.019 | -16.66   | 0.1468 | -49.17 |
| 27.4         | -11.86   | 0.2554 | 126.85 | -39.01   | 0.0112 | 119.72 | 17.756   | 7.7234 | 71.862 | -16.11   | 0.1564 | -51.07 |
| 27.6         | -11.53   | 0.2653 | 128.29 | -38.6    | 0.0118 | 114.03 | 17.589   | 7.5765 | 65.475 | -16.31   | 0.1529 | -64.97 |
| 27.8         | -11.31   | 0.2719 | 127.51 | -38.23   | 0.0123 | 110.58 | 17.389   | 7.4038 | 59.28  | -14.98   | 0.1782 | -68.69 |
| 28           | -11.04   | 0.2804 | 128.43 | -38.11   | 0.0124 | 103.56 | 17.23    | 7.2697 | 53.236 | -15.44   | 0.1691 | -76.56 |

**Note:**

1. Data obtained from on-wafer measurements.

## Biasing and Operation

The AMMC-5023 has four cascaded gain stages as shown in Figure 19. The first two gain stages at the input are biased with the  $V_{D1}$  drain supply. Similarly, the two output stages are biased with the  $V_{D2}$  supply. Standard LNA operation is with a single positive DC drain supply voltage ( $V_{D1}=V_{D2}=5\text{ V}$ ) as shown in the assembly diagram, Figure 2(a).

If desired, the output stage DC supply voltage ( $V_{D2}$ ) can be increased to improve output power capability while maintaining optimum low noise bias conditions for the input section. The output power may also be adjusted by applying a positive voltage at  $V_{G2}$  to alter the operating bias point for both the output FETs. Increasing the voltage applied to  $V_{G2}$  (more positively) results in a more negative gate-to-source voltage and, therefore, lower drain current. Figures 20(b) and 20(c) illustrate how the device can be assembled for independent drain supply operation and for output stage gate bias control.

## Assembly Techniques

The backside of the MMIC chip is RF ground. For microstrip applications the chip should be attached directly to the ground plane (e.g. circuit carrier or heatsink) using electrically conductive epoxy<sup>[1,2]</sup>. For conductive epoxy, the amount should be just enough to provide a thin fillet around the bottom perimeter of the die. The ground plane should be free of any residue that may jeopardize electrical or mechanical attachment. Caution should be taken to not exceed the Absolute Maximum Rating for assembly temperature and time.

Thermosonic wedge bonding is the preferred method for wire attachment to the bond pads. The RF connections should be kept as short as possible to minimize inductance. Gold mesh or double-bonding with 0.7 mil gold wire is recommended.

Mesh can be attached using a 2 mil round tracking tool and a tool force of approximately 22 grams with an ultrasonic power of roughly 55 dB for a duration of  $76 \pm 8\text{ mS}$ . A guided wedge at an ultrasonic power level of 64 dB can be used for the 0.7 mil wire. The recommended wire bond stage temperature is  $150 \pm 2^\circ\text{C}$ .

The chip is 100 mm thick and should be handled with care. This MMIC has exposed air bridges on the top surface. Handle at edges or with a custom collet (do not pick up die with vacuum on die center.)

This MMIC is also static sensitive and ESD handling precautions should be taken.

### Notes:

1. Ablebond 84-1 LM1 silver epoxy is recommended.
2. Eutectic attach is not recommended and may jeopardize reliability of the device.

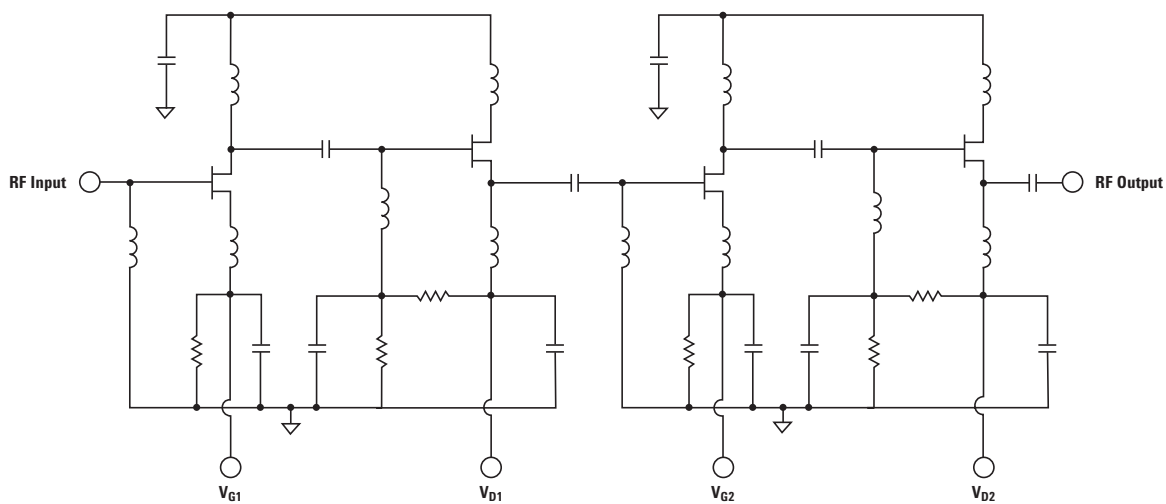
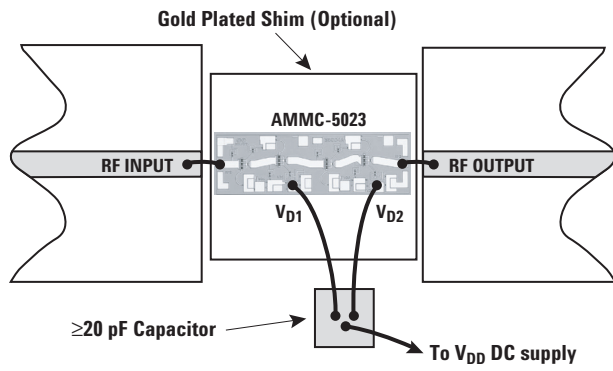
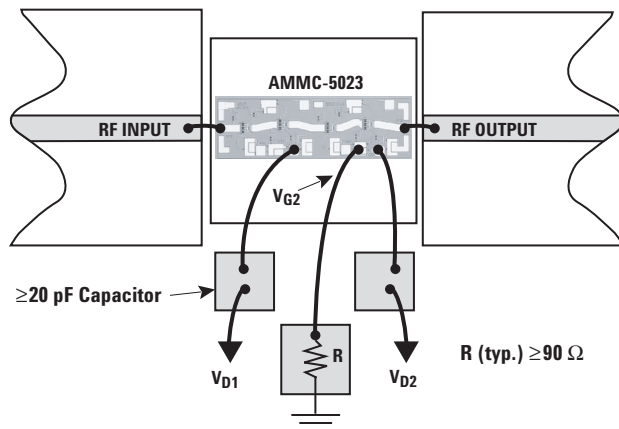

Figure 19. AMMC-5023 Schematic.



(a) Single DC Drain Supply Voltage.



(b) Assembly for custom biasing of output gain stages using an external chip-resistor.

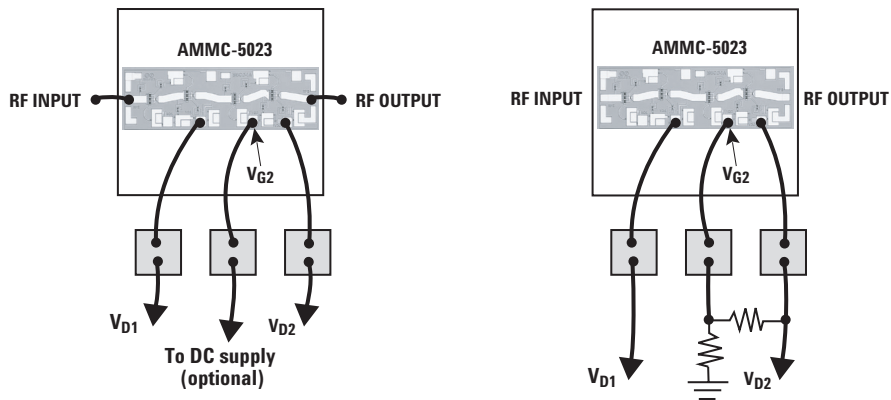

(c) A  $V_{G2}$  DC Supply or a resistive divider network can also be used to bias the output stages for custom application.

Figure 20. AMMC-5023 Assembly Diagrams.



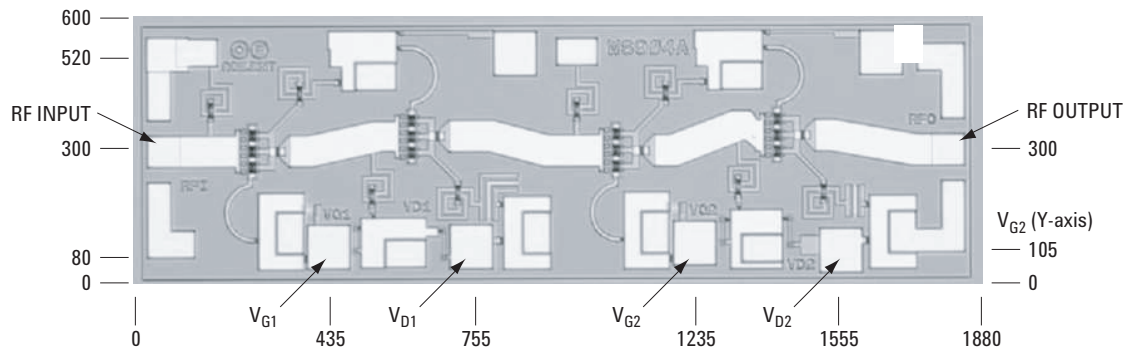

**Figure 21. AMMC-5023 Bonding Pad Locations.**  
(dimensions in micrometers)

### Ordering Information

AMMC-5023-W10 = 10 devices per tray

AMMC-5023-W50 = 50 devices per tray

For product information and a complete list of distributors, please go to our web site: [www.avagotech.com](http://www.avagotech.com)

Avago, Avago Technologies, and the A logo are trademarks of Avago Technologies Limited in the United States and other countries.  
Data subject to change. Copyright © 2005-2008 Avago Technologies Limited. All rights reserved. Obsoletes 5989-3930EN  
AV02-1313EN - May 29, 2008

