

MSX-50 Photovoltaic Modules



The MSX-50 is a midsize photovoltaic module in Solarex's Megamodule™ series, a product line which is the industry standard for reliability, durability and value. It is well-suited to applications requiring the ruggedness and other premium characteristics—such as the 20-year warranty—of Solarex's larger MSX modules, but needing 50 watts peak output. Typical uses include remote habitations, instrumentation systems, security sensors, and navigation aids.

With 36 polycrystalline silicon solar cells in series, the MSX-50 charges batteries efficiently in virtually any climate. It may be used in single-module arrays or deployed in multiple-module arrays, wired in series/parallel combinations as required to meet current and voltage requirements. The MSX-50 is engineered under Solarex's IntegraSystem™ system integration concept, which ensures full compatibility with other Solarex subsystems and components (support hardware, regulators, etc.) and easy system assembly.

Individually Tested, Labeled and Warranted

As part of the final inspection procedure, every MSX module is tested in a solar simulator and labeled with its actual output—voltage, current, and power at maximum power point (P_{max})—at Standard Test Conditions and Standard Operating Conditions. Furthermore, the MSX-50 is covered by our industry-leading limited warranty, which guarantees:

- that no module will generate less than its guaranteed minimum P_{max} when purchased;
- at least 80% of the guaranteed minimum P_{max} for twenty years.

Contact Solarex's Marketing Department for full terms and limitations of this unparalleled warranty.

Reliable and Versatile

The Megamodule series has proved its reliability at thousands of installations in every climate on Earth. Among the features that contribute to its versatility:

Dual Voltage Capability

These modules consist of 36 polycrystalline silicon solar cells electrically configured as two series strings of 18 cells each. The strings terminate in the junction box on the module back. Shipped in 12V configuration, modules may easily be switched to 6V configuration in the field by moving leads in the junction box. This design also allows

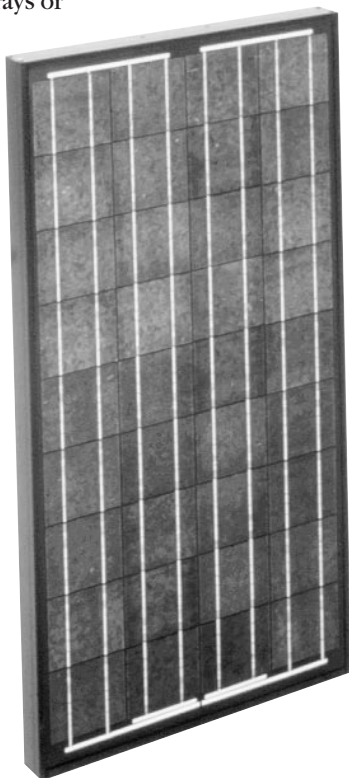

installation of bypass diodes on 18-cell strings, which can improve reliability and performance in systems with nominal voltage 24V and above.

High-Capacity Multifunction Junction Box

The size of the junction box (25 cubic inches, 411cc) and its six-terminal connection block allow most system array connections (putting multiple modules in series or parallel) to be made right in the J-box. The box also can accommodate bypass or blocking diodes or a small regulator. In many instances, this saves the expense and labor of fitting additional boxes. The box is raintight (IP54 rated) and accepts 1/2" nominal or PG13.5 conduit or cable fittings. The standard terminals accept wire as large as AWG #10 (6mm²); an optional terminal block accepts wire up to AWG #4 (25mm²). Both blocks accept preformed terminations or bare wire.

Proven Materials and Construction

Megamodule materials reflect Solarex's quarter-century of experience with solar modules and systems installed in virtually every climate on Earth.

- Polycrystalline silicon solar cells: efficient, attractive, stable.
- Modules are rugged and weatherproof: cell strings are laminated between sheets of ethylene vinyl acetate (EVA) and tempered glass with a durable Tedlar backsheet.
- Tempered glass superstrate is highly light-transmissive (low iron content), stable, and impact-resistant.
- Corrosion-resistant, bronze-anodized extruded aluminum frame is strong, attractive, compatible with Solarex mounting hardware and most other mounting structures.

Safety Approved

The MSX-50 module is listed by Underwriter's Laboratories for electrical and fire safety (Class C fire rating), certified by TÜV Rheinland as Class II equipment, and approved by Factory Mutual Research for application in NEC Class 1, Division 2, Group C & D hazardous locations.



APPROVED



TÜV
Rheinland

More than 20 years ago, Solarex made the first polycrystalline silicon solar cell, advancing photovoltaics beyond the first-generation monocrystalline technology developed for electronics. Developed specifically for photovoltaics, polycrystalline silicon is used in Solarex's Mega™ series to provide a wide range of attractive, efficient modules. They require substantially less energy to manufacture and generate substantially more energy per rated watt than other crystalline silicon modules.



Options

- Blocking and bypass diodes
- Solarstate™ charge regulator

Quality certified

MSX-50 modules are manufactured in our ISO 9001-certified factories to demanding specifications, and are designed to comply with IEC 1215, IEEE 1262 and CEC 503 test requirements, including:

- repetitive cycling between -40°C and 90°C;
- repetitive cycling between -40°C and 85°C at 85% relative humidity;
- simulated impact of one-inch (25 mm) hail at terminal velocity;
- 2700 VDC frame/cell string isolation test;
- performance at low light levels;
- a "damp heat" test, consisting of 1000 hours of exposure to 85°C and 85% relative humidity;
- a "hot-spot" test, which determines a module's ability to tolerate localized shadowing (which can cause reverse-biased operation and localized heating);
- resistance to UV degradation;
- robustness of electrical terminations;
- simulated wind loading of 125 mph (200 kph).

Mechanical Characteristics

Weight: 11.8 pounds (5.35 kg)

Dimensions: Dimensions in brackets are in millimeters. Unbracketed dimensions are in inches. Overall tolerances $\pm 1/8"$ (3mm)

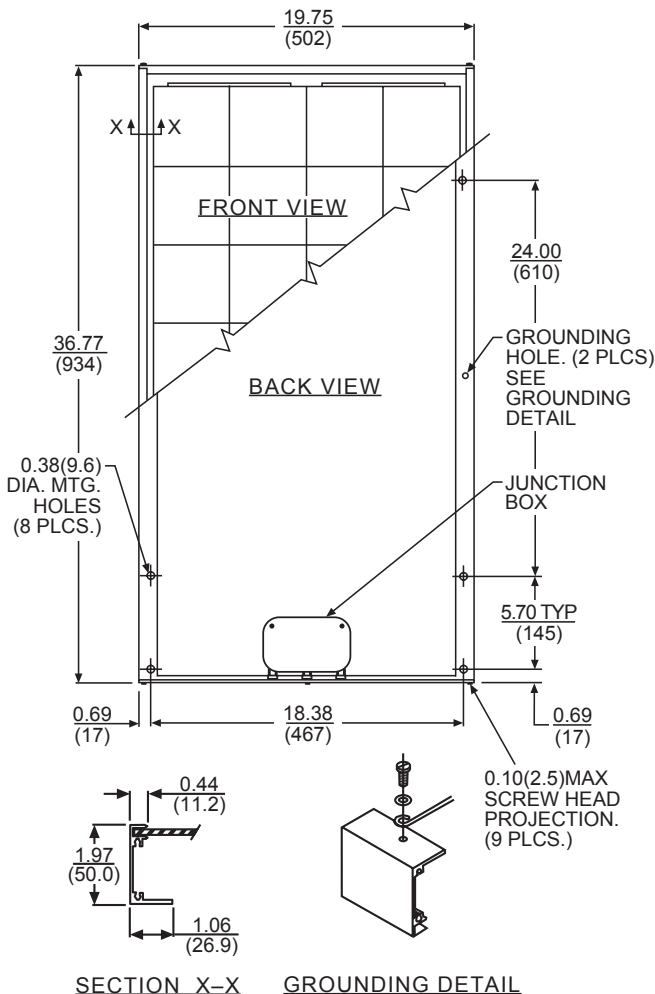

Typical Electrical Characteristics¹

Maximum power (P_{max})50W
Voltage at Pmax (V_{mp})17.1V
Current at Pmax (I_{mp})2.92A
Guaranteed minimum P_{max}47.5W
Short-circuit current (I_{sc})3.17A
Open-circuit voltage (V_{oc})21.1V
Temperature coefficient of I_{sc}(0.065±0.015)%/°C
Temperature coefficient of V_{oc}	-(80±10)mV/°C
Temperature coefficient of power	-(0.5±0.05)%/°C
NOCT ²47±2°C

Notes

(1) These modules are tested, labeled and shipped in 12V configuration. These data represent the performance of typical 12V modules as measured at their output terminals, and do not include the effect of such additional equipment as diodes and cabling. The data are based on measurements made in a solar simulator at Standard Test Conditions (STC), which are:

- illumination of 1 kW/m² (1 sun) at spectral distribution of AM 1.5;
- cell temperature of 25°C or as otherwise specified (on curves).

Operating characteristics in sunlight may differ slightly. For characteristics of modules in 6V configuration, divide the 12V voltage characteristics by 2 and multiply current characteristics by 2. Power values are unchanged.

(2) Under most climatic conditions, the cells in a module operate hotter than the ambient temperature. NOCT (Nominal Operating Cell Temperature) is an indicator of this temperature differential, and is the cell temperature under Standard Operating Conditions: ambient temperature of 20°C, solar irradiation of 0.8 kW/m², and wind speed of 1 m/s.

IV Characteristics

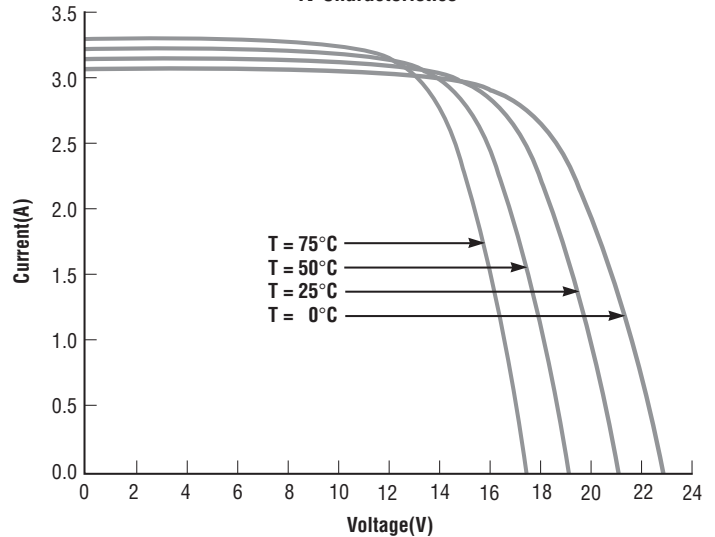

For more information, contact: