

# Thick Film Resistor Networks

## Single-In-Line, Molded SIP; 01, 03, 05 Schematics

### 6, 8, 9 or 10 Pin "A" Profile and 6, 8 or 10 Pin "C" Profile

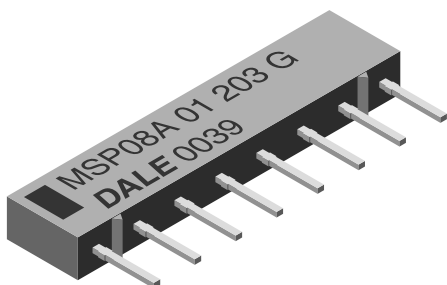

#### FEATURES

- 0.195" [4.95 mm] "A" or 0.350" [8.89 mm] "C" maximum seated height
- Thick film resistive elements
- Low temperature coefficient (- 55 °C to + 125 °C) ± 100 ppm/°C
- Rugged, molded case construction
- Reduces total assembly costs
- Compatible with automatic insertion equipment and reduces PC board space
- Wide resistance range (10 Ω to 2.2 MΩ)
- Available in tube pack or side-by-side pack
- Lead (Pb)-free version is RoHS compliant



**RoHS\***  
COMPLIANT

STANDARD ELECTRICAL SPECIFICATIONS							
GLOBAL MODEL/ SCHEMATIC	PROFILE	RESISTOR POWER RATING Max. AT 70 °C W	RESISTANCE RANGE Ω	STANDARD TOLERANCE %	TEMPERATURE COEFFICIENT (- 55 °C to + 125 °C) ppm/°C	TCR TRACKING* (- 55 °C to + 125 °C) ppm/°C	OPERATING VOLTAGE Max. VDC
MSPxxx01	A C	0.20 0.25	10 - 2.2M	± 2 Standard (1, 5)**	± 100	± 50 ppm/°C	100
MSPxxx03	A C	0.30 0.40	10 - 2.2M	± 2 Standard (1, 5)**	± 100	± 50 ppm/°C	100
MSPxxx05	A C	0.20 0.25	10 - 2.2M	± 2 Standard (± 5 %)**	± 100	± 150 ppm/°C	100

\* Tighter tracking available

\*\* Tolerances in brackets available on request

#### GLOBAL PART NUMBER INFORMATION

**New Global Part Numbering: MSP06A031K00GDA (preferred part numbering format)**

M	S	P	0	6	A	0	3	1	K	0	0	G	D	A			
GLOBAL MODEL MSP	PIN COUNT 06 = 6 Pin 08 = 8 Pin 09 = 9 Pin 10 = 10 Pin	PACKAGE HEIGHT A = "A" Profile C = "C" Profile	SCHEMATIC 01 = Bussed 03 = Isolated 00 = Special	RESISTANCE VALUE R = Decimal K = Thousand M = Million 10R0 = 10 Ω 680K = 680 kΩ 1M00 = 1.0 MΩ	TOLERANCE CODE F = ± 1 % G = ± 2 % J = ± 5 % S = Special	PACKAGING EJ = Lead (Pb)-free, Tube DA = Tin/Lead, Tube	SPECIAL Blank = Standard (Dash Number) (up to 3 digits) From 1-999 as applicable										

**Historical Part Number example: MSP06A03102G (will continue to be accepted)**

MSP	06	A	03	102	G	DO3
HISTORICAL MODEL	PIN COUNT	PACKAGE HEIGHT	SCHEMATIC	RESISTANCE VALUE	TOLERANCE CODE	PACKAGING

**New Global Part Numbering: MSP08C05131AGDA (preferred part numbering format)**

M	S	P	0	8	C	0	5	1	3	1	A	G	D	A			
GLOBAL MODEL MSP	PIN COUNT 06 = 6 Pin 08 = 8 Pin 09 = 9 Pin 10 = 10 Pin	PACKAGE HEIGHT A = "A" Profile C = "C" Profile	SCHEMATIC 05 = Dual Terminator	RESISTANCE VALUE 3 digit Impedance code, followed by Alpha modifier (see Impedance codes table)	TOLERANCE CODE F = ± 1 % G = ± 2 % J = ± 5 %	PACKAGING EJ = Lead (Pb)-free, Tube DA = Tin/Lead, Tube	SPECIAL Blank = Standard (Dash Number) (up to 3 digits) From 1-999 as applicable										

**Historical Part Number example: MSP08C05221331G (will continue to be accepted)**

MSP	08	C	05	221	331	G	DO3
HISTORICAL MODEL	PIN COUNT	PACKAGE HEIGHT	SCHEMATIC	RESISTANCE VALUE 1	RESISTANCE VALUE 2	TOLERANCE	PACKAGING

\* Pb containing terminations are not RoHS compliant, exemptions may apply



Thick Film Resistor Networks Single-In-Line, Molded SIP;  
01, 03, 05 Schematics 6, 8, 9 or 10 Pin "A" Profile  
and 6, 8 or 10 Pin "C" Profile

**DIMENSIONS** in inches [millimeters]

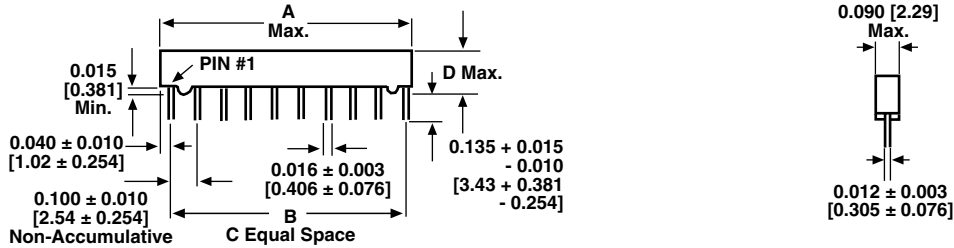

GLOBAL MODEL	A (Max.)	B	C	D (Max.)
MSP06	0.590 [14.99]	0.500 [12.70]	5	MSPxxA = 0.195 [4.95] MSPxxC = 0.350 [8.89]
MSP08	0.790 [20.07]	0.700 [17.78]	7	
MSP10	0.990 [25.15]	0.900 [22.86]	9	
MSP09	0.890 [22.61]	0.800 [20.32]	8	0.195 [4.95] ONLY

TECHNICAL SPECIFICATIONS		
PARAMETER	UNIT	MSP SERIES
Package Power Rating Maximum at + 25 °C and + 70 °C		See Derating Curves
Voltage Coefficient of Resistance	V <sub>eff</sub>	< 50 ppm typical
Dielectric Strength	VAC	200
Isolation Resistance (03 Schematic)	Ω	> 100M
Operating Temperature Range	°C	- 55 to + 125
Storage Temperature Range	°C	- 55 to + 150

MECHANICAL SPECIFICATIONS									
Marking Resistance to Solvents:	Permanency testing per MIL-STD-202, Method 215								
Solderability:	Per MIL-STD-202, Method 208E, RMA flux								
Body:	Molded epoxy								
Terminals:	Copper alloy, solder plated								
Weight:	<table border="0"> <tr> <td>MSP06A = 0.4 gram</td> <td>MSP06C = 0.7 gram</td> </tr> <tr> <td>MSP08A = 0.5 gram</td> <td>MSP08C = 0.9 gram</td> </tr> <tr> <td>MSP09A = 0.55 gram</td> <td>MSP10C = 1.1 gram</td> </tr> <tr> <td>MSP10A = 0.6 gram</td> <td></td> </tr> </table>	MSP06A = 0.4 gram	MSP06C = 0.7 gram	MSP08A = 0.5 gram	MSP08C = 0.9 gram	MSP09A = 0.55 gram	MSP10C = 1.1 gram	MSP10A = 0.6 gram	
MSP06A = 0.4 gram	MSP06C = 0.7 gram								
MSP08A = 0.5 gram	MSP08C = 0.9 gram								
MSP09A = 0.55 gram	MSP10C = 1.1 gram								
MSP10A = 0.6 gram									

IMPEDANCE CODES					
CODE	R <sub>1</sub> (Ω)	R <sub>2</sub> (Ω)	CODE	R <sub>1</sub> (Ω)	R <sub>2</sub> (Ω)
500B	82	130	141A	270	270
750B	120	200	181A	330	390
800C	130	210	191A	330	470
990A	160	260	221B	330	680
101C	180	240	281B	560	560
111C	180	270	381B	560	1.2K
121B	180	390	501C	620	2.7K
121C	220	270	102A	1.5K	3.3K
131A	220	330	202B	3K	6.2K

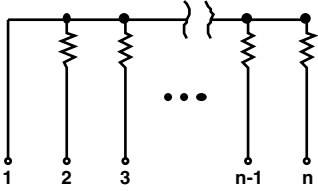
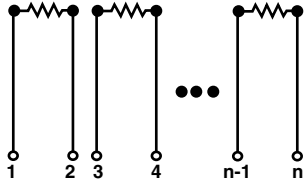
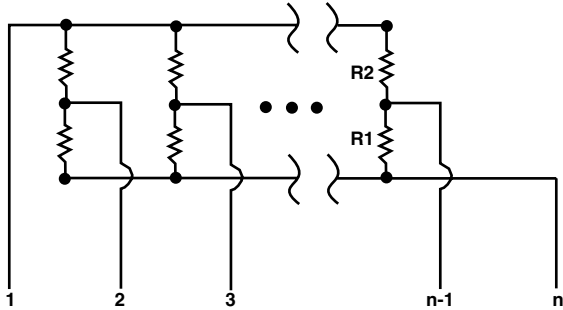
CIRCUIT APPLICATIONS	
<p><b>01 Schematic</b></p> 	<p>5, 7, 8* or 9 resistors with one pin common</p> <p>The MSPxxx01 circuit contains 5, 7, 8* or 9 nominally equal resistors, each connected between a common pin (Pin No. 1) and a discrete PC board pin. Commonly used in the following applications:</p> <ul style="list-style-type: none"> <li>• "Wired OR" Pull-up</li> <li>• Power Gate Pull-up</li> <li>• TTL Input Pull-down</li> <li>• MOS/ROM Pull-up/Pull-down</li> <li>• Open Collector Pull-up</li> <li>• TTL Unused Gate Pull-up</li> </ul> <p>* Available in "A" Profile only</p> <p>Standard E-24 resistance values stocked. Consult factory.</p>
<p><b>03 Schematic</b></p> 	<p>3, 4 or 5 isolated resistors</p> <p>The MSPxxx03 circuit contains 3, 4 or 5 resistors of nominally equal value in a compact package. Each resistor is connected to two discrete PC pins.</p> <p>Standard E-24 resistance values stocked. Consult factory.</p>
<p><b>05 Schematic</b></p> 	<p>Pulse squaring and TTL dual-line terminators</p> <p>The MSPxxx05 circuits contain 4, 6, 7* or 8 series pair of resistors. Each series pair is connected between two common lines. The junction of these resistor pairs is connected to the input terminals.</p> <p>The 05 circuits are designed for TTL dual-line termination and pulse squaring.</p> <p>* Available in "A" Profile only</p> <p>Many dual terminator resistance values stocked. Consult factory.</p>



Thick Film Resistor Networks Single-In-Line, Molded SIP;  
01, 03, 05 Schematics 6, 8, 9 or 10 Pin "A" Profile  
and 6, 8 or 10 Pin "C" Profile

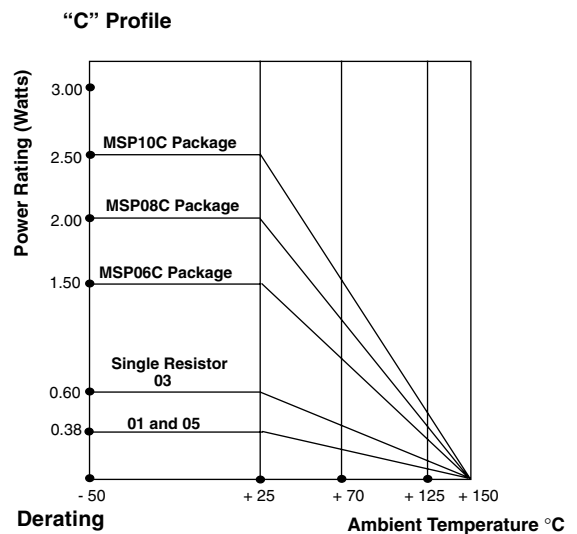
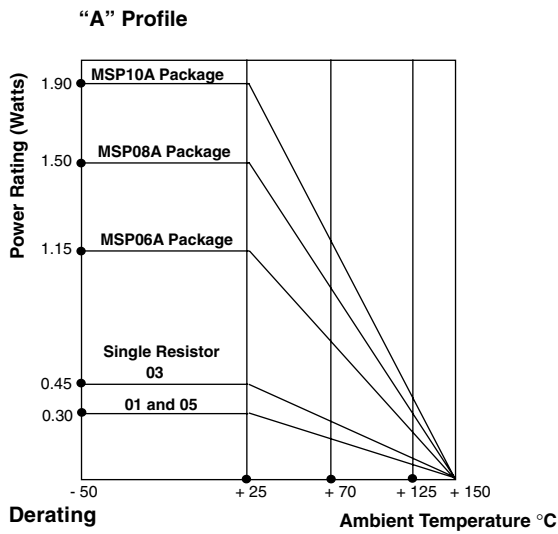

<b>"A" PROFILE + 70 °C PACKAGE RATINGS</b>	
MSP10A	1.25 watts
MSP09A	1.12 watts
MSP08A	1.00 watts
MSP06A	0.75 watts

<b>"C" PROFILE + 70 °C PACKAGE RATINGS</b>	
MSP10C	1.60 watts
MSP08C	1.30 watts
MSP06C	1.00 watts

Higher power ratings available. Contact factory.

<b>PERFORMANCE</b>		
TEST	CONDITIONS	MAX. ΔR (Typical Test Lots)
Power Conditioning	1.5 x rated power, applied 1.5 hours "ON" and 0.5 hour "OFF" for 100 hrs. ± 4 hrs. at + 25 °C ambient temperature	± 0.50 % ΔR
Thermal Shock	5 cycles between - 65 °C and + 125 °C	± 0.50 % ΔR
Short Time Overload	2.5 x rated working voltage 5 seconds	± 0.25 % ΔR
Low Temperature Operation	45 minutes at full rated working voltage at - 65 °C	± 0.25 % ΔR
Moisture Resistance	240 hrs. with humidity ranging from 80 % RH to 98 % RH	± 0.50 % ΔR
Resistance to Soldering Heat	Leads immersed in + 260 °C solder to within 1/16" of device body for 10 seconds	± 0.25 % ΔR
Shock	Total of 18 shocks at 100 G's	± 0.25 % ΔR
Vibration	12 hours at maximum of 20 G's between 10 and 2000 Hz	± 0.25 % ΔR
Load Life	1000 hrs. at + 70 °C, rated power applied 1.5 hours "ON", 0.5 hour "OFF" for full 1000 hour period. Derated according to the curve.	± 1.00 % ΔR
Terminal Strength	4.5 pound pull for 30 seconds	± 0.25 % ΔR
Insulation Resistance	10 000 Megohm (minimum)	-
Dielectric Withstanding Voltage		-



## Disclaimer

All product specifications and data are subject to change without notice.

Vishay Intertechnology, Inc., its affiliates, agents, and employees, and all persons acting on its or their behalf (collectively, "Vishay"), disclaim any and all liability for any errors, inaccuracies or incompleteness contained herein or in any other disclosure relating to any product.

Vishay disclaims any and all liability arising out of the use or application of any product described herein or of any information provided herein to the maximum extent permitted by law. The product specifications do not expand or otherwise modify Vishay's terms and conditions of purchase, including but not limited to the warranty expressed therein, which apply to these products.

No license, express or implied, by estoppel or otherwise, to any intellectual property rights is granted by this document or by any conduct of Vishay.

The products shown herein are not designed for use in medical, life-saving, or life-sustaining applications unless otherwise expressly indicated. Customers using or selling Vishay products not expressly indicated for use in such applications do so entirely at their own risk and agree to fully indemnify Vishay for any damages arising or resulting from such use or sale. Please contact authorized Vishay personnel to obtain written terms and conditions regarding products designed for such applications.

Product names and markings noted herein may be trademarks of their respective owners.