

Aluminum Capacitors Power Printed Wiring Style

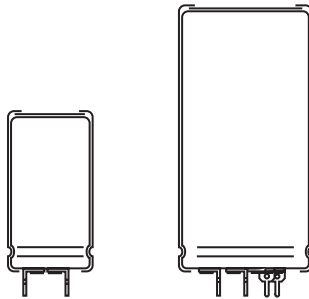

Component outlines

RoHS
COMPLIANT

FEATURES

- Polarized aluminum electrolytic capacitors, non-solid electrolyte
- Large types, minimized dimensions, cylindrical aluminum case, insulated with a blue sleeve
- Provided with keyed polarity
- Very long useful life: 5000 h at 105 °C
- Low ESR, high ripple current capability
- Temperature range up to 105 °C
- High resistance to shock and vibration

APPLICATIONS

- Computer, telecommunication and industrial systems
- Smoothing and filtering
- Standard and switched mode power supplies
- Energy storage in pulse systems

MARKING

The capacitors are marked (where possible) with the following information:

- Rated capacitance (in μF)
- Tolerance on rated capacitance, code letter in accordance with IEC 60062 (M for $\pm 20\%$)
- Rated voltage (in V)
- Date code (YYMM)
- Name of manufacturer
- Code for factory of origin
- Polarity of the terminals and '-' sign to indicate the negative terminal, visible from the top and/or side of the capacitor
- Code number
- Climatic category in accordance with IEC 60068

QUICK REFERENCE DATA

DESCRIPTION	VALUE
Nominal case size ($\varnothing D \times L$ in mm)	25 x 30 to 40 x 100
Rated capacitance range (E6 series), C_R	470 μF to 150 000 μF 68 μF to 3300 μF
Tolerance on C_R	$\pm 20\%$
Rated voltage range, U_R	10 V to 100 V 200 V to 400 V
Category temperature range	- 40 °C to + 105 °C
Endurance test at 105 °C	2000 h
Useful life at 105 °C	5000 h
Useful life at 40 °C, $1.9 \times I_R$ applied	150 000 h
Shelf life at 0 V, 105 °C	500 h
Based on sectional specification	IEC 60384-4/EN130300
Climatic category IEC 60068	40/105/56

SELECTION CHART FOR C_R , U_R AND RELEVANT NOMINAL CASE SIZES ($\varnothing D \times L$ in mm)

C_R (μF)	U_R (V)					
	10	16	25	40	63	100
470	-	-	-	-	-	25 x 30
680	-	-	-	-	-	25 x 40
1000	-	-	-	-	25 x 30	30 x 40
1500	-	-	-	-	25 x 40	35 x 40
2200	-	-	-	25 x 30	30 x 40	35 x 50
	-	-	-	-	-	40 x 40
3300	-	-	-	25 x 40	35 x 40	40 x 50
4700	-	-	25 x 30	30 x 40	35 x 50	40 x 70
	-	-	-	-	40 x 40	-
6800	-	25 x 30	25 x 40	35 x 40	40 x 50	40 x 100
10 000	25 x 30	25 x 40	30 x 40	35 x 50	40 x 70	-
	-	-	-	40 x 40	-	-
15 000	25 x 40	30 x 40	35 x 40	40 x 50	40 x 100	-
	30 x 40	35 x 40	35 x 50	40 x 70	-	-
22 000	-	-	40 x 40	-	-	-
	35 x 40	35 x 50	40 x 50	40 x 100	-	-
	-	40 x 40	-	-	-	-
33 000	35 x 40	35 x 50	40 x 50	40 x 100	-	-
	-	40 x 40	-	-	-	-
47 000	35 x 50	40 x 50	40 x 70	-	-	-
	40 x 40	-	-	-	-	-
68 000	40 x 50	40 x 70	40 x 100	-	-	-
100 000	40 x 70	40 x 100	-	-	-	-
150 000	40 x 100	-	-	-	-	-

SELECTION CHART FOR C_R, U_R AND RELEVANT NOMINAL CASE SIZES ($\varnothing D \times L$ in mm)				
C_R (μF)	U_R (V)			
	200	250	385	400
68	-	-	25 x 30	25 x 30
100	-	25 x 30	25 x 40	25 x 40
150	25 x 30	25 x 40	30 x 40	30 x 40
220	25 x 40	30 x 40	35 x 40	35 x 40
330	30 x 40	35 x 40	35 x 50	35 x 50
	-	-	40 x 40	40 x 40
470	35 x 40	35 x 50	40 x 50	40 x 50
	-	40 x 40	-	-
680	35 x 50	40 x 50	40 x 70	40 x 70
	40 x 50	-	-	-
1000	40 x 50	40 x 70	40 x 100	40 x 100
1500	40 x 70	40 x 100	-	-
2200	40 x 100	-	-	-

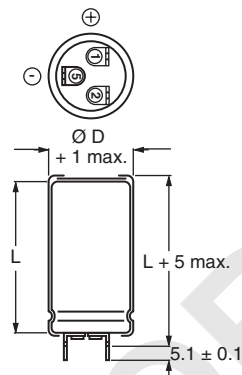
DIMENSIONS in millimeters AND AVAILABLE FORMS

1 = Positive terminal
 5 = Negative terminal
 Case $\varnothing D = 25$ mm

Fig.1 Printed wiring pin version

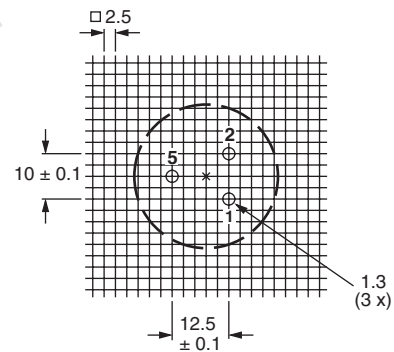

Case $\varnothing D = 25$ mm

Fig.2 Mounting hole pattern viewed from the component side

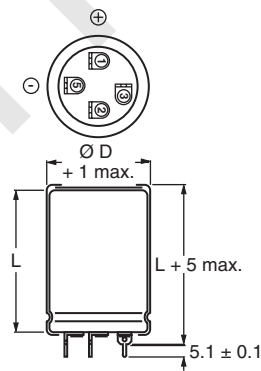

1 = Positive terminal
 5 = Negative terminal
 Case $\varnothing D = 30$ mm and 35 mm

Fig.3 Printed wiring pin version

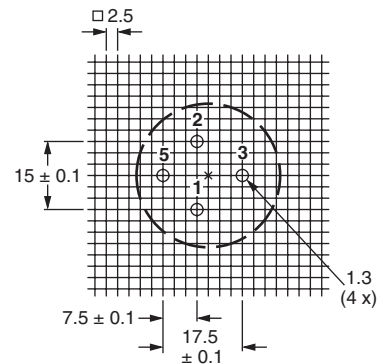

Case $\varnothing D = 30$ mm and 35 mm

Fig.4 Mounting hole pattern viewed from the component side

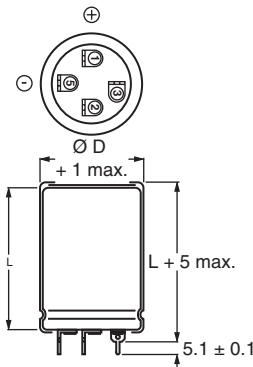

1 = Positive terminal;
5 = Negative terminal
Case Ø D = 35 mm

Fig.5 Printed wiring pin version

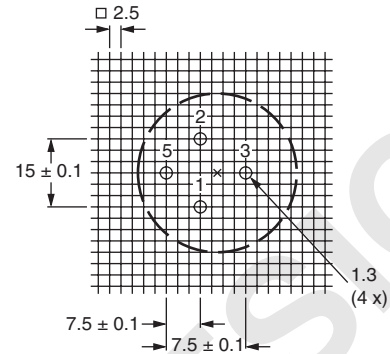

Case Ø D = 35 mm

Fig.6 Mounting hole pattern viewed from the component side

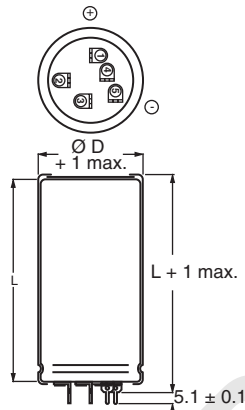

1 = Positive terminal;
5 = Negative terminal
Case Ø D = 40 mm

Fig.7 Printed wiring pin version

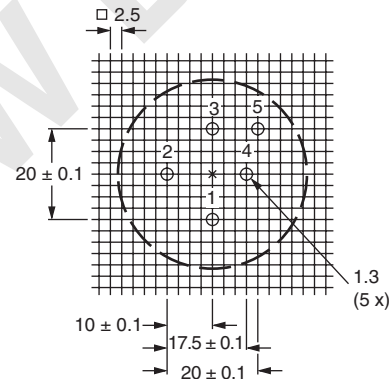

Case Ø D = 40 mm

Fig.8 Mounting hole pattern viewed from the component side

DIMENSIONS in millimeters, MASS AND PACKAGING QUANTITIES PW versions					
NOMINAL CASE SIZE Ø D x L	Ø D _{max.}	L _{max.}	MASS (g)	PACKAGING QUANTITIES (units per box)	CARDBOARD BOX DIMENSIONS L x W x H
25 x 30	26	35	≈ 24	100	290 x 280 x 50
25 x 40	26	45	≈ 28	100	290 x 280 x 60
30 x 40	31	45	≈ 38	100	340 x 330 x 60
35 x 40	36	45	≈ 51	50	390 x 198 x 60
35 x 50	36	55	≈ 66	50	390 x 198 x 70
40 x 40	41	45	≈ 78	50	440 x 223 x 60
40 x 50	41	55	≈ 82	50	440 x 223 x 70
40 x 70	41	75	≈ 110	25	230 x 230 x 90
40 x 100	41	105	≈ 176	25	230 x 230 x 120

MOUNTING

When a number of capacitors are connected in a bank, they must not be closer together than 15 mm, when no derating of ripple current and/or temperature is applied.

Pin numbers 2, 3 and 4 (if present) must be free from the electrical circuit.



Aluminum Capacitors
Power Printed Wiring Style

Vishay Roederstein

ELECTRICAL DATA	
SYMBOL	DESCRIPTION
C _R	rated capacitance at 100 Hz
I _R	rated RMS ripple current at 100 Hz and 105 °C
I _{L1}	max. leakage current after 1 minute at U _R
I _{L5}	max. leakage current after 5 minutes at U _R
ESR	max. equivalent series resistance at 100 Hz
Z	max. impedance at 10 kHz

ORDERING EXAMPLE

10 000 µF/25 V; ± 20 %

Nominal case size: Ø 30 x 40 mm

Ordering code: MALPEYZ00BB510E02W

Note

(1) Unless otherwise specified, all electrical values in Tables 2 and 3 apply at T_a = 20 °C, P = 86 kPa to 106 kPa, RH = 45 % to 75 %

ELECTRICAL DATA AND ORDERING INFORMATION								
U _R (V)	C _R 100 Hz (µF)	NOMINAL CASE SIZE Ø D x L (mm)	I _R 100 Hz 105 °C (A)	I _{L1} 1 min (mA)	I _{L5} 5 min (mA)	ESR 100 Hz (mΩ)	Z 10 kHz (mΩ)	ORDERING CODE
10	10 000	25 x 30	3.17	0.60	0.20	48	37	MALPEYZ00AV510C02W
	15 000	25 x 40	4.21	0.90	0.30	34	27	MALPEYZ00AB515C02W
	22 000	30 x 40	5.05	1.32	0.44	29	23	MALPEYZ00BB522C02W
	33 000	35 x 40	5.63	1.98	0.66	27	22	MALPEYZ00CB533C02W
	47 000	35 x 50	6.19	2.82	0.94	26	21	MALPEYZ00CD547C02W
	47 000	40 x 40	6.19	2.82	0.94	26	21	MALPEYZ00DB547C02W
	68 000	40 x 50	7.64	4.08	1.36	21	18	MALPEYZ00DD568C02W
	100 000	40 x 70	10.0	6.00	2.00	16	15	MALPEYZ00DG610C02W
	150 000	40 x 100	12.9	9.00	3.00	13	12	MALPEYZ00DM615C02W
16	6800	25 x 30	3.11	0.65	0.22	50	37	MALPEYZ00AV468D02W
	10 000	25 x 40	4.09	0.96	0.32	36	27	MALPEYZ00AB510D02W
	15 000	30 x 40	4.97	1.44	0.48	30	23	MALPEYZ00BB515D02W
	22 000	35 x 40	5.53	2.12	0.71	29	22	MALPEYZ00CB522D02W
	33 000	35 x 50	6.08	3.17	1.06	28	21	MALPEYZ00CD533D02W
	33 000	40 x 40	6.08	3.17	1.06	28	21	MALPEYZ00DB533D02W
	47 000	40 x 50	7.46	4.52	1.51	22	18	MALPEYZ00DD547D02W
	68 000	40 x 70	9.70	6.53	2.18	17	15	MALPEYZ00DG568D02W
	100 000	40 x 100	12.90	9.60	3.20	13	12	MALPEYZ00DM610D02W
25	4700	25 x 30	2.94	0.71	0.24	56	37	MALPEYZ00AV447E02W
	6800	25 x 40	3.93	1.02	0.34	39	27	MALPEYZ00AB468E02W
	10 000	30 x 40	4.81	1.50	0.50	32	23	MALPEYZ00BB510E02W
	15 000	35 x 40	5.43	2.25	0.75	30	22	MALPEYZ00CB515E02W
	22 000	35 x 50	5.98	3.30	1.10	29	21	MALPEYZ00CD522E02W
	22 000	40 x 40	5.98	3.30	1.10	29	21	MALPEYZ00DB522E02W
	33 000	40 x 50	7.30	4.95	1.65	23	18	MALPEYZ00DD533E02W
	47 000	40 x 70	9.43	7.05	2.35	18	15	MALPEYZ00DG547E02W
	68 000	40 x 100	12.44	10.20	3.40	14	12	MALPEYZ00DM568E02W
40	2200	25 x 30	2.36	0.53	0.18	87	54	MALPEYZ00AV422G02W
	3300	25 x 40	3.17	0.79	0.27	60	38	MALPEYZ00AB423G02W
	4700	30 x 40	3.93	1.13	0.38	48	33	MALPEYZ00BB447G02W
	6800	35 x 40	4.59	1.63	0.55	42	31	MALPEYZ00CB468G02W
	10 000	35 x 50	5.03	2.40	0.80	41	29	MALPEYZ00CD510G02W
	10 000	40 x 40	5.03	2.40	0.80	41	29	MALPEYZ00DB510G02W
	15 000	40 x 50	6.09	3.60	1.20	33	24	MALPEYZ00DD515G02W
	22 000	40 x 70	8.34	5.28	1.76	23	18	MALPEYZ00DG522G02W
	33 000	40 x 100	10.97	7.92	2.64	18	15	MALPEYZ00DM533G02W
63	1000	25 x 30	1.55	0.38	0.13	202	155	MALPEYZ00AV410J02W
	1500	25 x 40	2.10	0.57	0.19	137	109	MALPEYZ00AB415J02W
	2200	30 x 40	2.72	0.83	0.28	100	79	MALPEYZ00BB422J02W
	3300	35 x 40	3.44	1.25	0.42	75	61	MALPEYZ00CB433J02W
	4700	35 x 50	4.09	1.78	0.60	62	53	MALPEYZ00CD447J02W
	4700	40 x 40	4.09	1.78	0.60	62	53	MALPEYZ00DB447J02W
	6800	40 x 50	5.10	2.57	0.86	47	40	MALPEYZ00DD468J02W
	10 000	40 x 70	6.86	3.78	1.26	34	29	MALPEYZ00DG510J02W
	15 000	40 x 100	9.31	5.67	1.89	25	21	MALPEYZ00DM515J02W

ELECTRICAL DATA AND ORDERING INFORMATION								
U_R (V)	C_R 100 Hz (μ F)	NOMINAL CASE SIZE \varnothing D x L (mm)	I_R 100 Hz 105 °C (A)	I_{L1} 1 min (mA)	I_{L5} 5 min (mA)	ESR 100 Hz (m Ω)	Z 10 kHz (m Ω)	ORDERING CODE
100	470	25 x 30	1.42	0.28	0.10	240	155	MALPEYZ00AV347L02W
	680	25 x 40	1.90	0.41	0.14	167	109	MALPEYZ00AB368L02W
	1000	30 x 40	2.48	0.60	0.20	120	79	MALPEYZ00BB410L02W
	1500	35 x 40	3.17	0.90	0.30	88	61	MALPEYZ00CB415L02W
	2200	35 x 50	3.79	1.32	0.44	72	53	MALPEYZ00CD422L02W
	2200	40 x 40	3.79	1.32	0.44	72	53	MALPEYZ00DB422L02W
	3300	40 x 50	4.81	1.98	0.66	53	40	MALPEYZ00DD433L02W
	4700	40 x 70	6.49	2.82	0.94	38	29	MALPEYZ00DG447L02W
	6800	40 x 100	8.80	4.08	1.36	28	21	MALPEYZ00DM468L02W
200	150	25 x 30	0.72	0.18	0.06	950	710	MALPEYZ00AV315S02W
	220	25 x 40	0.96	0.26	0.09	650	485	MALPEYZ00AB322S02W
	330	30 x 40	1.29	0.40	0.14	442	330	MALPEYZ00BB333S02W
	470	35 x 40	1.66	0.57	0.19	321	240	MALPEYZ00CB347S02W
	680	35 x 50	2.09	0.82	0.28	237	185	MALPEYZ00CD368S02W
	680	40 x 40	2.09	0.82	0.28	237	185	MALPEYZ00DB368S02W
	1000	40 x 50	2.71	1.20	0.40	167	133	MALPEYZ00DD410S02W
	1500	40 x 70	3.75	1.80	0.60	114	90	MALPEYZ00DG415S02W
	2200	40 x 100	5.24	2.64	0.88	79	62	MALPEYZ00DM422S02W
250	100	25 x 30	0.67	0.15	0.05	1060	710	MALPEYZ00AV310N02W
	150	25 x 40	0.92	0.22	0.08	710	485	MALPEYZ00AB315N02W
	220	30 x 40	1.28	0.33	0.11	492	330	MALPEYZ00BB322N02W
	330	35 x 40	1.65	0.49	0.17	325	240	MALPEYZ00CB333N02W
	470	35 x 50	2.01	0.70	0.24	256	185	MALPEYZ00CD347N02W
	470	40 x 40	2.01	0.70	0.24	256	185	MALPEYZ00DB347N02W
	680	40 x 50	2.59	1.02	0.34	182	133	MALPEYZ00DD368N02W
	1000	40 x 70	3.58	1.50	0.50	125	90	MALPEYZ00DG410N02W
	1500	40 x 100	5.05	2.25	0.75	85	62	MALPEYZ00DM415N02W
385	68	25 x 30	0.61	0.16	0.06	1650	1260	MALPEYZ00AV268R02W
	100	25 x 40	0.82	0.23	0.08	1120	855	MALPEYZ00AB310R02W
	150	30 x 40	1.10	0.35	0.12	755	580	MALPEYZ00BB315R02W
	220	35 x 40	1.44	0.51	0.17	525	405	MALPEYZ00CB322R02W
	330	35 x 50	1.84	0.77	0.26	360	280	MALPEYZ00CD333R02W
	330	40 x 40	1.84	0.77	0.26	360	280	MALPEYZ00DB333R02W
	470	40 x 50	2.37	1.09	0.36	260	205	MALPEYZ00DD347R02W
	680	40 x 70	3.24	1.58	0.53	180	140	MALPEYZ00DG368R02W
	1000	40 x 100	4.54	2.31	0.78	125	100	MALPEYZ00DM410R02W
400	68	25 x 30	0.39	0.16	0.06	3200	2660	MALPEYZ00AV268X02W
	100	25 x 40	0.53	0.24	0.08	2180	1810	MALPEYZ00AB310X02W
	150	30 x 40	0.72	0.36	0.12	1460	1210	MALPEYZ00BB315X02W
	220	35 x 40	0.94	0.52	0.17	1010	830	MALPEYZ00CB322X02W
	330	35 x 50	1.24	0.79	0.26	680	570	MALPEYZ00CD333X02W
	330	40 x 40	1.24	0.79	0.26	680	570	MALPEYZ00DB333X02W
	470	40 x 50	1.59	1.12	0.37	485	407	MALPEYZ00DD347X02W
	680	40 x 70	2.18	1.63	0.54	336	282	MALPEYZ00DG368X02W
	1000	40 x 100	3.07	2.40	0.80	230	193	MALPEYZ00DM410X02W

ADDITIONAL ELECTRICAL DATA		
PARAMETER	CONDITIONS	VALUE
Voltage		
Surge voltage	≤ 200 V versions	$U_s = 1.15 \times U_R$
	≥ 385 V versions	$U_s = 1.1 \times U_R$
Reverse voltage		$U_{rev} \leq 1 \text{ V}$
Current		
Leakage current	After 1 minute at U_R	$I_{L1} \leq 0.006 C_R \times U_R + 4 \mu\text{A}$
	After 5 minutes at U_R	$I_{L5} \leq 0.002 C_R \times U_R + 4 \mu\text{A}$
Inductance		
Equivalent series inductance (ESL)	Case \varnothing D = 25 mm	max. 25 nH
	Case \varnothing D = 30 and 35 mm	max. 30 nH
	Case \varnothing D = 40 mm	max. 35 nH

RIPPLE CURRENT AND USEFUL LIFE

Fig.9 Multiplier of useful life as a function of ambient temperature and ripple current load

MULTIPLIER OF RIPPLE CURRENT (I_R) AS A FUNCTION OF FREQUENCY			
FREQUENCY (Hz)	I_R MULTIPLIER		
	$U_R = 10\text{ V to }25\text{ V}$	$U_R = 40\text{ V to }100\text{ V}$	$U_R = 200\text{ V to }400\text{ V}$
50	0.93	0.91	0.86
100	1.00	1.00	1.00
200	1.04	1.05	1.13
400	1.07	1.09	1.21
1000	1.11	1.13	1.29
2000	1.13	1.15	1.32
4000	1.15	1.18	1.35
≥ 10 000	1.18	1.22	1.40

TEST PROCEDURES AND REQUIREMENT			
TEST		PROCEDURE (quick reference)	REQUIREMENTS
NAME OF TEST	REFERENCE		
Endurance	IEC 60384-4/ EN130300 subclause 4.13	$T_a = 105\text{ }^\circ\text{C}$; U_R applied; 2000 h	$U_R \leq 100\text{ V}$; $\Delta C/C: \pm 15\%$ $U_R > 100\text{ V}$; $\Delta C/C: \pm 10\%$ $ESR \leq 1.3 \times \text{spec. limit}$ $Z \leq 2 \times \text{spec. limit}$ $I_{L5} \leq \text{spec. limit}$
Useful life	CECC 30301 subclause 1.8.1	$T_a = 105\text{ }^\circ\text{C}$; U_R and I_R applied; 5000 h	$U_R \leq 100\text{ V}$; $\Delta C/C: \pm 45\%$ $U_R > 100\text{ V}$; $\Delta C/C: \pm 30\%$ $ESR \leq 3 \times \text{spec. limit}$ $Z \leq 3 \times \text{spec. limit}$ $I_{L5} \leq \text{spec. limit}$ no short or open circuit, no visible damage total failure percentage: $U_R \leq 100\text{ V}: \leq 1\%$; $U_R > 100\text{ V}: \leq 3\%$
Shelf life (storage at high temperature)	IEC 60384-4/ EN130300 subclause 4.17	$T_a = 105\text{ }^\circ\text{C}$; no voltage applied; 500 h After test: U_R to be applied for 30 min, 24 to 48 h before measurement	$\Delta C/C: \pm 10\%$ $ESR \leq 1.2 \times \text{spec. limit}$ $I_{L5} \leq 2 \times \text{spec. limit}$

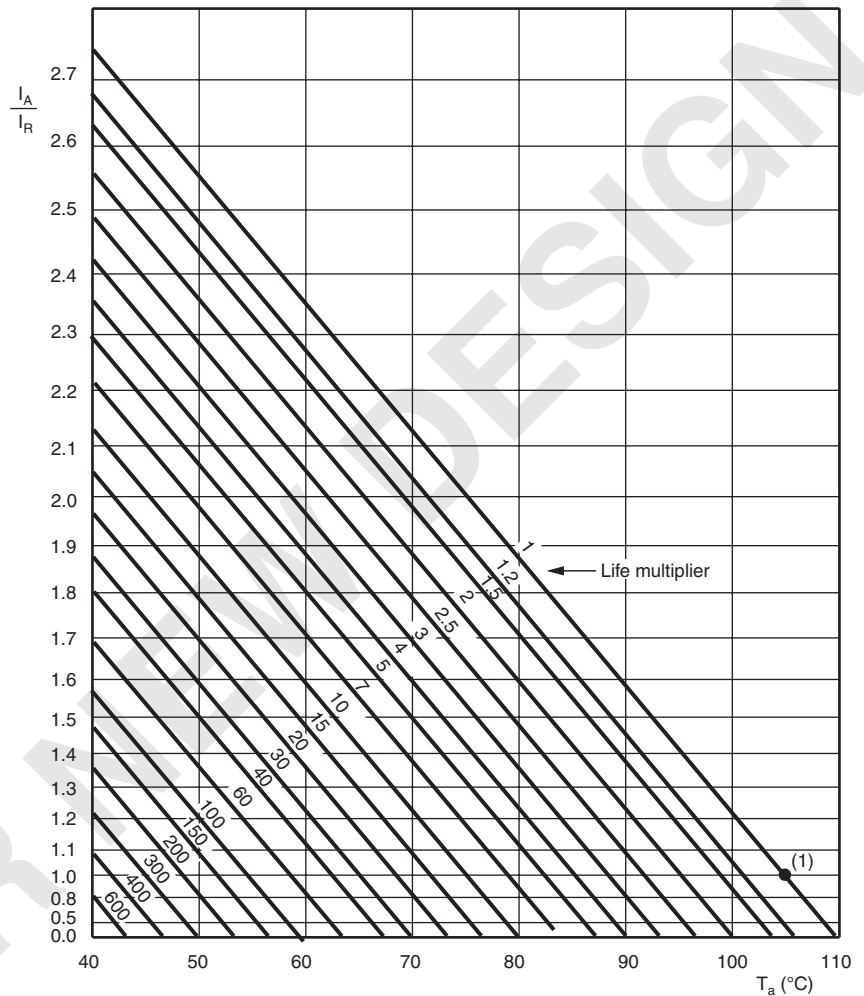

Disclaimer

All product specifications and data are subject to change without notice.

Vishay Intertechnology, Inc., its affiliates, agents, and employees, and all persons acting on its or their behalf (collectively, "Vishay"), disclaim any and all liability for any errors, inaccuracies or incompleteness contained herein or in any other disclosure relating to any product.

Vishay disclaims any and all liability arising out of the use or application of any product described herein or of any information provided herein to the maximum extent permitted by law. The product specifications do not expand or otherwise modify Vishay's terms and conditions of purchase, including but not limited to the warranty expressed therein, which apply to these products.

No license, express or implied, by estoppel or otherwise, to any intellectual property rights is granted by this document or by any conduct of Vishay.

The products shown herein are not designed for use in medical, life-saving, or life-sustaining applications unless otherwise expressly indicated. Customers using or selling Vishay products not expressly indicated for use in such applications do so entirely at their own risk and agree to fully indemnify Vishay for any damages arising or resulting from such use or sale. Please contact authorized Vishay personnel to obtain written terms and conditions regarding products designed for such applications.

Product names and markings noted herein may be trademarks of their respective owners.