

Description

The YB1300 is a switched capacitor DC/DC step up converter that produces a regulated 5V output. The input voltage range is from 2.7V to 5.0V that makes the YB1300 ideally for a single cell Li-Ion battery source.

The YB1300 works well for step-up applications without the need for an inductor. The 1MHz switching frequency allows the use of small SMD capacitors. The YB1300 provides thermal protection, short-circuit current limit protection. In order to prevent in-rush current effectively, it provides automatic soft-start. The quiescent current is 30µA without load and its shutdown current is less than 0.1µA. The YB1300 is available in a 6-pin SOT23 package.

Features

- Switched-Capacitor Step-Up Operation
- Input Range : 2.7V to 5.0V
- Output Voltage : 5V
- Output Current : 2.7V $V_{IN} < 3.2V$, $I_{OUT} 30mA$
- Output Current : 3.2V $V_{IN} < 5V$, $I_{OUT} 100mA$
- Shutdown Mode
- Low Quiescent Current : ~30µA
- 1MHz Internal Oscillator
- Thermal Protection Shutdown
- Output Short-circuit Current Limit Protection
- Automatic Soft-Start Reduces In-Rush Current
- SOT23-6 Package

Applications

- Cellular Phones
- White LED Drivers
- Smart Card Reader
- PCMCIA Cards
- Li-Ion Battery Backup Supplies

Typical Application Circuit

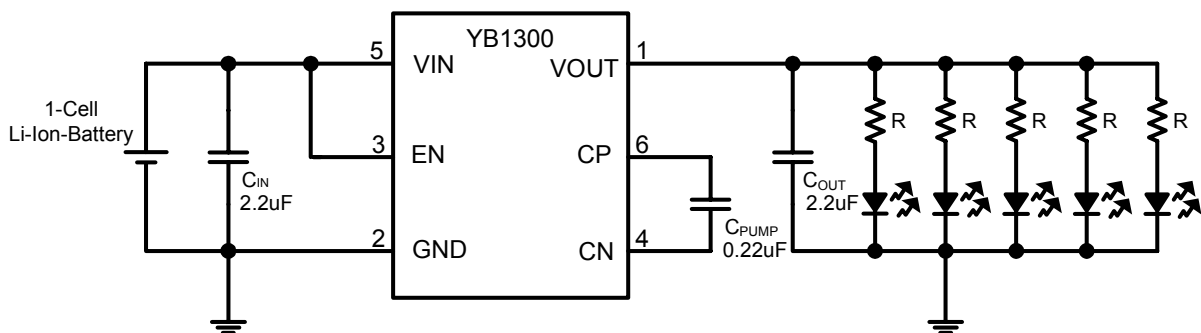

Figure 1. Typical application circuit

Pin Configuration

SOT23-6

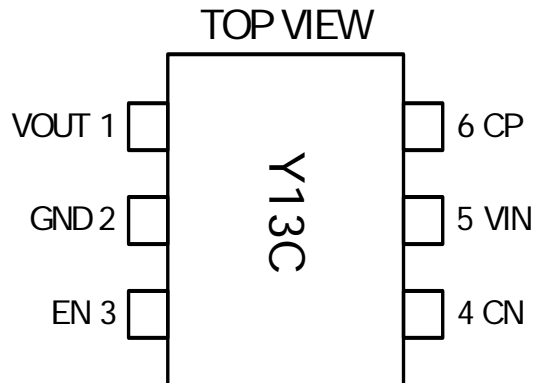

Figure 2. Pin configuration

Pin Description

Table 1

Pin	Name	Description
1	V_{OUT}	Regulated output voltage. V_{OUT} should be bypassed with a low ESR capacitor for the best performance.
2	GND	Ground pin.
3	EN	3V or above will turn on the IC. Below 0.4V will put the chip in the shutdown mode.
4	CN	Pumping capacitor negative terminal.
5	V_{IN}	Input supply voltage. V_{IN} should be bypassed with a 2.2 μ F low ESR capacitor.
6	CP	Pumping capacitor positive terminal.

Ordering Information

Order Number	Package Type	Supplied as	Package Marking
YB1300	SOT23-6	3000 units Tape & Reel	Y13C

Absolute Maximum Ratings

Supply Voltage.....5.5V
 Output Voltage.....5.5V
 Output Short-Circuit Duration Continuous
 Junction Temperature Range..... +125
 Storage Temperature Range -65 to +150
 Lead Temperature..... +250

Recommended Operating Conditions

Input Supply Voltage..... 2V to 5V
 Operating Temperature..... -40 to +85

Electrical Characteristics

At $T_A=25$, $V_{IN}=3.2V$, $I_{OUT}=10mA$, $C_{IN}=C_{OUT}=2.2\mu F$, $C_{PUMP}=0.22\mu F$, $V_{ENABLE}=V_{IN}$, unless otherwise noted.

Table 2

Symbol	Function Parameter	Test Conditions	Min	Typ	Max	Units
V_{IN}	Input Voltage		2.7		5.0	V
V_{OUT}	Output Voltage	2.7V $V_{IN} < 3.2V$, $I_{OUT} = 30mA$	4.7	5.0	5.3	V
		3.2V $V_{IN} < 5V$, $I_{OUT} = 100mA$	4.7	5.0	5.3	V
I_{OUT}	Output Current	$V_{IN}=3V$		100		mA
I_{SC}	Output Current (short-circuit)	$V_{IN}=3.2V$		210		mA
F_{OSC}	Oscillator Frequency			1		MHz
η	Efficiency	$I_{OUT} = 20mA$, $V_{IN}=2.7V$		88		%
V_R	Ripple Voltage	$V_{IN}=3.0V$, $I_{OUT} = 100mA$		50		mVpp
V_{IH}	Enable Control (High)	$V_{in}=3.3V$ to 5.0V	3		V_{IN}	V
V_{IL}	Enable Control (Low)	$V_{in}=3.3V$ to 5.0V	-0.2		0.4	V
T_{ST}	Thermal Shutdown	Shutdown Temperature		~160		
T_{RT}	Thermal Recovery	Recovery Temperature		~140		
I_{QC}	Supply Current (Quiescent)	$I_{OUT} = 0mA$		~30		μA
I_{SD}	Supply Current (Shutdown)	$V_{IN} = 2.7-5.0V$, Enable=0V		~0.0		μA
				1		

Note:

Typical Characteristics

At $T_A=25$, $V_{IN}=3.2V$, $I_{OUT}=10mA$, $C_{IN}=C_{OUT}=2.2\mu F$, $C_{PUMP}=0.22\mu F$, $V_{ENABLE}=V_{IN}$, unless otherwise noted.

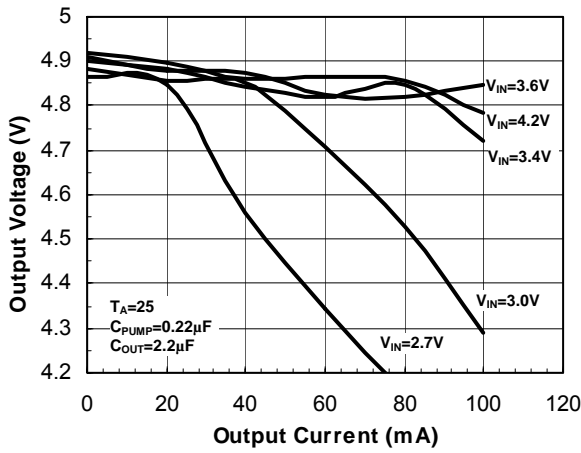

Fig3. Load Regulation

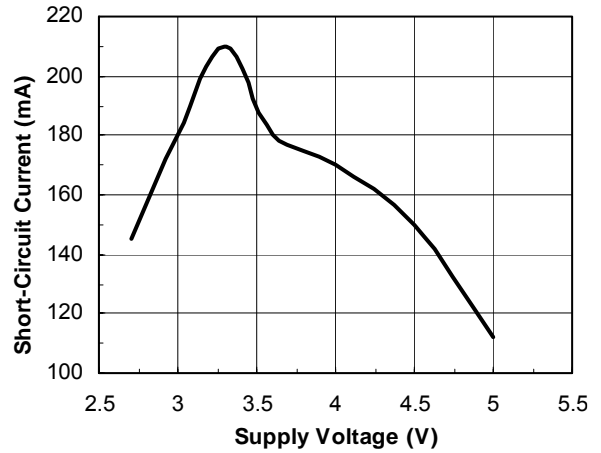

Fig6. Short-Circuit Current vs. Supply Voltage

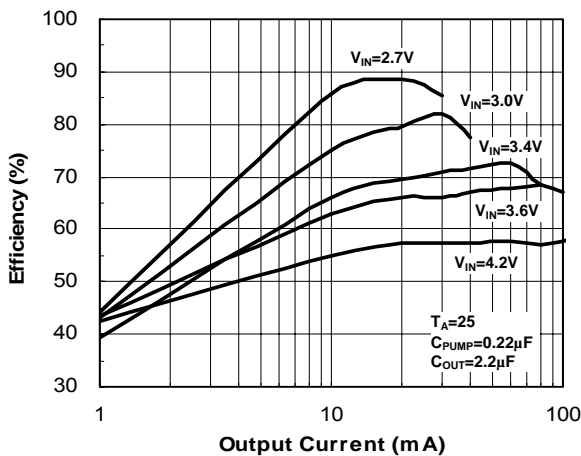

Fig4. Efficiency

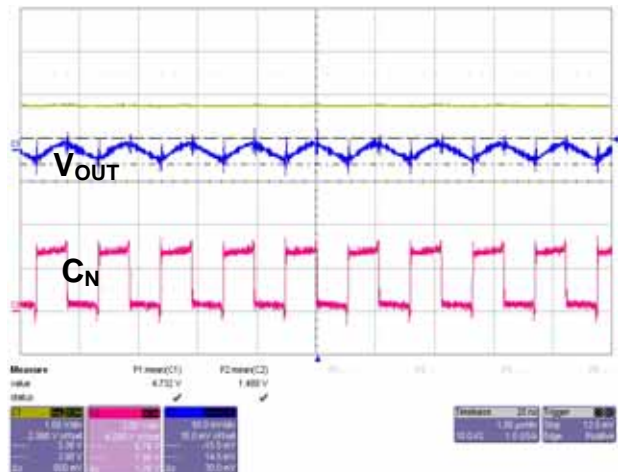

Fig7. Output Ripple
 $V_{IN}=3.6V$, $I_{OUT}=60mA$, $C_{OUT}=2.2\mu F$, $C_{PUMP}=0.22\mu F$

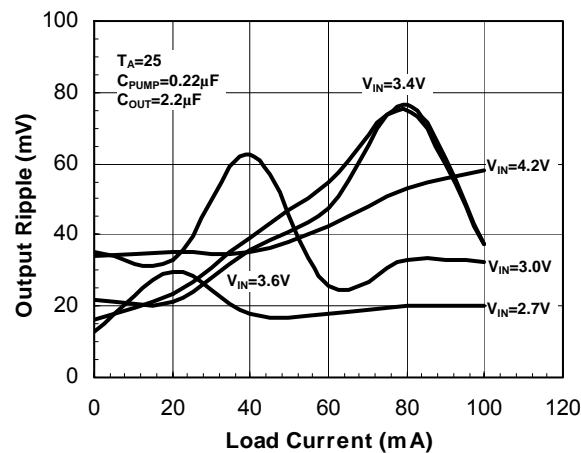

Fig5. Output Current vs. Output Ripple

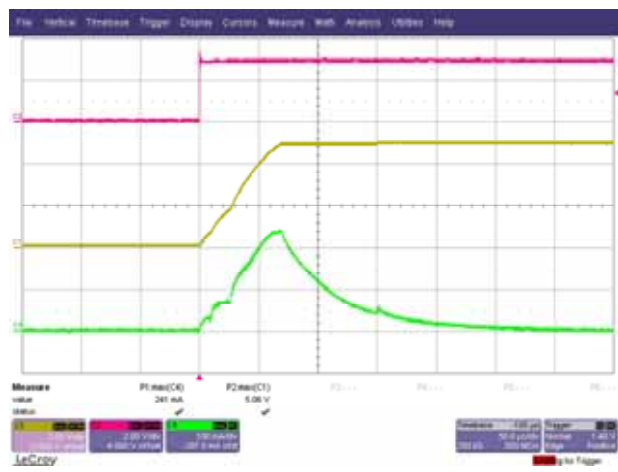

Fig8. Start-Up Time and In-Rush Current
 $V_{IN}=3.0V$, $I_{OUT}=0mA$, $C_{OUT}=2.2\mu F$

Functional Block

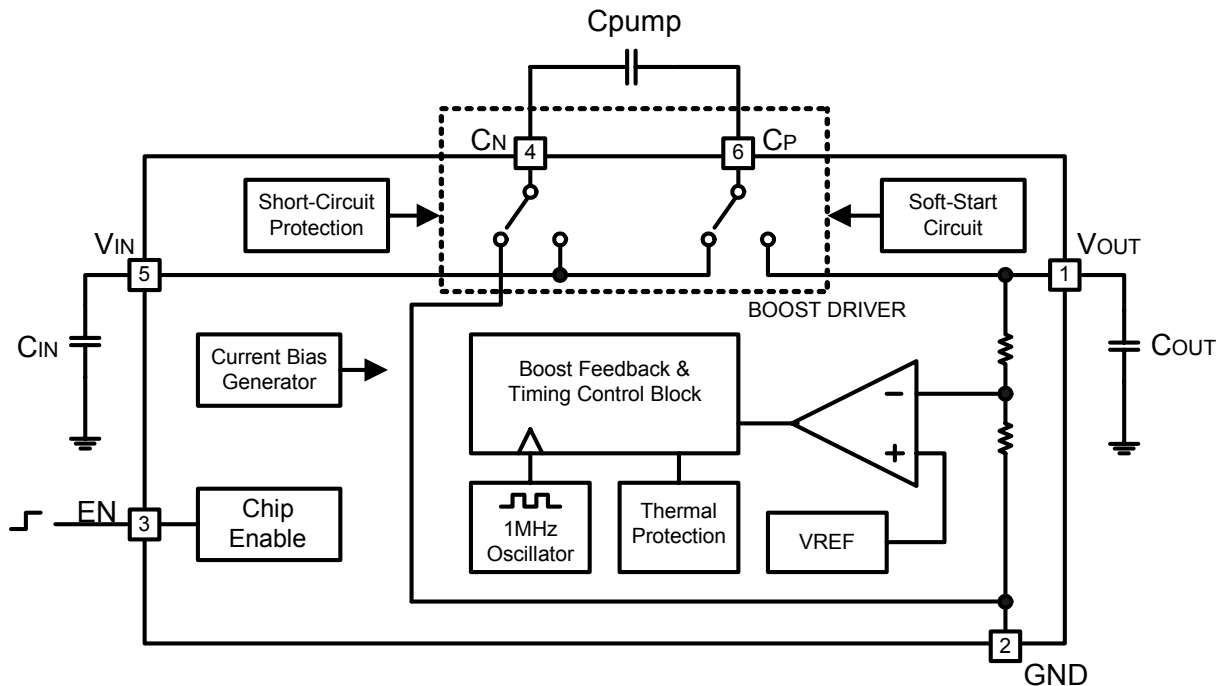

Figure 9. Block Diagram

Functional Description

The YB1300 regulated charge pump provides a regulated 5V output voltage for input voltages between 2.7V and 5V. This is accomplished by a step-up or boost mode of operation. A conversion clock of 50% duty cycle is generated. During the first half cycle, the pumping capacitor C_{PUMP} charges to V_{IN} . During the second half cycle, the voltage on C_{PUMP} is added to V_{IN} , then deliver to V_{OUT} . The output voltage is regulated by skipping clock cycles as necessary.

Soft-Start and Short-Circuit Protection Circuitry

The YB1300 includes soft-start circuitry to

limit inrush current at turn-on. When starting up, the output capacitor is charged through the charge-pump capacitor with a limited current source. When the output voltage approached to its design value, the soft-start is terminated and normal operation begins. If an overload condition occurs, for example, the output is shorted to ground, the output current is limited by the YB1300 switching technique.

Thermal Protection

The regulator has thermal shutdown circuitry that protects it from damage caused by high temperature conditions. The thermal protection circuitry shut down

the device when the junction temperature reached approximately 160 °C, allowing the device to cool. When the junction temperature cools to approximately 140 °C, the device is automatically reenabled. Continuously running the regulator into thermal shutdown can degrade reliability.

Shutdown Mode

A control pin on the regulator can be used to place the device into an energy-saving shutdown mode. In this mode, the output is disconnected from the input.

Layout Consideration

Due to large transient currents and high switching frequency produced by the YB1300, careful consideration of PCB layout is necessary. In order to minimize both input and output ripple, keep the capacitors as close as possible to the regulator using short, direct circuit traces. A ground plane and short connections to all capacitors will improve performance and

ensure proper regulation under all conditions. Figure 10 and Figure 11 show the recommended layout configuration.

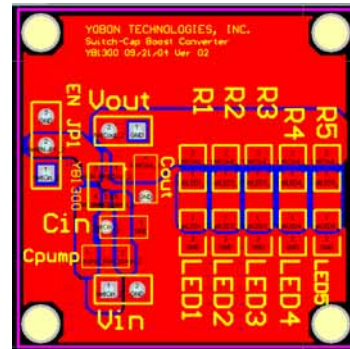

Figure 10. Top layer

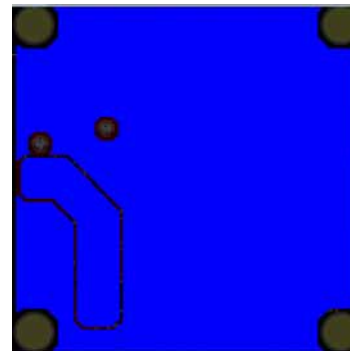
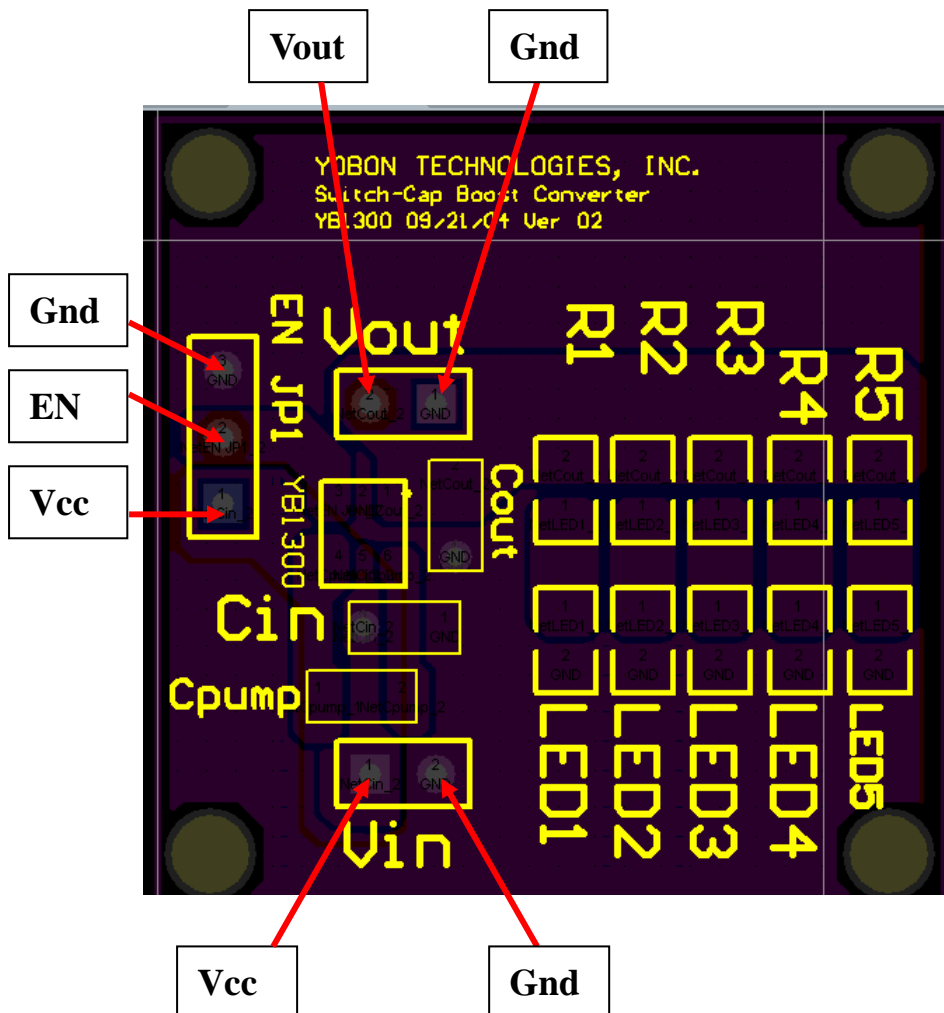
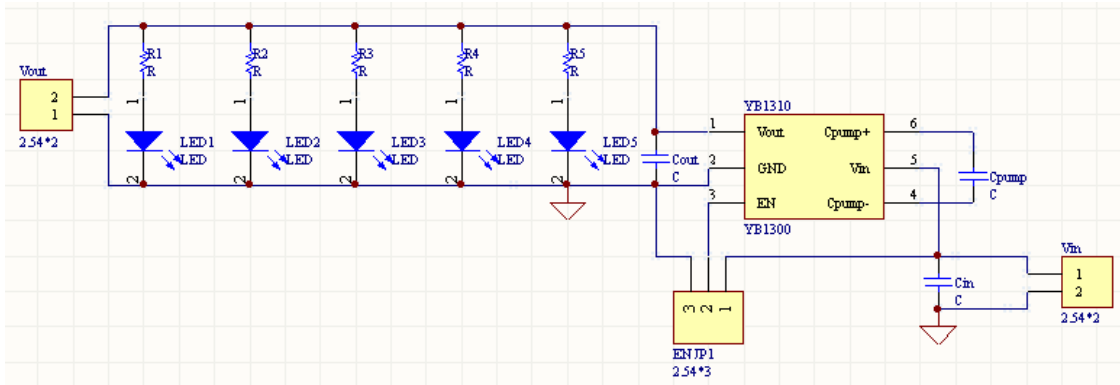
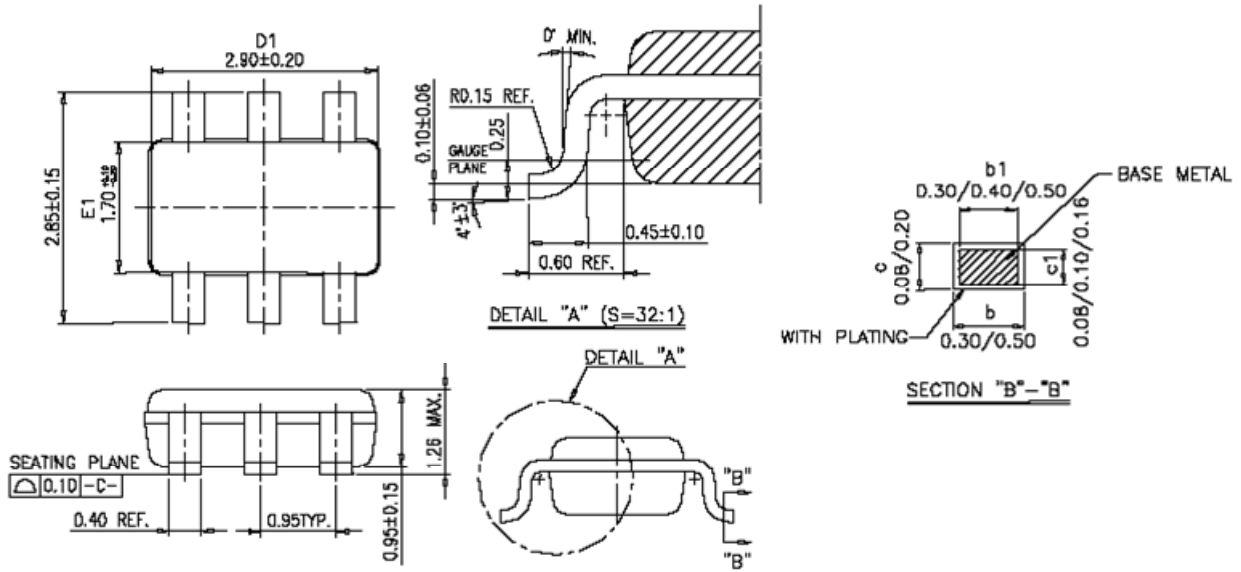

Figure 11. Bottom layer

Application Information



Package Information



Notes:

1. Dimension D1 & E1 does not include mold protrusion.
2. Coplanarity of all lead shall be (Before test) 0.1 MAX. from the seating plane. Unless otherwise specified.
3. general physical outline spec is refer to TMC's final visual inspection spec unless otherwise specified.