

# 50 AMP OVERVOLTAGE TRANSIENT SUPPRESSORS

## FEATURES

- PROPRIETARY *SOFT GLASS*<sup>®</sup> JUNCTION PASSIVATION FOR SUPERIOR RELIABILITY AND PERFORMANCE
- VOID FREE VACUUM DIE SOLDERING FOR MAXIMUM MECHANICAL STRENGTH AND HEAT DISSIPATION
- INDUSTRY'S LARGEST DIE FOR HIGHEST POWER CAPABILITY
- Very low forward voltage drop
- Increased capacity by parallel operation
- Protects expensive automotive electronics and mobile equipment

## MECHANICAL SPECIFICATION

*Die Size:*  
 0.216" Flat to Flat  
 Hex

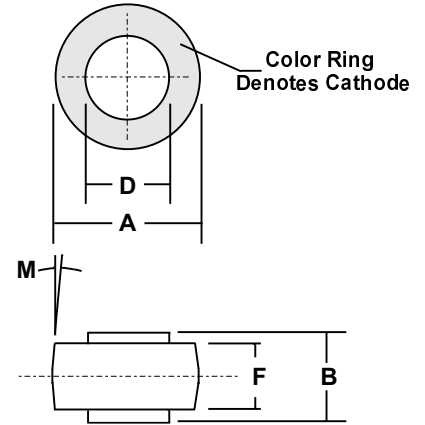

## MECHANICAL DATA

- Case: Molded Epoxy (UL Flammability Rating 94V-0)
- Finish: All external surfaces are silver plated for corrosion resistance superior solderability
- Soldering Temperature: 250 °C maximum
- Mounting Position: Any
- Polarity: Color band denotes cathode
- Weight: 0.6 Ounces (1.8 Grams)

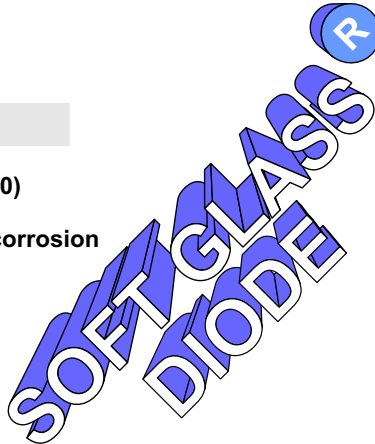

DIM	MILLIMETERS		INCHES	
	MIN	MAX	MIN	MAX
A	8.43	8.69	0.332	0.342
B	5.94	6.25	0.234	0.246
D	5.46	5.71	0.215	0.225
F	4.19	4.45	0.165	0.175
M	5° NOM		5° NOM	

## MAXIMUM RATINGS & ELECTRICAL CHARACTERISTICS

Ratings at 25 °C ambient temperature unless otherwise specified.  
 Single phase, half wave, 60 Hz resistive or inductive load.

PARAMETER (TEST CONDITIONS)	SYMBOL	RATINGS	UNITS
<b>Series Number</b>		<b>TVS5027S</b>	
Maximum Recurrent Peak Reverse Voltage	V <sub>RRM</sub>	23	VOLTS
Working Peak Reverse Voltage	V <sub>RWM</sub>		
Maximum DC Blocking Voltage	V <sub>DC</sub>		
Breakdown Voltage (I <sub>R</sub> = 100 mA dc, T <sub>c</sub> = 25 °C)	V <sub>(BR)</sub>	24 Min / 32 Max	
Average Forward Rectified Current	I <sub>o</sub>	50	AMPS
Non-repetitive Peak Forward Surge Current (Half wave, single phase, 60 Hz sine applied to rated load)	I <sub>FSM</sub>	800	
Repetitive Peak Reverse Surge Current (Time Constant = 10 mSec Duty Cycle ≤ 1.0%, T <sub>c</sub> = 25 °C)	I <sub>RSM</sub>	140	
Instantaneous Forward Voltage (I <sub>F</sub> = 100A@ 300 μSecpulse, T <sub>c</sub> = 25°C)	V <sub>F</sub>	1.05	VOLTS
Maximum Typical		1.00	
Maximum DC Reverse Current (V <sub>R</sub> = 20V DC, T <sub>c</sub> = 25 °C)	I <sub>R</sub>	200	nA
Maximum Thermal Resistance, Junction to Case (Note 1)	R <sub>θJC</sub>	0.8	°C/W
Junction Operating & Storage Temperature Range	T <sub>J</sub> , T <sub>STG</sub>	-65 to +175	°C

Notes: 1) Single Side Cooled

1.99729-0000