



**ELECTROSTATIC SENSITIVE DEVICE**  
OBSERVE HANDLING PRECAUTIONS

MITSUBISHI RF POWER MOS FET

# RD30HUF1

RoHS Compliance, Silicon MOSFET Power Transistor, 520MHz, 30W

## DESCRIPTION

RD30HUF1 is a MOS FET type transistor specifically designed for UHF RF power amplifiers applications.

## FEATURES

High power gain:  
Pout>30W, Gp>10dB @Vdd=12.5V, f=520MHz  
High Efficiency: 55%typ.

## APPLICATION

For output stage of high power amplifiers in UHF band mobile radio sets.

## RoHS COMPLIANT

RD30HUF1-101 is a RoHS compliant products.  
RoHS compliance is indicate by the letter "G" after the Lot Marking.

## OUTLINE DRAWING

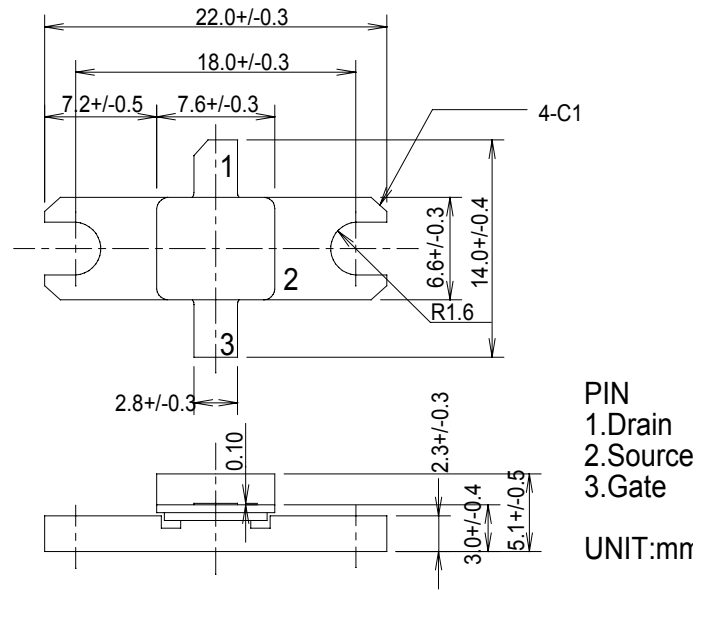

## ABSOLUTE MAXIMUM RATINGS

(Tc=25°C UNLESS OTHERWISE NOTED)

SYMBOL	PARAMETER	CONDITIONS	RATINGS	UNIT
Vdss	Drain to source voltage	Vgs=0V	30	V
Vgss	Gate to source voltage	Vds=0V	+/-20	V
Pch	Channel dissipation	Tc=25°C	75	W
Pin	Input power	Zg=Zl=50Ω	7.5	W
ID	Drain current	-	7	A
Tch	Channel temperature	-	175	°C
Tstg	Storage temperature	-	-40 to +175	°C
Rth j-c	Thermal resistance	junction to case	2.0	°C/W

Note 1: Above parameters are guaranteed independently.

## ELECTRICAL CHARACTERISTICS (Tc=25°C, UNLESS OTHERWISE NOTED)

SYMBOL	PARAMETER	CONDITIONS	LIMITS			UNIT
			MIN	TYP	MAX.	
Idss	Zero gate voltage drain current	VDS=17V, VGS=0V	-	-	200	uA
Igss	Gate to source leak current	VGS=10V, VDS=0V	-	-	1	uA
VTH	Gate threshold voltage	VDS=12V, Ids=1mA	1.2	1.7	2.2	V
Pout	Output power	f=520MHz, VDD=12.5V	30	35	-	W
ηD1	Drain efficiency	Pin=3W, Idq=1.0A	50	55	-	%
	Load VSWR tolerance	VDD=15.2V, Po=30W(PinControl) f=520MHz, Idq=1.0A, Zg=50Ω Load VSWR=20:1(All Phase)	No destroy			-

Note : Above parameters , ratings , limits and conditions are subject to change.



ELECTROSTATIC SENSITIVE DEVICE  
OBSERVE HANDLING PRECAUTIONS

MITSUBISHI RF POWER MOS FET

# RD30HUF1

RoHS Compliance,

Silicon MOSFET Power Transistor, 520MHz, 30W

## TYPICAL CHARACTERISTICS

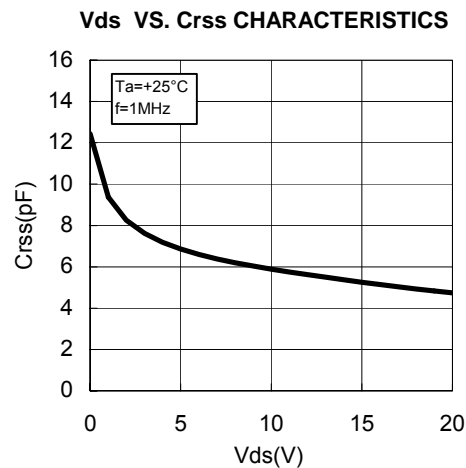
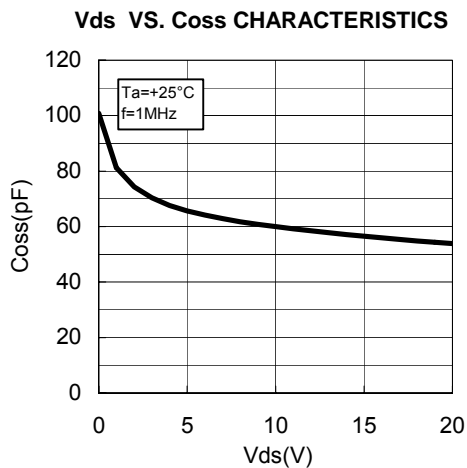
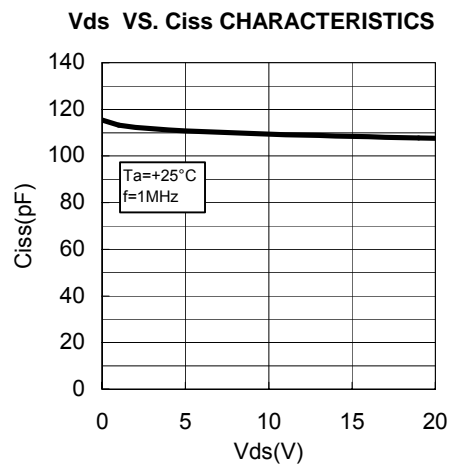
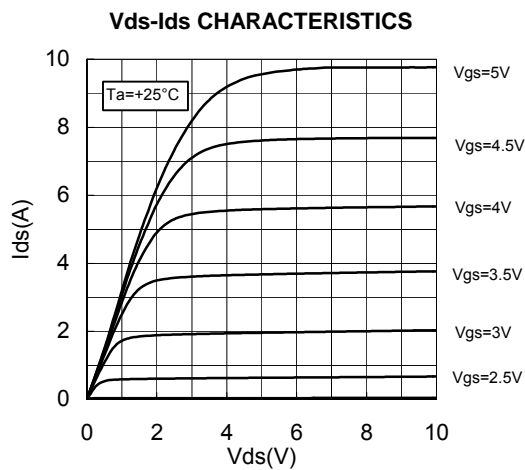
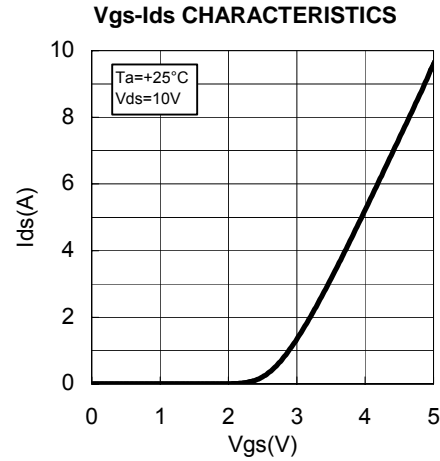
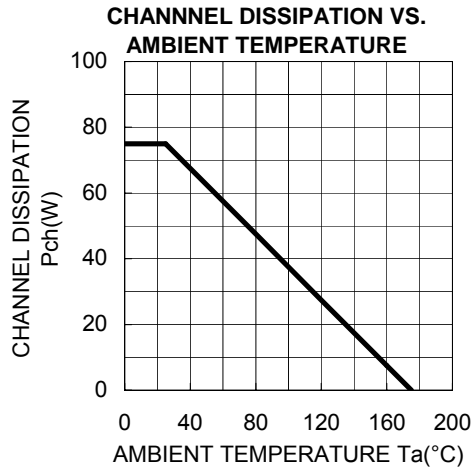



**ELECTROSTATIC SENSITIVE DEVICE**  
OBSERVE HANDLING PRECAUTIONS

MITSUBISHI RF POWER MOS FET

**RD30HUF1**

RoHS Compliance,

Silicon MOSFET Power Transistor, 520MHz, 30W

**TYPICAL CHARACTERISTICS**

**Pin-Po CHARACTERISTICS**

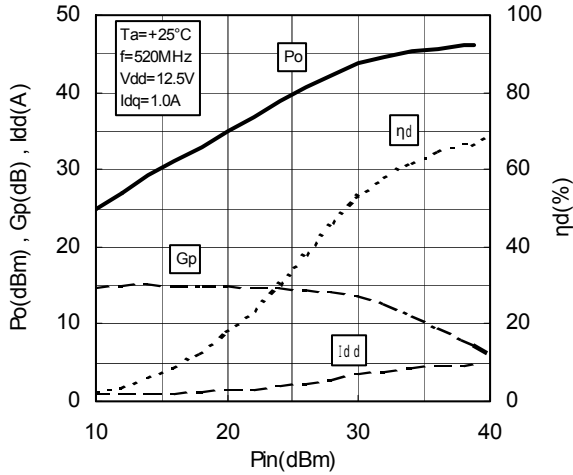

**Pin-Po CHARACTERISTICS**

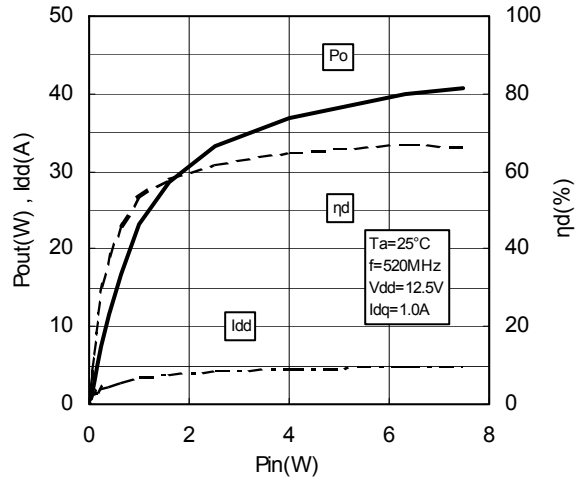

**Vdd-Po CHARACTERISTICS**

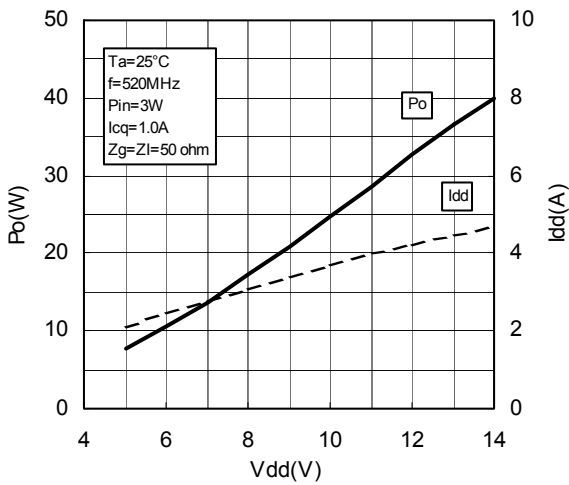

**Vgs-Ids CHARACTERISTICS 2**

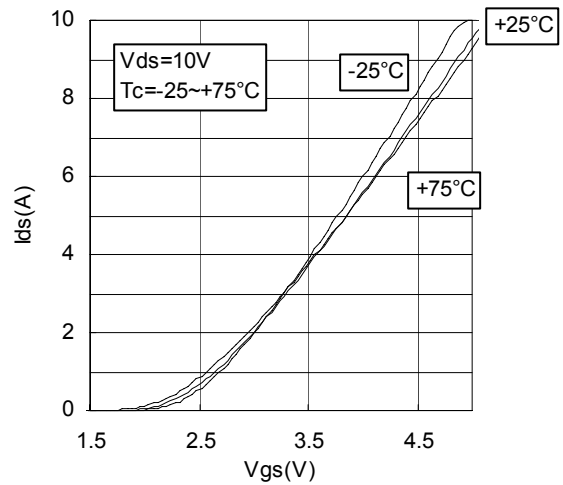

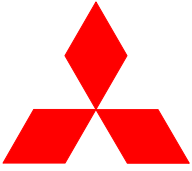

ELECTROSTATIC SENSITIVE DEVICE  
OBSERVE HANDLING PRECAUTIONS

MITSUBISHI RF POWER MOS FET

# RD30HUF1

RoHS Compliance, Silicon MOSFET Power Transistor, 520MHz, 30W

## TEST CIRCUIT (f=520MHz)

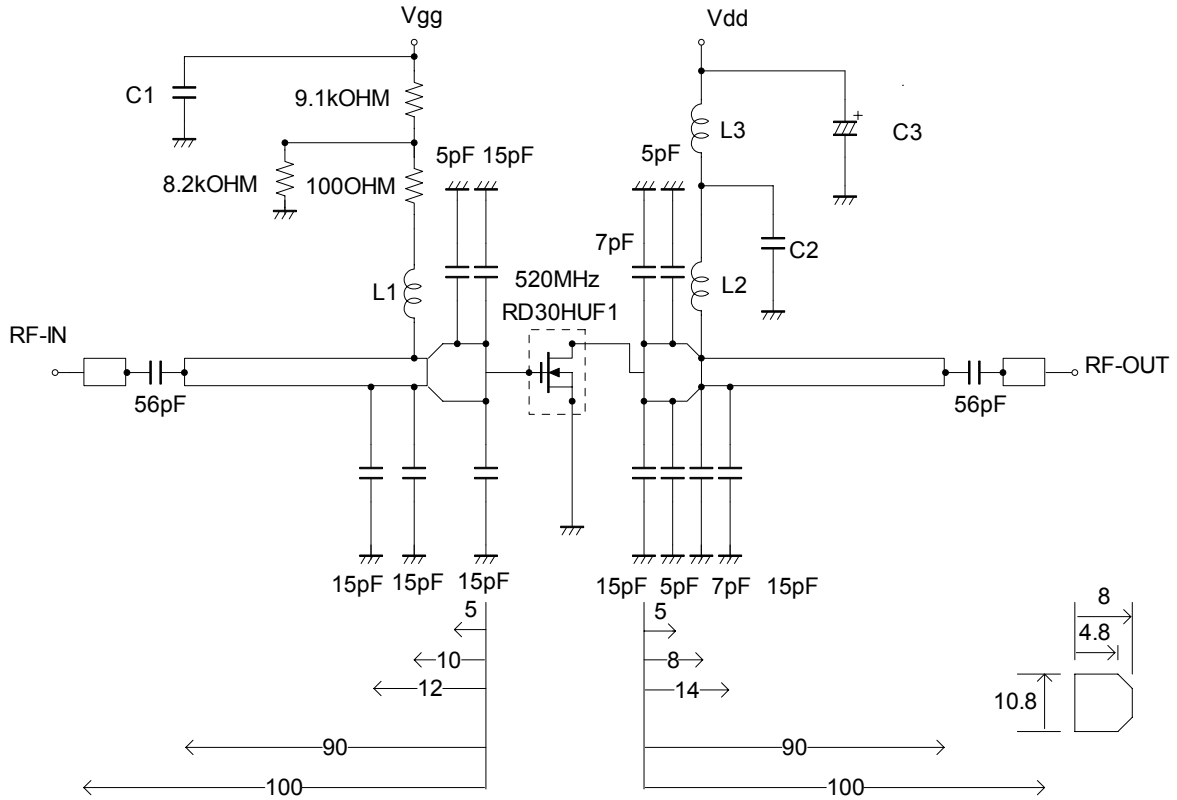

C1: 2200pF 10uF in parallel

C2: 2200pF\*2 in parallel

C3: 2200pF, 330uF in parallel

L1: 3Turns, l.D6mm, D1.6mm P=1 silver plated copper wire

L2: 2Turns, l.D6mm, D1.6mm P=1 silver plated copper wire

L3: 4Turns, l.D6mm, D1.6mm P=1 silver plated copper wire

Note: Board material-Teflon substrate

micro strip line width=4.2mm/50OHM, er:2.7, t=1.6mm

Dimensions:mm

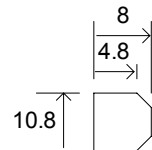



ELECTROSTATIC SENSITIVE DEVICE  
OBSERVE HANDLING PRECAUTIONS

MITSUBISHI RF POWER MOS FET

**RD30HUF1**

RoHS Compliance, Silicon MOSFET Power Transistor, 520MHz, 30W

**INPUT/OUTPUT IMPEDANCE VS.FREQUENCY CHARACTERISTICS**

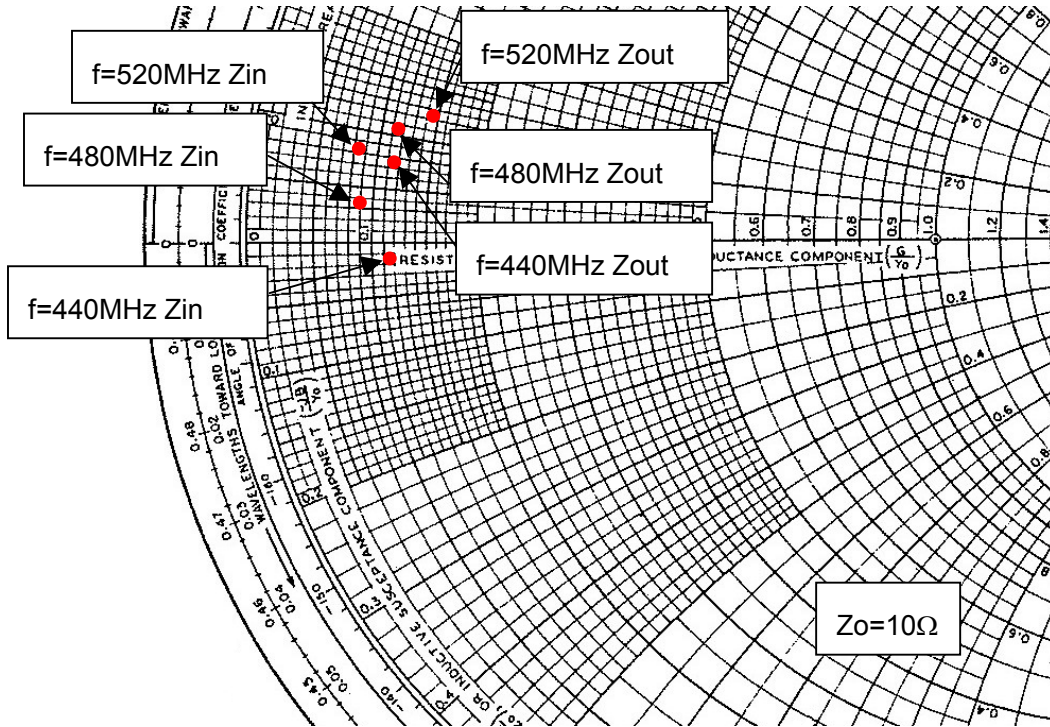

Z<sub>in</sub> , Z<sub>out</sub>

F (MHz)	Z <sub>in</sub> (ohm)	Z <sub>out</sub> (ohm)	Conditions
440	1.16-j0.14	1.17+j0.74	
480	0.90+j0.35	1.15+j1.07	P <sub>o</sub> =38W, V <sub>dd</sub> =12.5V, P <sub>in</sub> =3.0W
520	0.88+j0.84	1.47+j1.24	P <sub>o</sub> =35W, V <sub>dd</sub> =12.5V, P <sub>in</sub> =3.0W



**ELECTROSTATIC SENSITIVE DEVICE**  
OBSERVE HANDLING PRECAUTIONS

MITSUBISHI RF POWER MOS FET

# RD30HUF1

RoHS Compliance, Silicon MOSFET Power Transistor, 520MHz, 30W

RD30HUF1 S-PARAMETER DATA (@V<sub>dd</sub>=12.5V, I<sub>d</sub>=500mA)

Freq. [MHz]	S11		S21		S12		S22	
	(mag)	(ang)	(mag)	(ang)	(mag)	(ang)	(mag)	(ang)
100	0.870	-173.4	7.566	74.2	0.016	-8.8	0.723	-170.2
150	0.880	-177.3	4.825	63.2	0.015	-18.0	0.748	-172.5
200	0.890	-179.5	3.398	55.1	0.013	-23.7	0.778	-173.9
250	0.902	178.2	2.568	47.0	0.011	-27.9	0.817	-175.6
300	0.911	176.0	1.982	40.2	0.010	-31.1	0.832	-177.6
350	0.921	174.1	1.588	34.5	0.008	-31.3	0.857	-179.7
400	0.930	172.1	1.299	29.0	0.007	-29.2	0.879	178.3
450	0.931	170.0	1.070	23.9	0.005	-21.8	0.887	176.3
500	0.941	168.0	0.907	20.3	0.004	-9.5	0.901	174.2
520	0.946	167.1	0.852	18.7	0.004	-3.9	0.908	173.4
550	0.946	166.3	0.780	15.9	0.004	7.5	0.913	172.3
600	0.947	164.2	0.673	12.5	0.004	28.3	0.916	170.5
650	0.951	162.5	0.589	10.1	0.004	46.8	0.928	168.6
700	0.957	160.7	0.522	6.6	0.006	53.0	0.932	166.7
750	0.960	159.1	0.464	4.1	0.007	56.5	0.936	164.9
800	0.962	157.6	0.419	2.2	0.007	63.6	0.942	163.1
850	0.962	155.8	0.383	-1.2	0.009	64.1	0.945	161.6
900	0.962	154.2	0.341	-3.0	0.009	63.5	0.946	160.0
950	0.961	152.7	0.318	-4.2	0.010	65.6	0.952	158.2
1000	0.961	151.2	0.296	-7.4	0.012	65.3	0.955	157.0
1050	0.965	149.6	0.270	-8.3	0.012	64.6	0.955	155.4
1100	0.964	148.2	0.259	-9.4	0.014	64.8	0.957	153.6

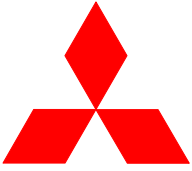

**ELECTROSTATIC SENSITIVE DEVICE**  
OBSERVE HANDLING PRECAUTIONS

**MITSUBISHI RF POWER MOS FET**

**RD30HUF1**

**RoHS Compliance, Silicon MOSFET Power Transistor, 520MHz, 30W**

---

— Keep safety first in your circuit designs! —

Mitsubishi Electric Corporation puts the maximum effort into making semiconductor products better and more reliable, but there is always the possibility that trouble may occur with them. Trouble with semiconductors may lead to personal injury, fire or property damage. Remember to give due consideration to safety when making your circuit designs, with appropriate measures such as (i) placement of substitutive, auxiliary circuits, (ii) use of non-flammable material or (iii) prevention against any malfunction or mishap.