



1A Low Dropout Positive Adjustable or Fixed-Mode Regulator

■ FEATURES

- 1.4V maximum dropout at full load current
- Fast transient response
- Output current limiting
- Built-in thermal shutdown
- Needs Only 1uF Capacitor for stability
- Good noise rejection
- 3-Terminal Adjustable or Fixed 1.5V, 1.8V, 1.9V, 2.5V, 3.3V, 5.0V
- Low ESR Ceramic Capacitor for output stability
- Packages: SOT-223, TO-252, SOT-89, -RoHS Compliant

■ APPLICATIONS

- PC peripheral
- Communication
- LCD Modules

■ ORDERING INFORMATION

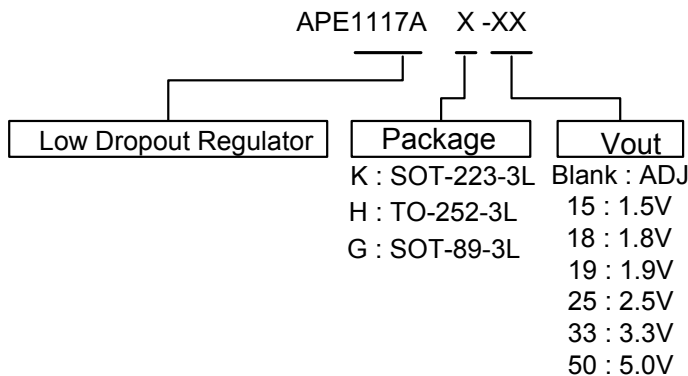

■ GENERAL DESCRIPTION

APE1117A is a low dropout positive adjustable or fixed-mode regulator with minimum of 1A output current capability. The regulator is able to operate with output Capacitors as small as 1uF Ceramic Capacitor for stability. The product is specifically designed to provide well-regulated supply for low voltage IC applications such as high-speed bus termination and low current 3.3V logic supply. APE1117A is also well suited for other applications such as VGA cards. APE1117A is guaranteed to have lower than 1.4V dropout at full load current making it ideal to provide well-regulated outputs of 1.25 to 5.0 with 6.4V to 12V input supply.

■ TYPICAL CIRCUIT

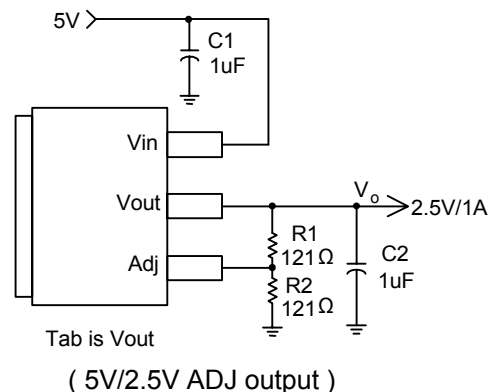
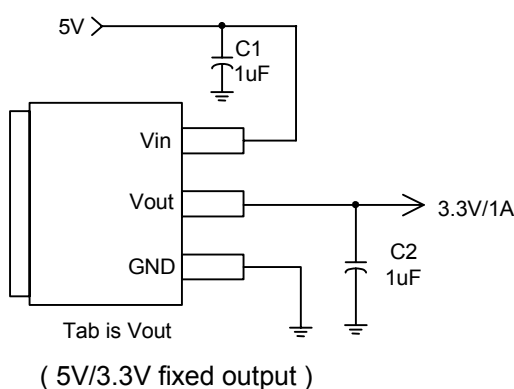

Note: $V_o = V_{REF} * (1 + \frac{R_2}{R_1})$



■ CONNECTION DIAGRAM

3 PIN SOT-223

(Top View)

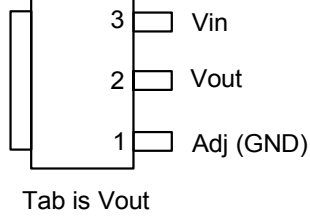

3 PIN TO-252

(Top View)

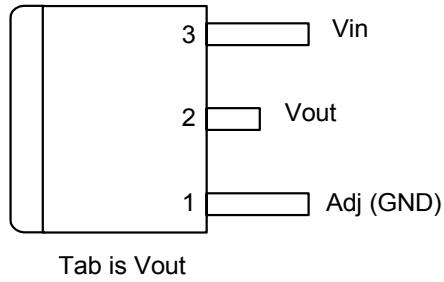

3 PIN SOT-89

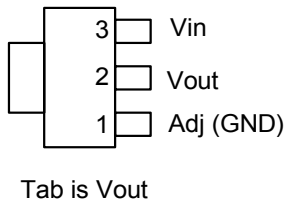

■ BLOCK DIAGRAM

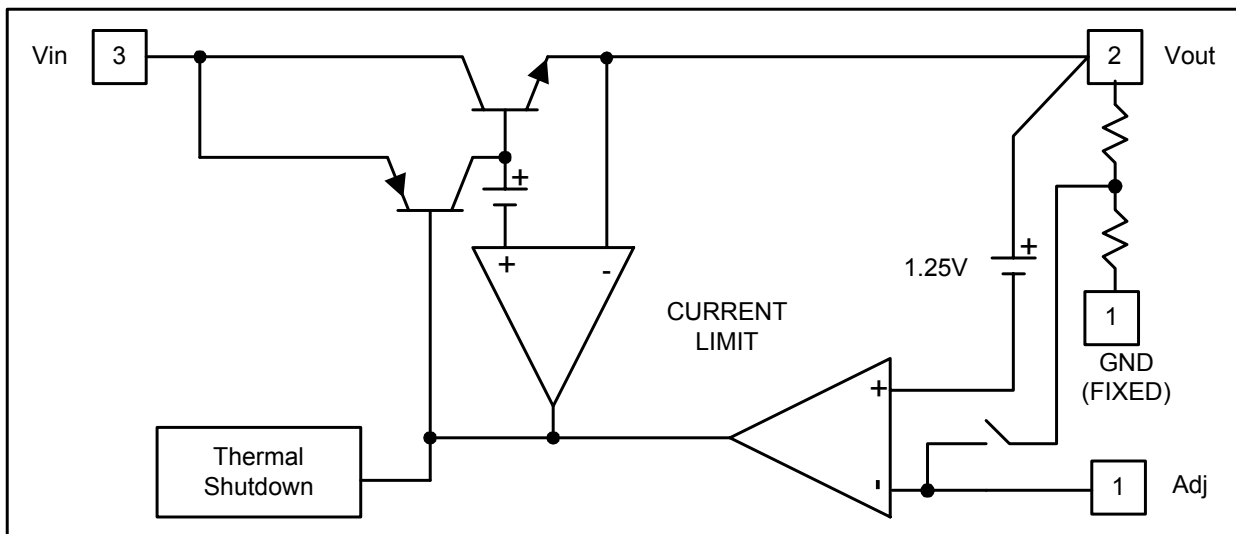



■ PIN DESCRIPTIONS

NAME	I/O	PIN #	FUNCTION
Adj (GND)	I	1	A resistor divider from this pin to the Vout pin and ground sets the output voltage. (Ground only for Fixed-Mode)
Vout	O	2	The output of the regulator. A minimum of 1uF capacitor must be connected from this pin to ground to insure stability.
Vin	I	3	The input pin of regulator. A minimum of 1uF capacitor is connected from this pin to ground to insure that the input voltage does not sag below the minimum dropout voltage during the load transient response. This pin must always be 1.4V higher than Vout in order for the device to regulate properly.

■ ABSOLUTE MAXIMUM RATINGS

Symbol	Parameter	Rating	Unit
Vin	DC Supply Voltage	-0.3 to 16	V
<u>P_D</u>	Power Dissipation SOT-223 SOT-89 TO-252	850 330 1050	mW
<u>T_{ST}</u>	Storage Temperature	-65 to +150	°C
T _{OP}	Operating Junction Temperature Range	0 to +150	°C



■ ELECTRICAL CHARACTERISTICS (Under Operating Conditions)

PARAMETER	CONDITIONS		MIN	TYP	MAX	UNIT
Reference Voltage	APE1117A-ADJ	$T_J=25^{\circ}\text{C}, (V_{IN-OUT})=1.5\text{V}$ $I_O=10\text{mA}$	1.225	1.250	1.275	V
Output Voltage	APE1117A-1.5	$I_{OUT} = 10\text{mA}, T_J = 25^{\circ}\text{C},$ $3\text{V } V_{IN} \ 12\text{V}$	1.470	1.500	1.530	V
	APE1117A-1.8	$I_{OUT} = 10\text{mA}, T_J = 25^{\circ}\text{C},$ $3.3\text{V } V_{IN} \ 12\text{V}$	1.764	1.800	1.836	V
	APE1117A-1.9	$I_{OUT} = 10\text{mA}, T_J = 25^{\circ}\text{C},$ $3.3\text{V } V_{IN} \ 12\text{V}$	1.862	1.900	1.938	V
	APE1117A-2.5	$I_{OUT} = 10\text{mA}, T_J = 25^{\circ}\text{C},$ $4\text{V } V_{IN} \ 12\text{V}$	2.450	2.500	2.550	V
	APE1117A-3.3	$I_{OUT} = 10\text{mA}, T_J = 25^{\circ}\text{C},$ $4.8\text{V } V_{IN} \ 12\text{V}$	3.235	3.300	3.365	V
	APE1117A-5.0	$I_{OUT} = 10\text{mA}, T_J = 25^{\circ}\text{C},$ $6.5\text{V } V_{IN} \ 12\text{V}$	4.900	5.000	5.100	V
Line Regulation	APE1117A-XXX	$I_O=10\text{mA}, V_{OUT}+1.5\text{V}<V_{IN}<V_{out}+6\text{V},$ $T_J=25^{\circ}\text{C}$			0.5	%
Load Regulation	APE1117A-ADJ	$V_{IN}=3.3\text{V}, V_{adj}=0, 0\text{mA}<I_O<1\text{A},$ $T_J=25^{\circ}\text{C}$ (Note 1,2)			1	%
	APE1117A-1.5	$V_{IN}=3\text{V}, 0\text{mA}<I_O<1\text{A},$ $T_J=25^{\circ}\text{C}$ (Note 1,2)		12	15	mV
	APE1117A-1.8	$V_{IN}=3.3\text{V}, 0\text{mA}<I_O<1\text{A},$ $T_J=25^{\circ}\text{C}$ (Note 1,2)		15	18	mV
	APE1117A-1.9	$V_{IN}=3.3\text{V}, 0\text{mA}<I_O<1\text{A},$ $T_J=25^{\circ}\text{C}$ (Note 1,2)		16	19	mV
	APE1117A-2.5	$V_{IN}=4\text{V}, 0\text{mA}<I_O<1\text{A},$ $T_J=25^{\circ}\text{C}$ (Note 1,2)		20	25	mV
	APE1117A-3.3	$V_{IN} = 5\text{V}, 0 \ I_{OUT} \ 1\text{A},$ $T_J=25^{\circ}\text{C}$ (Note 1,2)		26	33	mV
	APE1117A-5.0	$V_{IN} = 8\text{V}, 0 \ I_{OUT} \ 1\text{A},$ $T_J=25^{\circ}\text{C}$ (Note 1,2)		40	50	mV
Dropout Voltage ($V_{IN}-V_{OUT}$)	APE1117A-ADJ/1.5/1.8 /1.9/2.5/3.3/5.0	$I_{OUT} = 1\text{A}, \Delta V_{OUT}=1\%V_{OUT}$		1.3	1.5	V
Current Limit	APE1117A-ADJ/1.5/1.8 /1.9/2.5/3.3/5.0	$(V_{IN}-V_{OUT}) = 5\text{V}$	1.1			A
Minimum Load Current	APE1117A-XXX	$0^{\circ}\text{C} \ T_J \ 125^{\circ}\text{C}$		1	3	mA
Thermal Regulation	$T_A=25^{\circ}\text{C}, 30\text{ms pulse}$			0.008	0.04	%/W
Ripple Rejection	$F=120\text{Hz}, C_{OUT}=25\mu\text{F Tantalum}, I_{OUT}=1\text{A}$					
	APE1117A-XXX	$V_{IN}=V_{OUT}+3\text{V}$		60	70	dB
Temperature Stability	$I_O=10\text{mA}$			0.5		%
Thermal Shutdown Temperature				150		$^{\circ}\text{C}$
Thermal Shutdown Temperature Recovery				130		$^{\circ}\text{C}$
θ_{JA} Thermal Resistance Junction-to-Ambient(No heat sink ;No air flow)	SOT-89			300		$^{\circ}\text{C/W}$
	SOT-223			117		
	TO-252			92		
θ_{JC} Thermal Resistance Junction-to-Case	SOT-89 : Control Circuitry/Power Transistor			100		$^{\circ}\text{C/W}$
	SOT-223 : Control Circuitry/Power Transistor			15		
	TO-252 : Control Circuitry/Power Transistor			10		

Note1: See thermal regulation specifications for changes in output voltage due to heating effects. Line and load regulation are measured at a constant junction temperature by low duty cycle pulse testing. Load regulation is measured at the output lead = 1/18" from the package.

Note2: Line and load regulation are guaranteed up to the maximum power dissipation of 15W. Power dissipation is determined by the difference between input and output differential and the output current. Guaranteed maximum power dissipation will not be available over the full input/output range.

Note3: Quiescent current is defined as the minimum output current required in maintaining regulation. At 12V input/output differential the device is guaranteed to regulate if the output current is greater than 10mA.



■ TYPICAL PERFORMANCE CHARACTERISTICS

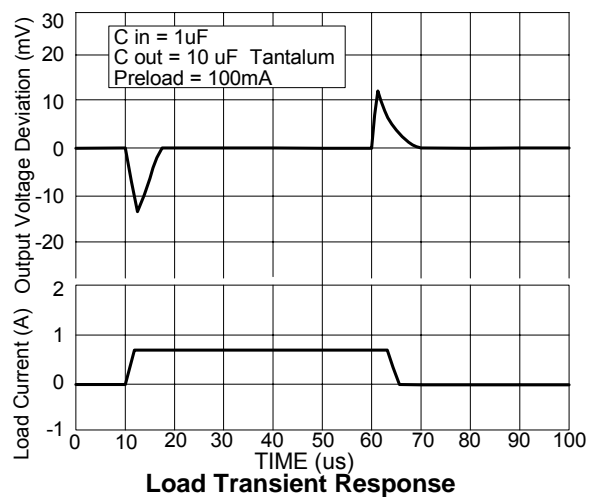
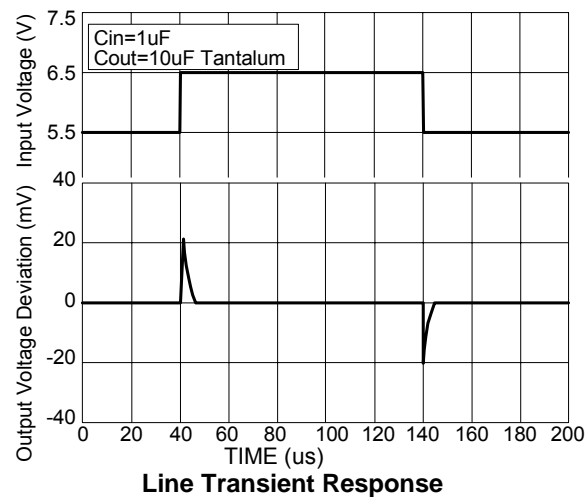
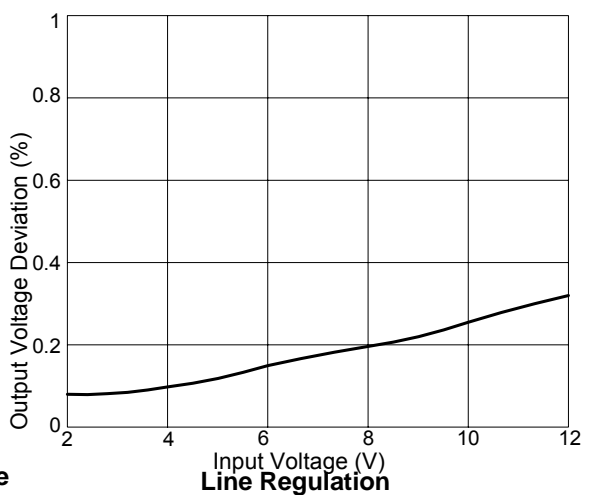
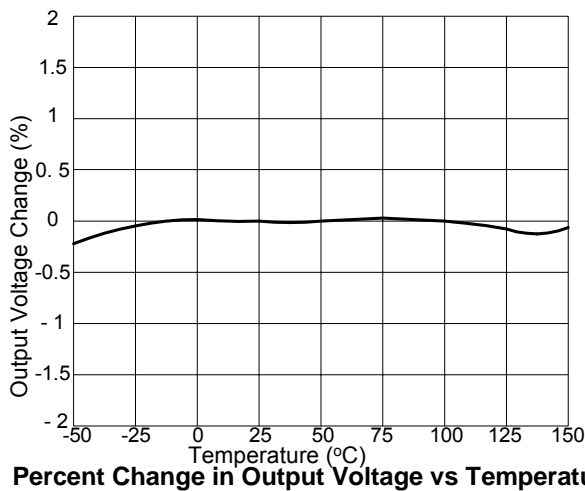
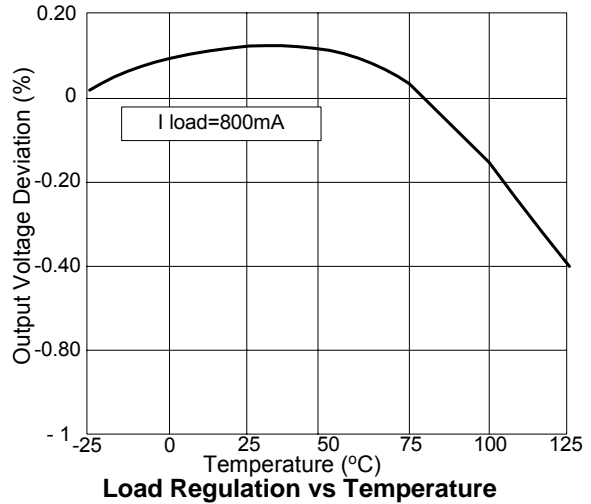
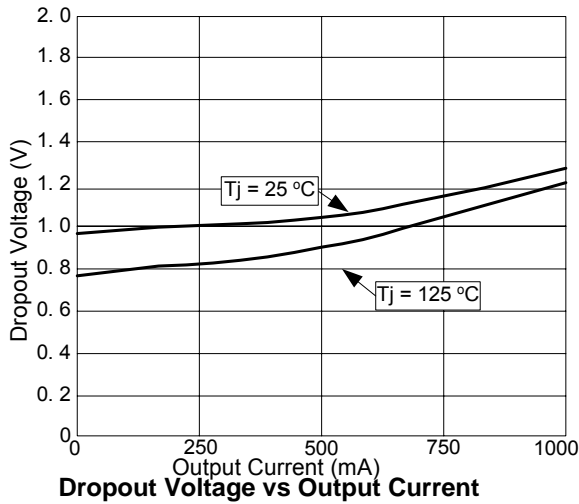



MARKING INFORMATION

(1) SOT-223-3L

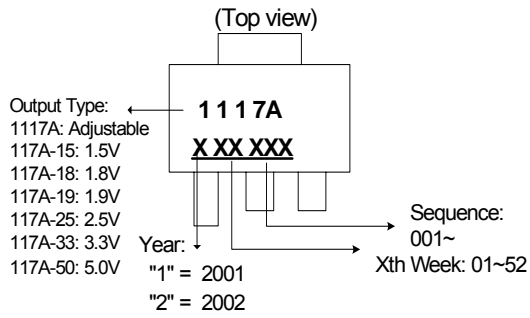

(2) TO-252-3L

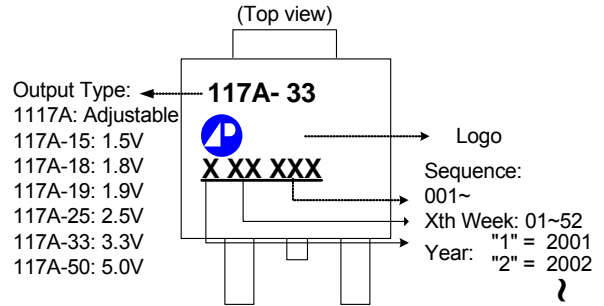

(3) SOT-89-3L

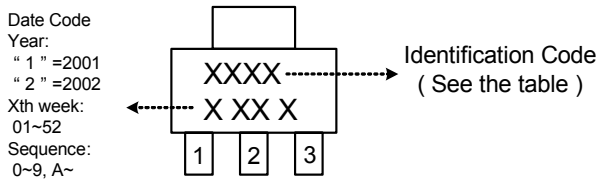

Identification code	Output version
17AA	APE1117A-ADJ
17AB	APE1117A-1.5V
17AC	APE1117A-1.8V
17AG	APE1117A-1.9V
17AD	APE1117A-2.5V
17AE	APE1117A-3.3V
17AF	APE1117A-5.0V



Package Outline : TO-252

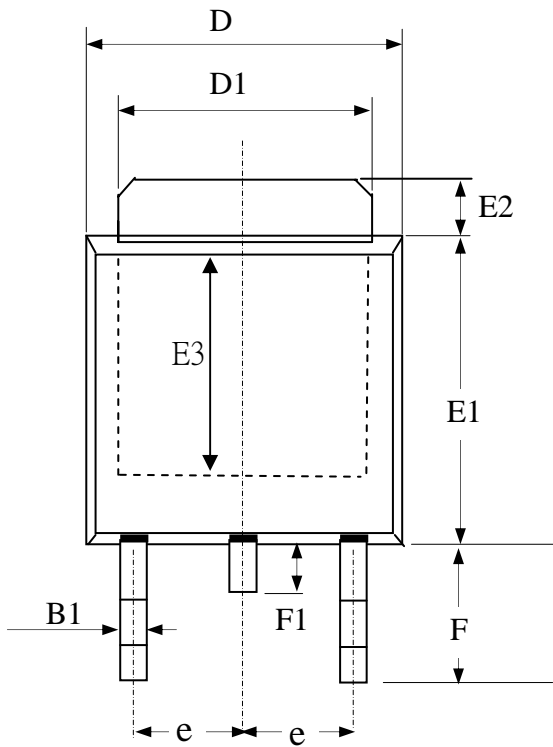

SYMBOLS	Millimeters		
	MIN	NOM	MAX
A2	1.80	2.30	2.80
A3	0.40	0.50	0.60
B1	0.40	0.70	1.00
D	6.00	6.50	7.00
D1	4.80	5.35	5.90
E3	3.50	4.00	4.50
F	2.20	2.63	3.05
F1	0.5	0.85	1.20
E1	5.10	5.70	6.30
E2	0.50	1.10	1.80
e	--	2.30	--
C	0.35	0.50	0.65

- 1.All Dimensions Are in Millimeters.
- 2.Dimension Does Not Include Mold Protrusions.

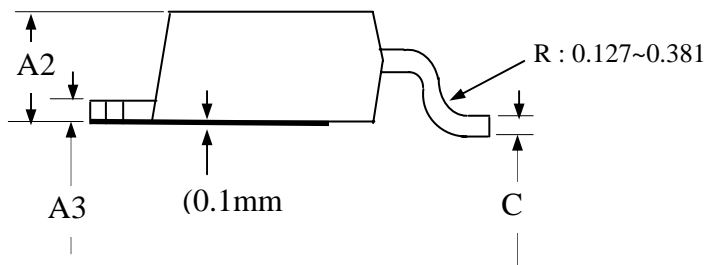

Part Marking Information & Packing : TO-252

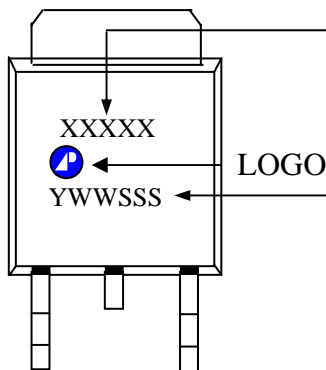

Part Number

ADJ : 1117A
 1.5V : 117A-15
 1.8V : 117A-18
 5.0V : 117A-50

Date Code (YWWSSS)

Y : Last Digit Of The Year
 WW : Week
 SSS : Sequence



Package Outline : SOT-223

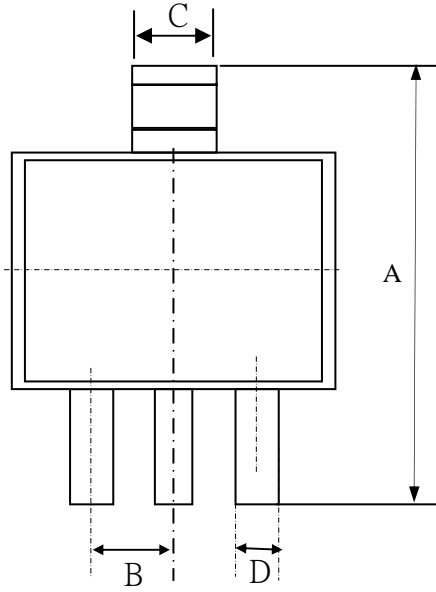

SYMBOLS	Millimeters		
	MIN	NOM	MAX
A	6.70	7.00	7.30
B	---	2.3	---
C	2.90	3.00	3.10
D	0.60	0.70	0.80
G	0.25	0.30	0.35
E	6.30	6.50	6.70
F	1.40	1.60	1.80
K	0.02	0.06	0.10

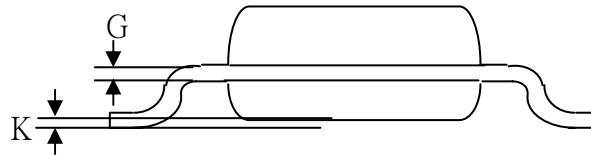
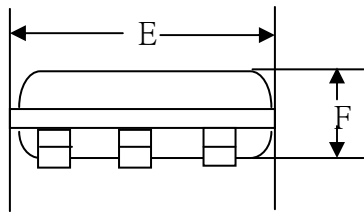

1. All Dimension Are In Millimeters.
2. Dimension Does Not Include Mold Protrusions.

Part Marking Information & Packing : SOT-223

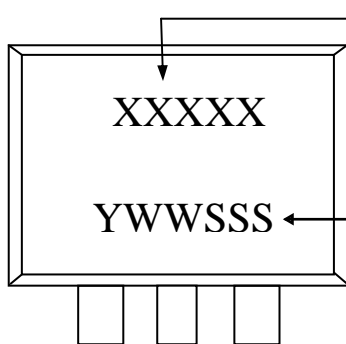

Part Number

ADJ : 1117A
 1.5V : 117A-15
 1.8V : 117A-18
 ↓
 5.0V : 117A-50

Date Code (YWWSSS)

Y : Last Digit Of The Year
 WW : Week
 SSS : Sequence



Package Outline & Packing : SOT-89

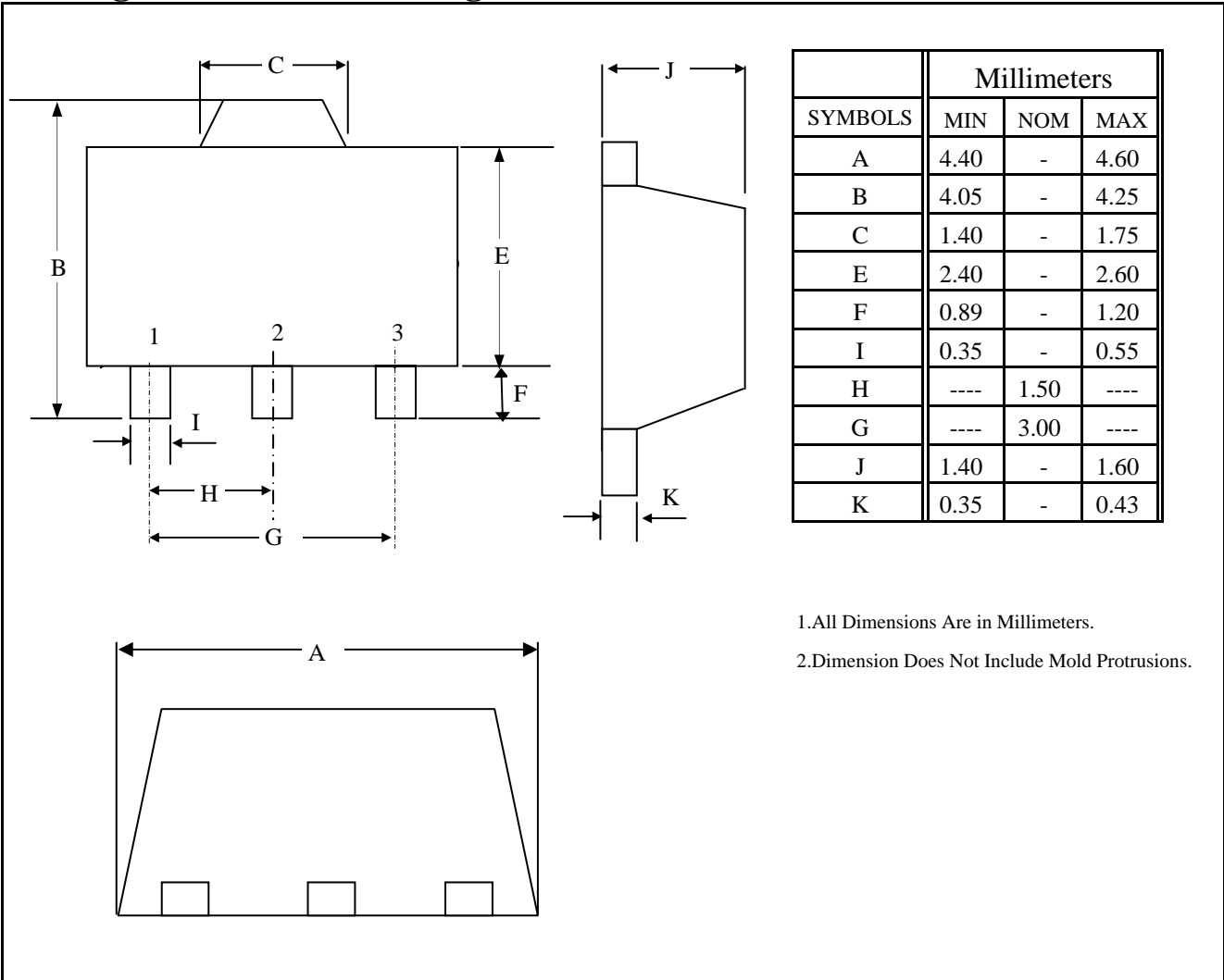

Part Marking Information : SOT-89

