

0603 Package 0.6mm Height Yellowish Green LED

Features

- Package in 8mm tape on 7" diameter reel
- Compatible with automatic placement equipment
- Compatible with infrared and vapor phase reflow solder process
- Mono-color type
- RoHS



QSLP1FF1

Descriptions

- The SMD series enable smaller board size, higher packing density, reduced storage space, and small equipment.
- Besides, light weight makes them ideal for miniature applications.

Applications

- Automotive: backlighting in dashboard and switch
- Telecommunication: indicator and backlighting in telephone and fax
- Flat backlight for LCD, switches and symbols
- General use

Device Selection Guide

Part No.	Chip		Lens Color
	Material	Emitted Color	
TSP1-FF1608H6-2630	AllnGaP	Yellowish Green	Water Clear

0603 Package 0.6mm Height Yellowish Green LED

TSP1-FF1608H6-2630

Absolute Maximum Ratings (Ta=25°C)

Parameter	Symbol	Rating	Unit
Reverse Voltage	VR	5	V
Forward Current	IF	25	mA
Operating Temperature	Topr	-40 ~ +85	°C
Storage Temperature	Tstg	-40 ~ +90	°C
Electrostatic Discharge	ESD	150	V
Power Dissipation	Pd	110	mW
Peak Forward Current (Duty 1/10 @1KHz)	IFP	100	mA
Soldering Temperature	Tsol	Reflow Soldering: 260°C for 10 sec.	
		Hand Soldering: 350 °C for 3 sec.	

0603 Package 0.6mm Height Yellowish Green LED

TSP1-FF1608H6-2630

Electro-Optical Characteristics (Ta=25°C)

Parameter	Symbol	Min.	Typ.	Max.	Unit	Condition
Luminous Intensity	I _v	35	-----	70.7	mcd	IF=20mA
Peak Wavelength	λ _p	-----	570	-----	nm	
Dominant Wavelength	λ _d	568.5	-----	574.5	nm	
Spectrum Radiation Bandwidth	Δλ	-----	20	-----	nm	
Viewing Angle	2θ _{1/2}	-----	120	-----	deg	
Forward Voltage	V _F	1.75	-----	2.35	V	
Reverse Current	I _R	-----	-----	10	μA	VR=5V

Notes: Tolerance of Luminous Intensity ±10%

Tolerance of Dominant wavelength ±1nm

Tolerance of Forward Voltage ±0.1V

0603 Package 0.6mm Height Yellowish Green LED

TSP1-FF1608H6-2630

Typical Electro-Optical Characteristics Curves (Ta=25°C)

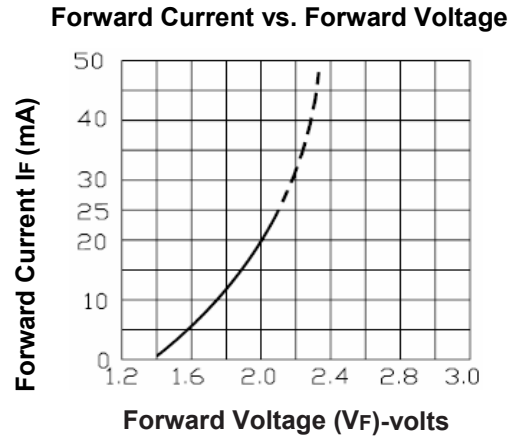
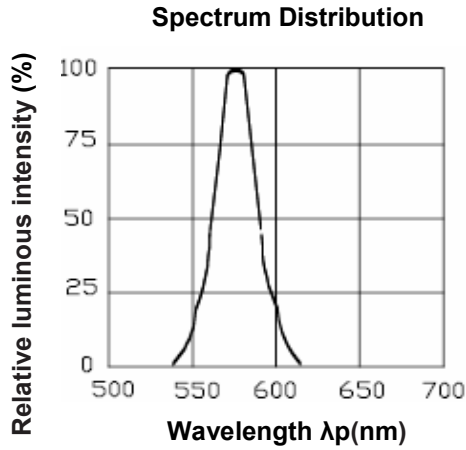

Luminous Intensity vs. Ambient Temperature

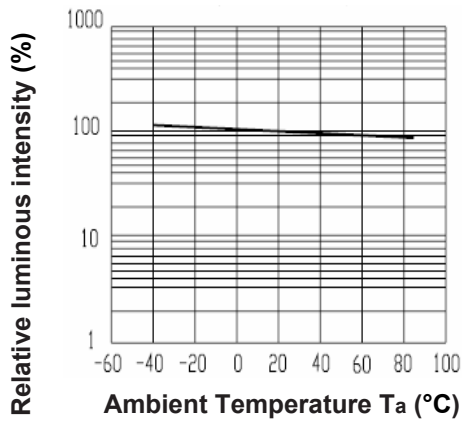

Luminous Intensity vs. Forward Current

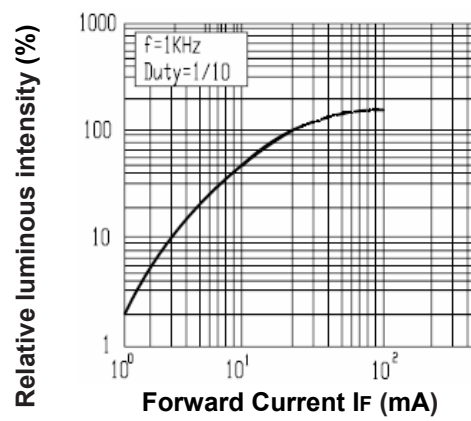

Forward Current Derating Curve

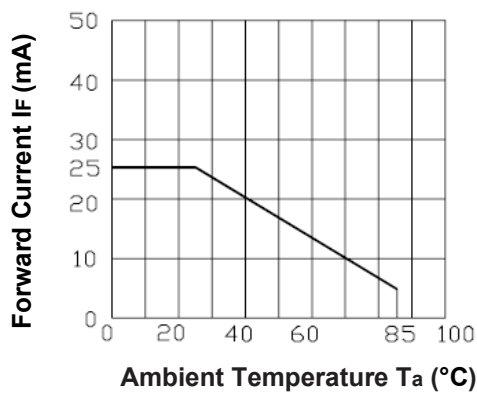

Radiation Diagram

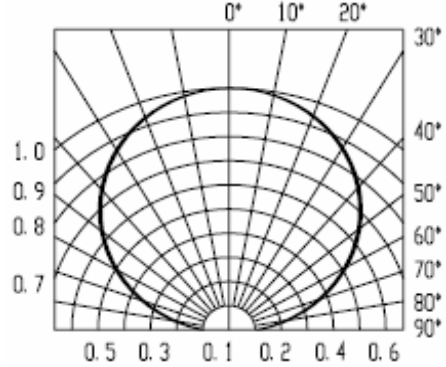

0603 Package 0.6mm Height Yellowish Green LED

TSP1-FF1608H6-2630

Package Outline Dimensions (Unit=mm)

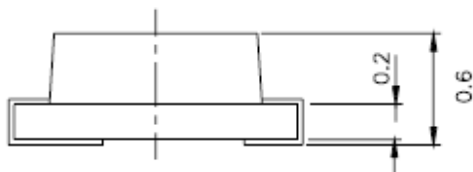
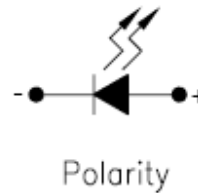
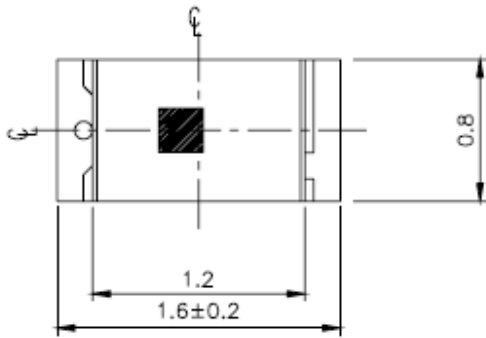

Note: The tolerances unless mentioned is ± 0.1 mm, Unit = mm

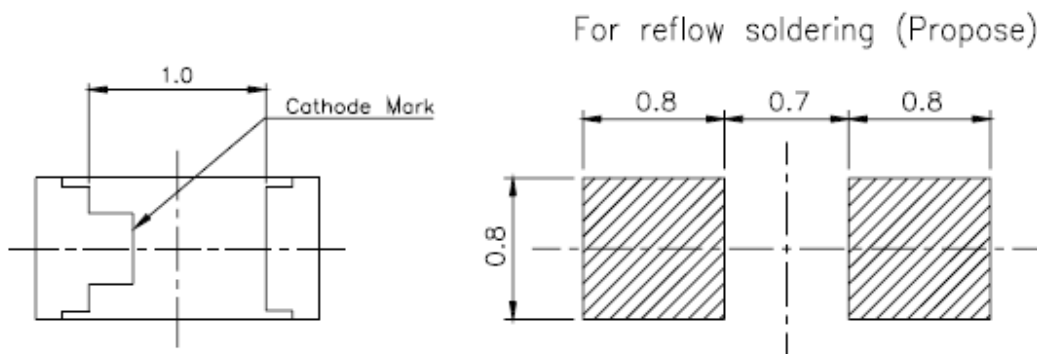

Note: The tolerances unless mentioned is ± 0.1 mm, Unit = mm

0603 Package 0.6mm Height Yellowish Green LED

TSP1-FF1608H6-2630

Carrier Tape Dimensions (Unit=mm): Loaded quantity 2000pcs per reel

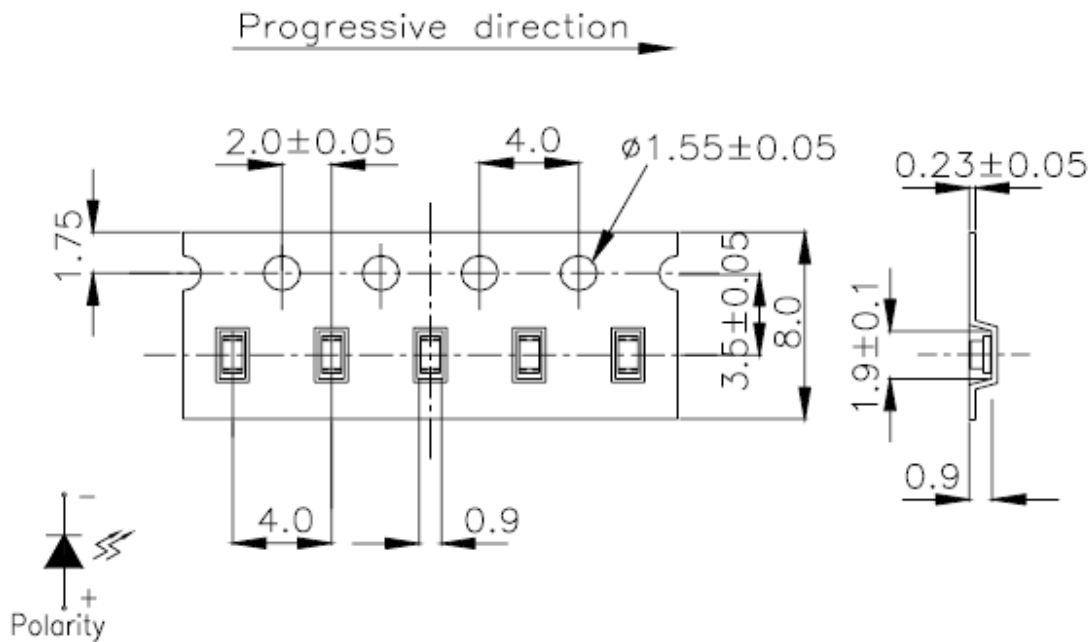

Note: The tolerances unless mentioned is ± 0.1 mm.

Moisture Resistant Packaging

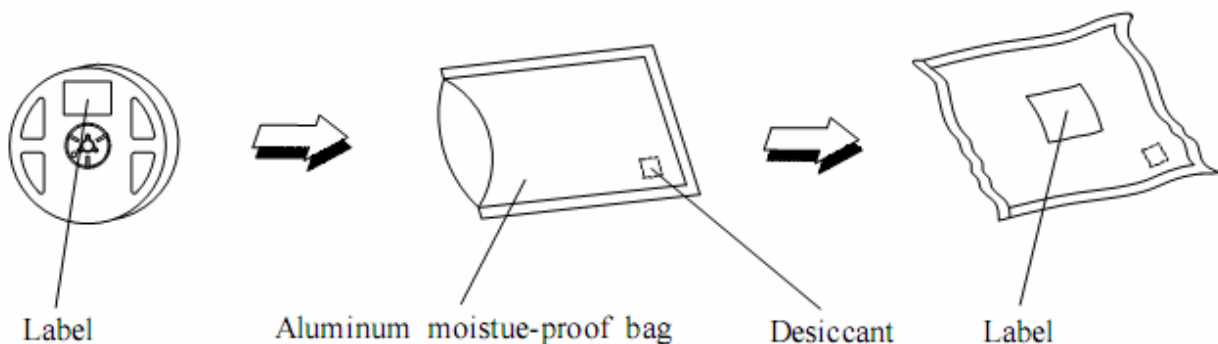

0603 Package 0.6mm Height Yellowish Green LED

TSP1-FF1608H6-2630

Reel Dimensions (Unit=mm):

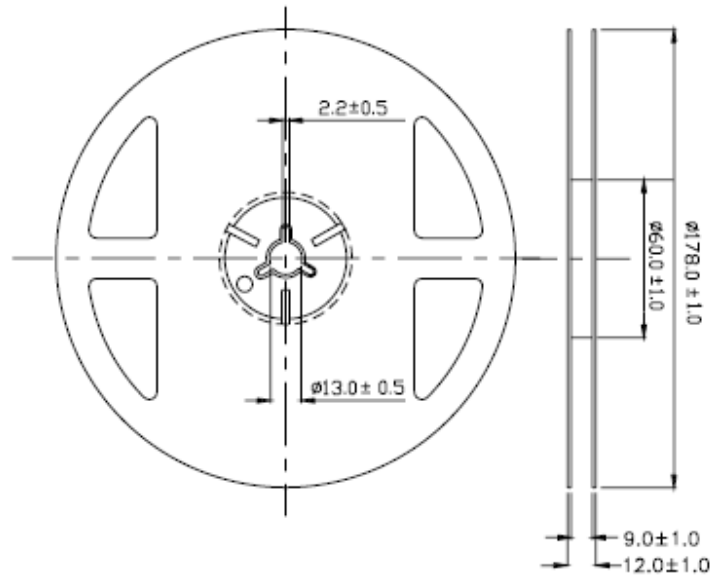

Note: The tolerances unless mentioned is ± 0.1 mm.

0603 Package 0.6mm Height Yellowish Green LED

TSP1-FF1608H6-2630

Ordering Information

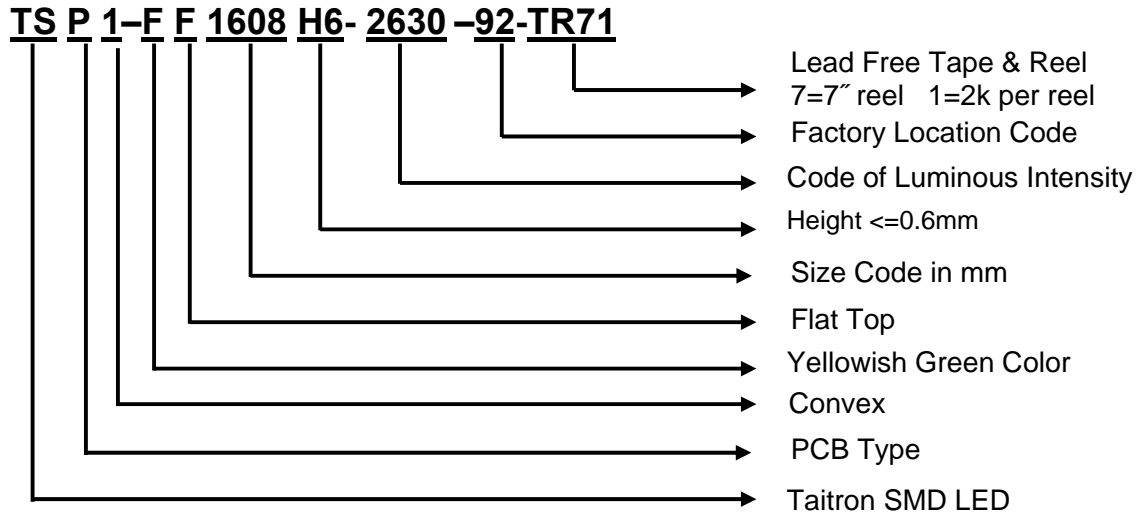

Label Explanation

CAT: Luminous Intensity Rank

HUE: Dom. Wavelength Rank

REF: Forward Voltage Rank

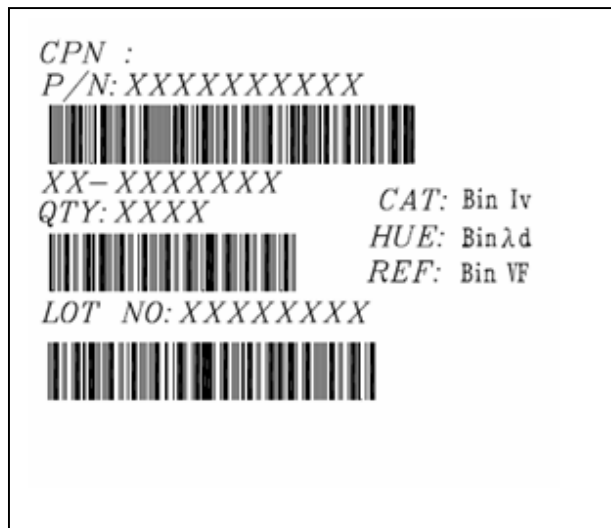

0603 Package 0.6mm Height Yellowish Green LED

TSP1-FF1608H6-2630

Bin Range of HUE

Groups	Bin Code	Min	Max	Unit	Condition
F	CC1	568.5	570.0	nm	IF=20mA
	CC2	570.0	571.5		
	CC3	571.5	573.0		
	CC4	573.0	574.5		

Bin Range of Luminous Intensity

Bin Code	Min	Max	Unit	Condition
26	35.0	40.5	mcd	IF=20mA
27	40.5	46.5		
28	46.5	53.5		
29	53.5	61.5		
30	61.5	70.7		

Bin Range of Forward Voltage

Groups	Bin Code	Min	Max	Unit	Condition
B	0	1.75	1.95	V	IF=20mA
	1	1.95	2.15		
	2	2.15	2.35		

Notes: Tolerance of Luminous Intensity $\pm 10\%$

Tolerance of Dominant wavelength $\pm 1\text{nm}$

Tolerance of Forward Voltage $\pm 0.1\text{V}$

0603 Package 0.6mm Height Yellowish Green LED

TSP1-FF1608H6-2630

How to contact us

US HEADQUARTER

28040 WEST HARRISON PARKWAY, VALENCIA, CA 91355-4162
Tel: (800) TAITRON (800) 824-8766 (661) 257-6060
Fax: (800) TAITFAX (800) 824-8329 (661) 257-6415
Email: taitron@taitroncomponents.com
Http://www.taitroncomponents.com

TAITRON COMPONENTS MEXICO, S.A .DE C.V.

BOULEVARD CENTRAL 5000 INTERIOR 5 PARQUE INDUSTRIAL ATITALAQUIA, HIDALGO
C.P. 42970 MEXICO
Tel: +52-55-5560-1519
Fax: +52-55-5560-2190

TAITRON COMPONETS INCORPORATED E REPRESENTAÇÕES DO BRASIL LTDA

RUA DOMINGOS DE MORAIS, 2777, 2.ANDAR, SALA 24 SAÚDE - SÃO PAULO-SP 04035-001
BRAZIL
Tel: +55-11-5574-7949
Fax: +55-11-5572-0052

TAITRON COMPONETS INCORPORATED, SHANGHAI REPRESENTATIVE OFFICE

METROBANK PLAZA, 1160 WEST YAN'AN ROAD, SUITE 1502, SHANGHAI 200052, CHINA.
Tel: +86-21-5424-9942
Fax: +86-21-5424-9931