

FEATURES

- **LOW INTERMODULATION DISTORTION**
 IM3=-45 dBc at Pout= 25.5dBm
 Single Carrier Level
- **HIGH POWER**
 P1dB=36.5dBm at 3.3GHz to 3.6GHz
- **HIGH GAIN**
 G1dB=10.0dB at 3.3GHz to 3.6GHz
- **BROAD BAND INTERNALLY MATCHED FET**
- **HERMETICALLY SEALED PACKAGE**

RF PERFORMANCE SPECIFICATIONS (Ta= 25°C)

CHARACTERISTICS	SYMBOL	CONDITIONS	UNIT	MIN.	TYP.	MAX.
Output Power at 1dB Gain Compression Point	P1dB	VDS= 10V f= 3.3 to 3.6GHz	dBm	35.5	36.5	—
Power Gain at 1dB Gain Compression Point	G1dB		dB	10.0	—	—
Drain Current	IDS1		A	—	1.1	1.3
Gain Flatness	ΔG		dB	—	—	±0.6
Power Added Efficiency	ηadd		%	—	37	—
3 rd Order Intermodulation Distortion	IM3	Two-Tone Test Po=25.5dBm	dBc	-42	-45	—
Drain Current	IDS2	(Single Carrier Level)	A	—	1.1	1.3
Channel Temperature Rise	ΔTch	(VDS X IDS + Pin - P1dB) X Rth(c-c)	°C	—	—	80

Recommended Gate Resistance(Rg): 150 Ω (Max.)

ELECTRICAL CHARACTERISTICS (Ta= 25°C)

CHARACTERISTICS	SYMBOL	CONDITIONS	UNIT	MIN.	TYP.	MAX.
Transconductance	gm	VDS= 3V IDS= 1.5A	mS	—	900	—
Pinch-off Voltage	VGSoff	VDS= 3V IDS= 15mA	V	-1.0	-2.5	-4.0
Saturated Drain Current	IDSS	VDS= 3V VGS= 0V	A	—	2.6	—
Gate-Source Breakdown Voltage	VGSO	IGS= -50μA	V	-5	—	—
Thermal Resistance	Rth(c-c)	Channel to Case	°C/W	—	4.5	6.5

◆ The information contained herein is presented only as a guide for the applications of our products. No responsibility is assumed by TOSHIBA for any infringements of patents or other rights of the third parties which may results from its use, No license is granted by implication or otherwise under any patent or patent rights of TOSHIBA or others.

The information contained herein is subject to change without prior notice. It is therefor advisable to contact TOSHIBA before proceeding with design of equipment incorporating this product.

ABSOLUTE MAXIMUM RATINGS (Ta= 25°C)

CHARACTERISTICS	SYMBOL	UNIT	RATING
Drain-Source Voltage	VDS	V	15
Gate-Source Voltage	VGS	V	-5
Drain Current	IDS	A	3.5
Total Power Dissipation (Tc= 25 °C)	PT	W	23.1
Channel Temperature	Tch	°C	175
Storage Temperature	Tstg	°C	-65 to +175

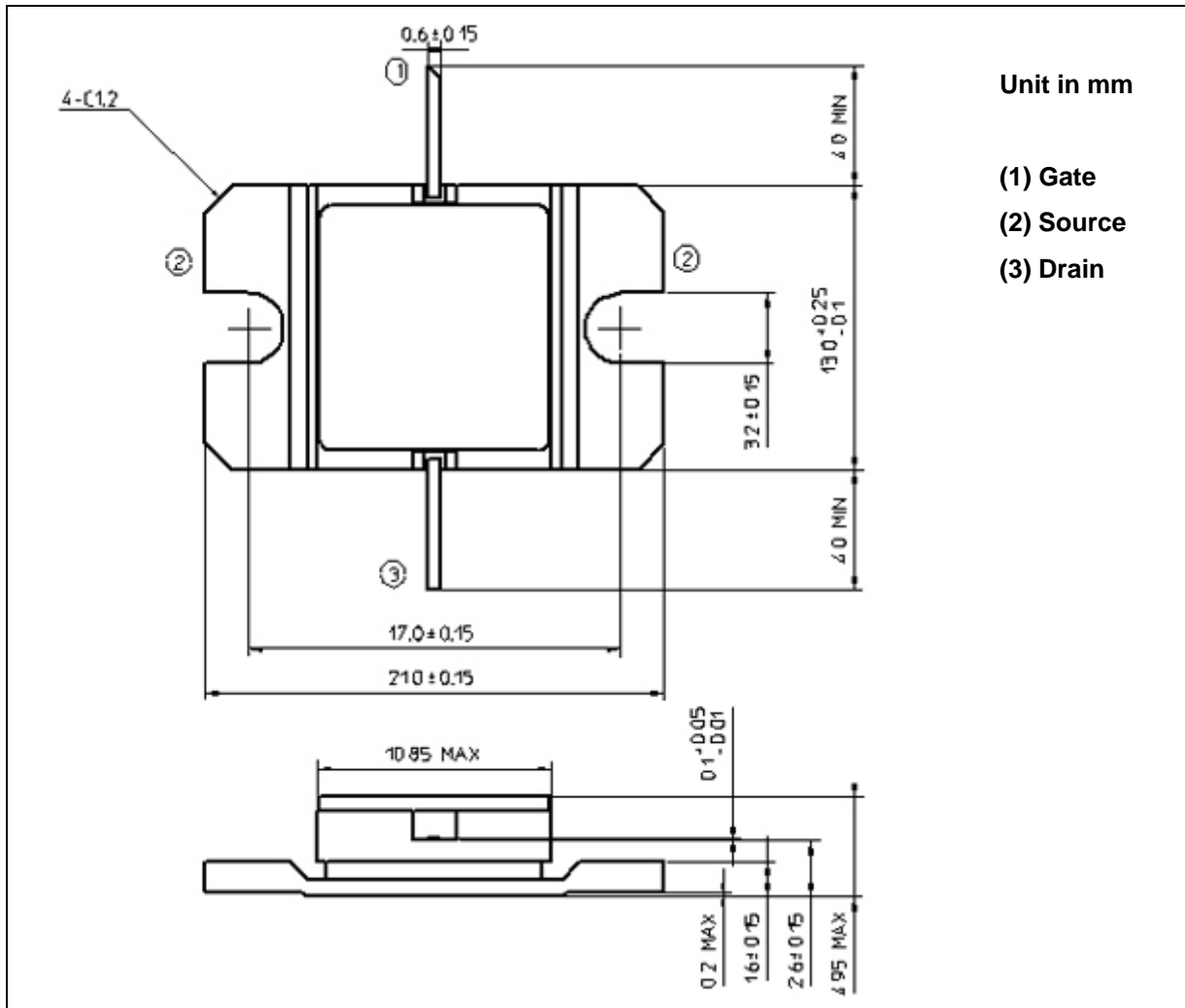
PACKAGE OUTLINE (2-11D1B)**HANDLING PRECAUTIONS FOR PACKAGE MODEL**

Soldering iron should be grounded and the operating time should not exceed 10 seconds at 260°C.

RF PERFORMANCE

Output Power (Pout) vs. Frequency

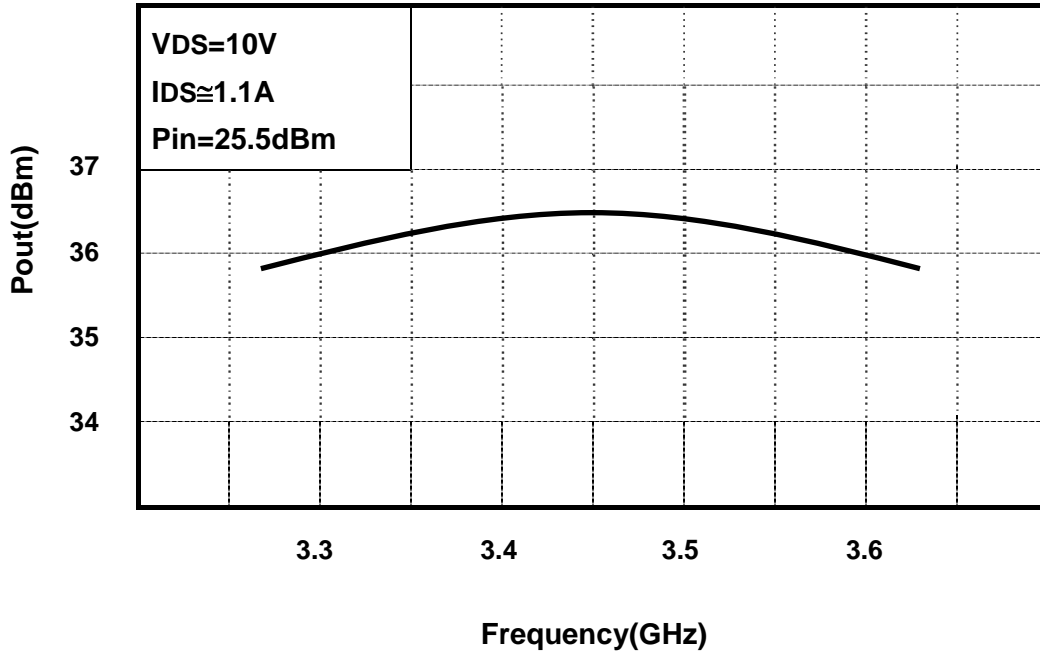

Output Power(Pout) vs. Input Power(Pin)

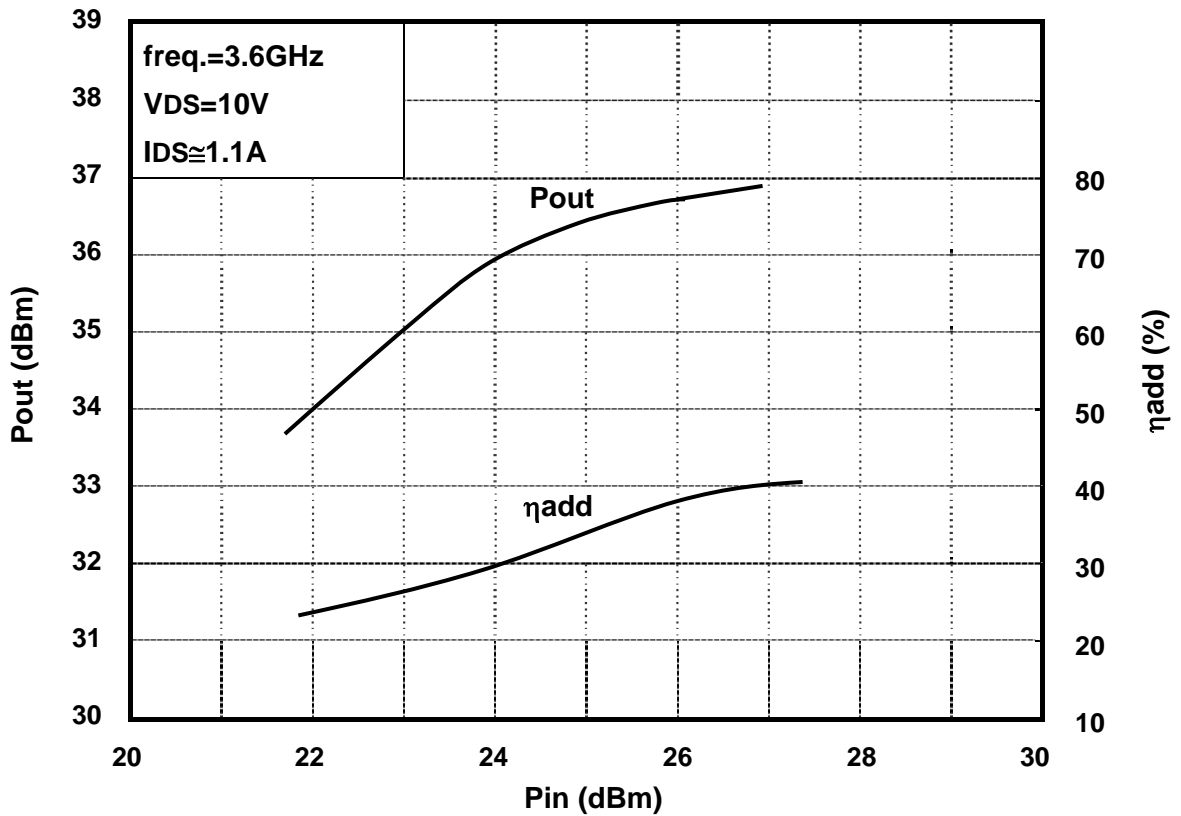

Power Dissipation vs. Case Temperature

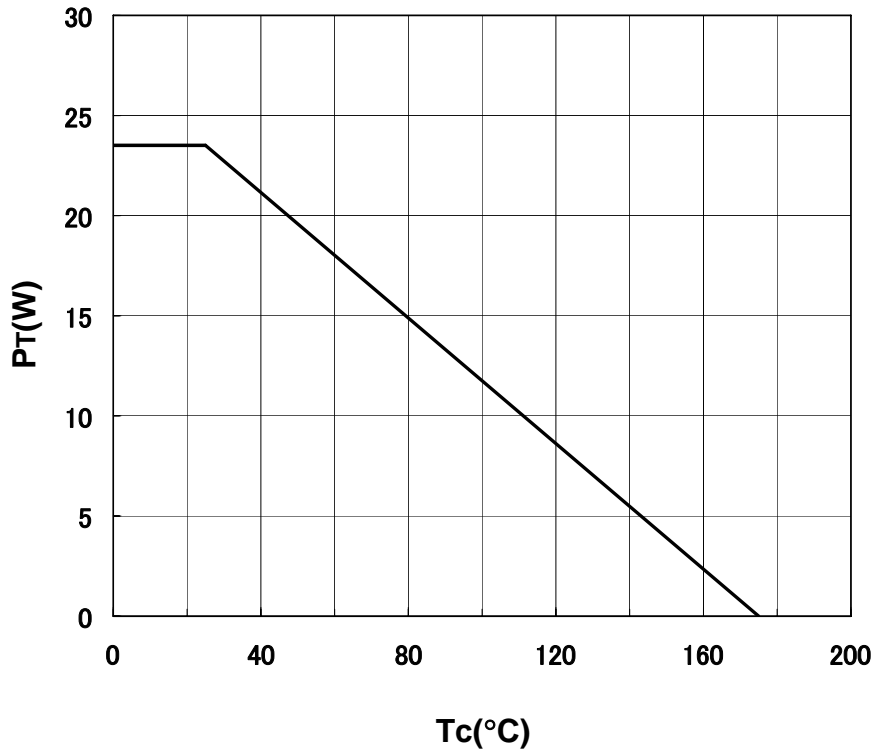

IM3 vs. Output Power Characteristics

