



SRAS820 - SRAS8150

8.0 AMPS. Surface Mount Schottky Barrier Rectifiers

D²PAK

Features

- ✧ For surface mounted application
- ✧ Ideal for automated pick & place
- ✧ Low power loss, high efficiency
- ✧ High current capability, low VF
- ✧ High reliability
- ✧ Epitaxial construction
- ✧ Guard-ring for transient protection

Mechanical Data

- ✧ Cases: D²PAK molded plastic
- ✧ Epoxy: UL 94V-0 rate flame retardant
- ✧ Terminals: Pure tin plated, lead free. solderable per MIL-STD-202, Method 208 guaranteed
- ✧ Polarity: As marked
- ✧ High temperature soldering guaranteed: 260°C/10 seconds/.25", (6.35mm) from case
- ✧ Weight: 2.24 grams

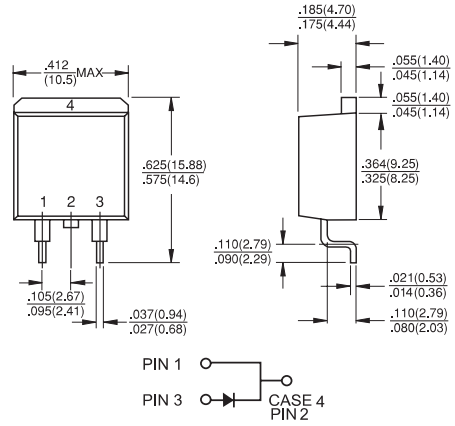

Dimensions in inches and (millimeters)

Maximum Ratings and Electrical Characteristics

Rating at 25°C ambient temperature unless otherwise specified.
Single phase, half wave, 60 Hz, resistive or inductive load.
For capacitive load, derate current by 20%

Type Number	Symbol	SRAS 820	SRAS 830	SRAS 840	SRAS 850	SRAS 860	SRAS 890	SRAS 8100	SRAS 8150	Units
Maximum Recurrent Peak Reverse Voltage	V_{RRM}	20	30	40	50	60	90	100	150	V
Maximum RMS Voltage	V_{RMS}	14	21	28	35	42	63	70	105	V
Maximum DC Blocking Voltage	V_{DC}	20	30	40	50	60	90	100	150	V
Maximum Average Forward Rectified Current See Fig. 1	$I_{(AV)}$	8.0								A
Peak Forward Surge Current, 8.3 ms Single Half Sine-wave Superimposed on Rated Load (JEDEC method)	I_{FSM}	150								A
Maximum Instantaneous Forward Voltage @ 8.0A	V_F	0.55		0.70		0.95			V	
Maximum D.C. Reverse Current @ $T_c=25^\circ\text{C}$ at Rated DC Blocking Voltage @ $T_c=125^\circ\text{C}$	I_R	0.1								mA
		5.0								mA
Typical Junction Capacitance (Note 2)	C_j	165								pF
Typical Thermal Resistance (Note 1)	$R_{\theta JC}$	3.0								°C/W
Operating Junction Temperature Range	T_J	-65 to +150								°C
Storage Temperature Range	T_{STG}	-65 to +150								°C

Notes: 1. Thermal Resistance from Junction to Case Per Leg
2. Measured at 1MHz and Applied Reverse Voltage of 4.0V D.C.

RATINGS AND CHARACTERISTIC CURVES (SRAS820 THRU SRAS8150)

FIG.1- MAXIMUM FORWARD CURRENT DERATING CURVE

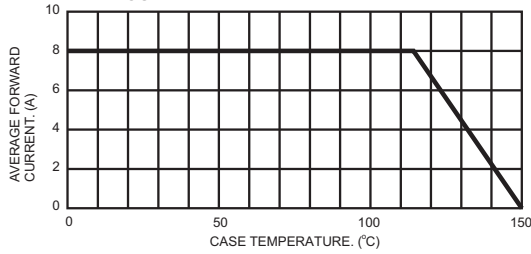

FIG.2- MAXIMUM NON-REPETITIVE FORWARD SURGE CURRENT

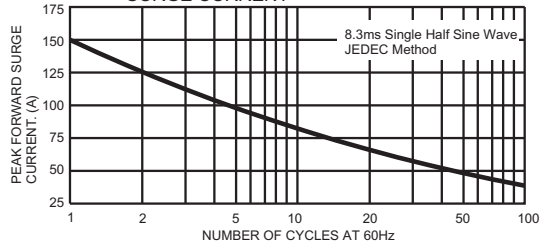

FIG.3- TYPICAL FORWARD CHARACTERISTICS

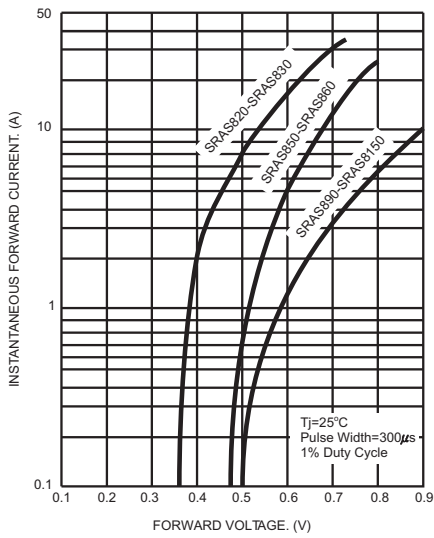

FIG.4- TYPICAL REVERSE CHARACTERISTICS

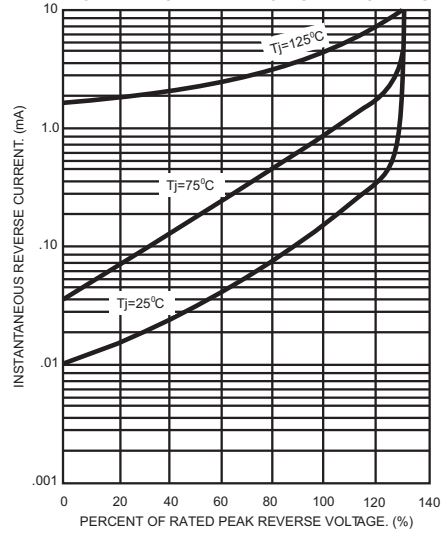

FIG.5- TYPICAL JUNCTION CAPACITANCE

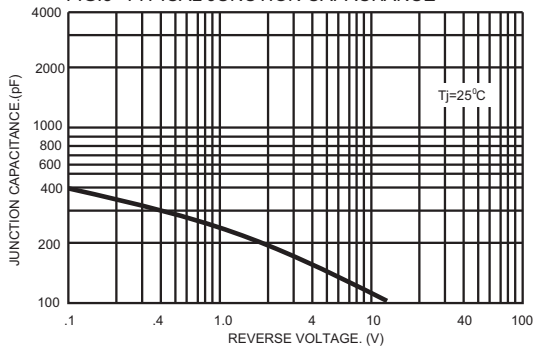

FIG.6- TYPICAL TRANSIENT THERMAL CHARACTERISTICS

