



STD1LNK60Z-1 STQ1NK60ZR - STN1NK60Z

N-CHANNEL 600V - 13Ω - 0.8A - TO-92 - IPAK - SOT-223
Zener-Protected SuperMESH™ Power MOSFET

General features

Type	V _{DSS}	R _{DS(on)}	I _D	P _w
STD1LNK60Z-1	600V	<15Ω	0.8A	25W
STQ1NK60ZR	600V	<15Ω	0.3A	3W
STN1NK60Z	600V	<15Ω	0.3A	3.3W

- 100% avalanche tested
- Extremely high dv/dt capability
- Gate charge minimized
- ESD improved capability
- New high voltage benchmark

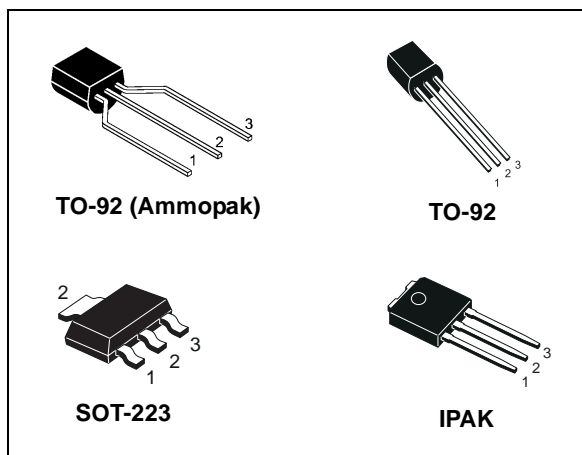

Description

The SuperMESH™ series is obtained through an extreme optimization of ST's well established strip-based PowerMESH™ layout. In addition to pushing on-resistance significantly down, special care is taken to ensure a very good dv/dt capability for the most demanding applications. Such series complements ST full range of high voltage MOSFETs including revolutionary MDmesh™ products.

Applications

- Switching application

Internal schematic diagram

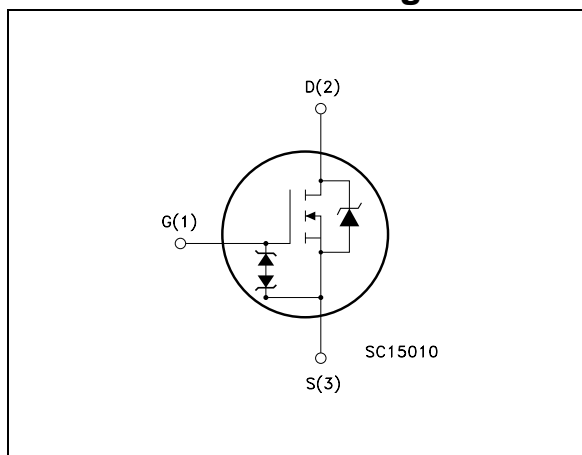

Order codes

Sales Type	Marking	Package	Packaging
STD1LNK60Z-1	D1LNK60Z	IPAK	TUBE
STQ1NK60ZR	Q1NK60ZR	TO-92	BULK
STQ1NK60ZR-AP	Q1NK60ZR	TO-92	AMMOPAK
STN1NK60Z	1NK60Z	SOT-223	TAPE & REEL

1 Electrical ratings

Table 1. Absolute maximum ratings

Symbol	Parameter	Value			Unit
		IPAK	TO-92	SOT-223	
V_{DS}	Drain-Source Voltage ($V_{GS} = 0$)	600			V
V_{DGR}	Drain-Gate Voltage ($R_{GS} = 20K\Omega$)	600			V
V_{GS}	Gate-Source Voltage	± 30			V
I_D	Drain Current (continuous) at $T_C = 25^\circ C$	0.8	0.3	0.3	A
I_D	Drain Current (continuous) at $T_C=100^\circ C$	0.5	0.189		A
$I_{DM}^{(1)}$	Drain Current (pulsed)	3.2	1.2		A
P_{TOT}	Total Dissipation at $T_C = 25^\circ C$	25	3	3.3	W
	Derating Factor	0.24	0.25	0.26	W/ $^\circ C$
$V_{ESD(G-D)}$	Gate source ESD(HBM-C=100pF, R=1.5K Ω)	800			V
$dv/dt^{(2)}$	Peak Diode Recovery voltage slope	4.5			V/ns
T_J T_{stg}	Operating Junction Temperature Storage Temperature	-55 to 150			$^\circ C$

1. Pulse width limited by safe operating area
2. $I_{SD} \leq 0.3A$, $di/dt \leq 200A/\mu s$, $V_{DD} = 80\%V_{(BR)DSS}$

Table 2. Thermal resistance

Symbol	Parameter	Value			Unit
		IPAK	TO-92	SOT-223	
$R_{thj-case}$	Thermal resistance junction-case Max	5	--	--	$^\circ C/W$
R_{thj-a}	Thermal resistance junction-ambient Max	100	120	37.87 ⁽¹⁾	$^\circ C/W$
$R_{thj-lead}$	Thermal resistance junction-lead Max	--	40	--	$^\circ C/W$
T_l	Maximum lead temperature for soldering purpose	275	260		$^\circ C$

1. When mounted on 1 inch² FR-4 board, 2 Oz Cu

Table 3. Avalanche data

Symbol	Parameter	Value	Unit
I_{AR}	Avalanche Current, Repetitive or Noy-Repetitive (pulse width limited by T_j Max)	0.8	A
E_{AS}	Single pulse avalanche Energy (starting $T_j=25^\circ C$, $I_d=I_{ar}$, $V_{dd}=50V$)	60	mJ

2 Electrical characteristics

(T_{CASE}=25°C unless otherwise specified)

Table 4. On/off states

Symbol	Parameter	Test Conditions	Min.	Typ.	Max.	Unit
V _{(BR)DSS}	Drain-Source Breakdown Voltage	I _D = 1mA, V _{GS} = 0	600			V
I _{DSS}	Zero Gate Voltage Drain Current (V _{GS} = 0)	V _{DS} = Max Rating, V _{DS} = MaxRating @125°C			1 50	μA μA
I _{GSS}	Gate Body Leakage Current (V _{DS} = 0)	V _{GS} = ±20V			±10	μA
V _{GS(th)}	Gate Threshold Voltage	V _{DS} = V _{GS} , I _D = 50μA	3	3.75	4.5	V
R _{DS(on)}	Static Drain-Source On Resistance	V _{GS} = 10V, I _D = 0.4A		13	15	Ω

Table 5. Dynamic

Symbol	Parameter	Test Conditions	Min.	Typ.	Max.	Unit
g _{fs} ⁽¹⁾	Forward Transconductance	V _{DS} =15V, I _D = 0.4A		0.5		S
C _{iss} C _{oss} C _{rss}	Input Capacitance Output Capacitance Reverse Transfer Capacitance	V _{DS} =25V, f=1 MHz, V _{GS} =0		94 17.6 2.8		pF pF pF
C _{oss eq} ⁽²⁾	Equivalent Output Capacitance	V _{GS} =0, V _{DS} =0V to 480V		11		pF
Q _g Q _{gs} Q _{gd}	Total Gate Charge Gate-Source Charge Gate-Drain Charge	V _{DD} =480V, I _D = 0.8A V _{GS} =10V (see Figure 11)		4.9 1 2.7	6.9	nC nC nC

1. Pulsed: pulse duration=300μs, duty cycle 1.5%
2. C_{oss eq} is defined as a constant equivalent capacitance giving the same charging time as C_{oss} when V_{DS} increases from 0 to 80% V_{DSS}

Table 6. Switching times

Symbol	Parameter	Test Conditions	Min.	Typ.	Max.	Unit
$t_{d(on)}$	Turn-on Delay Time	$V_{DD}=300\text{ V}$, $I_D=0.4\text{ A}$, $R_G=4.7\Omega$, $V_{GS}=10\text{ V}$ (see Figure 19)		5.5		ns
t_r	Rise Time			5		ns
$t_{d(off)}$	Turn-off Delay Time			13		ns
t_f	Fall Time			28		ns

Table 7. Source drain diode

Symbol	Parameter	Test Conditions	Min	Typ.	Max	Unit
I_{SD}	Source-drain Current				0.8	A
$I_{SDM}^{(1)}$	Source-drain Current (pulsed)				2.4	A
$V_{SD}^{(2)}$	Forward on Voltage	$I_{SD}=0.8\text{ A}$, $V_{GS}=0$			1.6	V
t_{rr}	Reverse Recovery Time	$I_{SD}=0.8\text{ A}$, $di/dt = 100\text{ A}/\mu\text{s}$, $V_{DD}=20\text{ V}$, $T_j=25^\circ\text{C}$		135		ns
Q_{rr}	Reverse Recovery Charge			216		nC
I_{RRM}	Reverse Recovery Current			3.2		A
t_{rr}	Reverse Recovery Time	$I_{SD}=0.8\text{ A}$, $di/dt = 100\text{ A}/\mu\text{s}$, $V_{DD}=20\text{ V}$, $T_j=150^\circ\text{C}$		140		ns
Q_{rr}	Reverse Recovery Charge			224		nC
I_{RRM}	Reverse Recovery Current			3.2		A

1. Pulse width limited by safe operating area
2. Pulsed: pulse duration=300 μs , duty cycle 1.5%

Table 8. Gate-source zener diode

Symbol	Parameter	Test Conditions	Min.	Typ.	Max.	Unit
$BV_{GSO}^{(1)}$	Gate-source Braekdown Voltage	$I_{gs}=\pm 1\text{ mA}$ (Open Drain)	30			V

1. The built-in back-to-back Zener diodes have specifically been designed to enhance not only the device's ESD capability, but also to make them safely absorb possible voltage transients that may occasionally be applied from gate to source. In this respect the Zener voltage is appropriate to achieve an efficient and cost-effective intervention to protect the device's integrity. These integrated Zener diodes thus avoid the usage of external components.

2.1 Electrical characteristics (curves)

Figure 1. Safe operating area for IPAK

Figure 2. Thermal impedance for IPAK

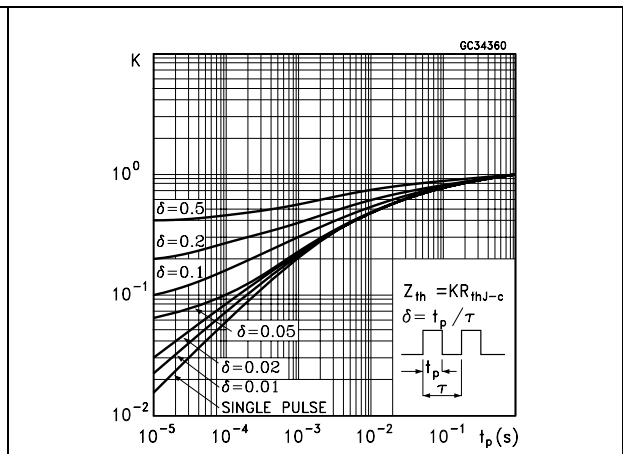
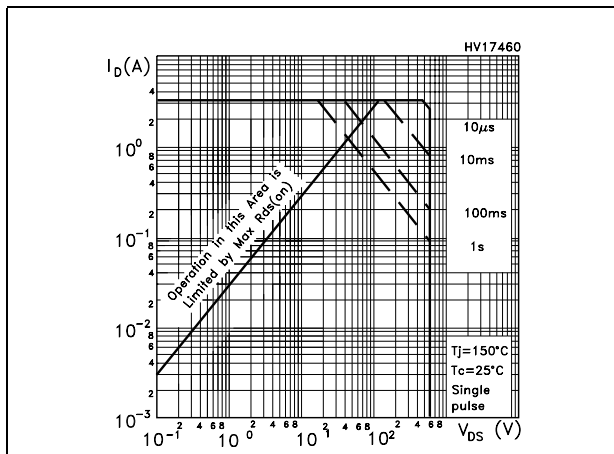

Figure 3. Safe operating area for TO-92

Figure 4. Thermal impedance for TO-92

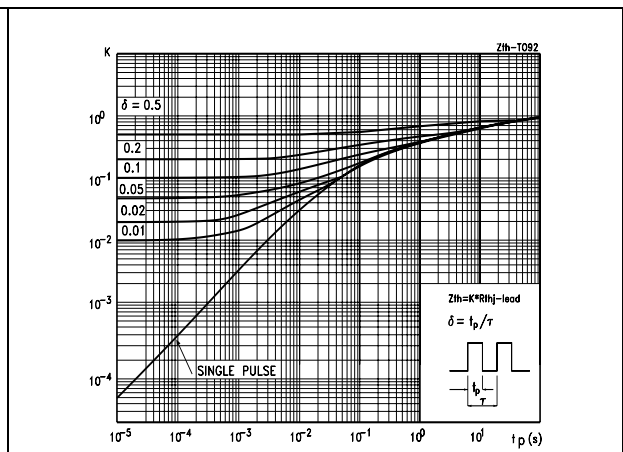
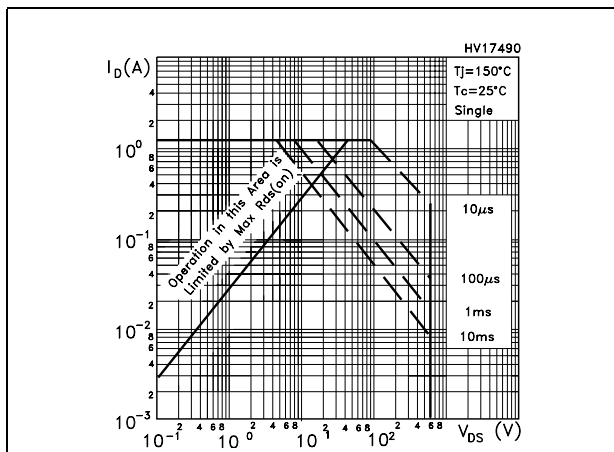

Figure 5. Safe operating area for SOT-223

Figure 6. Thermal impedance for SOT-223

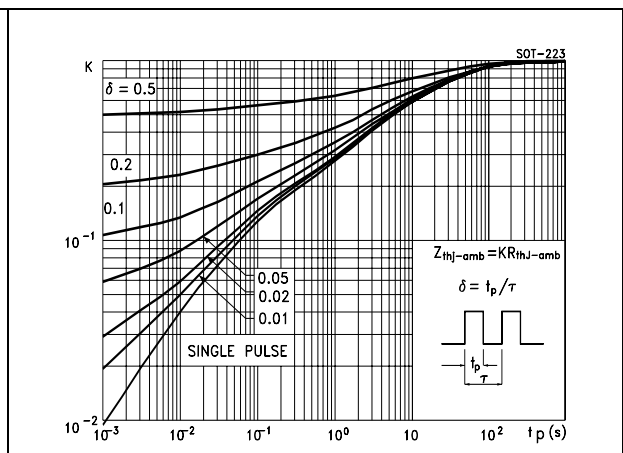
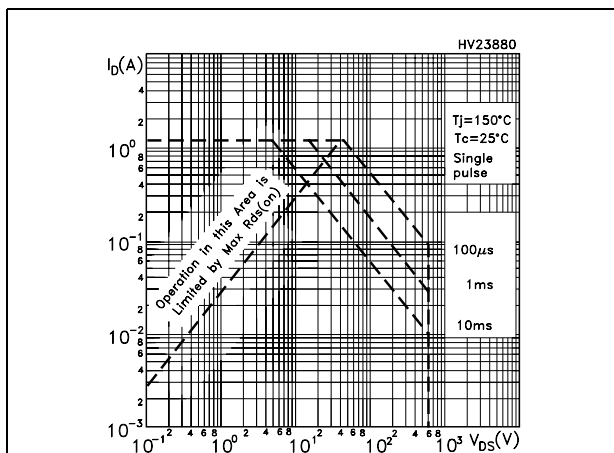

Figure 7. Output characteristics

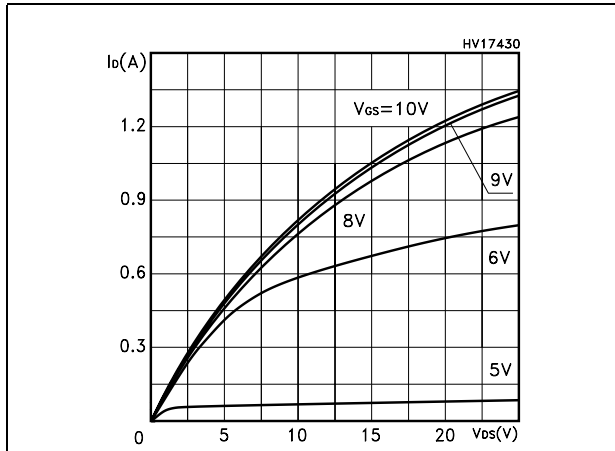

Figure 8. Transfer characteristics

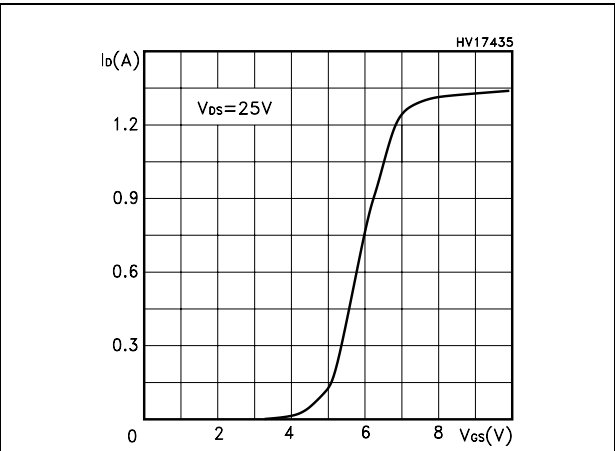

Figure 9. Transconductance

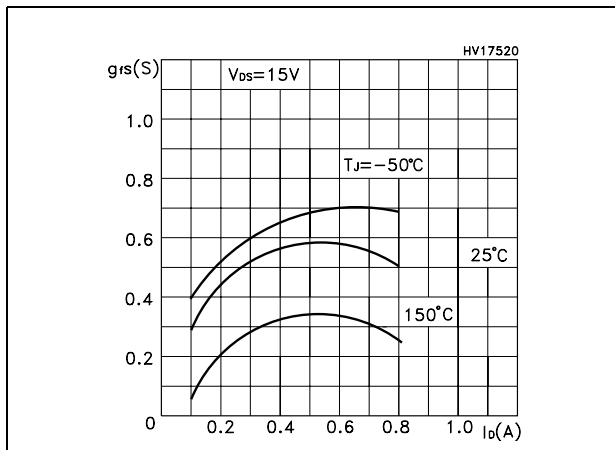

Figure 10. Static drain-source on resistance

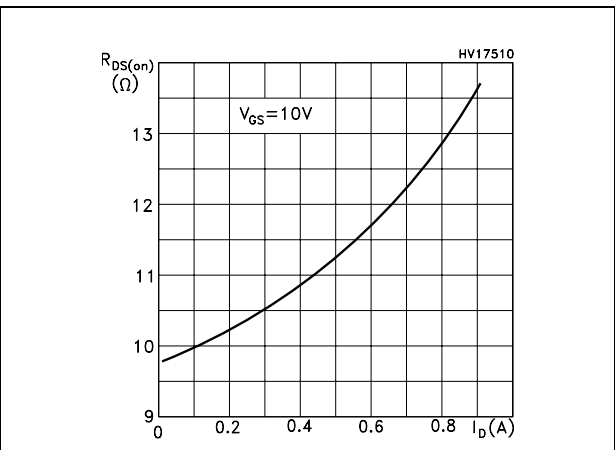

Figure 11. Gate charge vs gate-source voltage

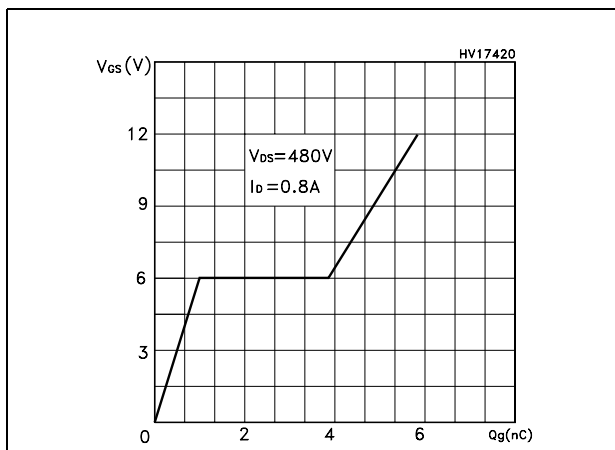

Figure 12. Capacitance variations

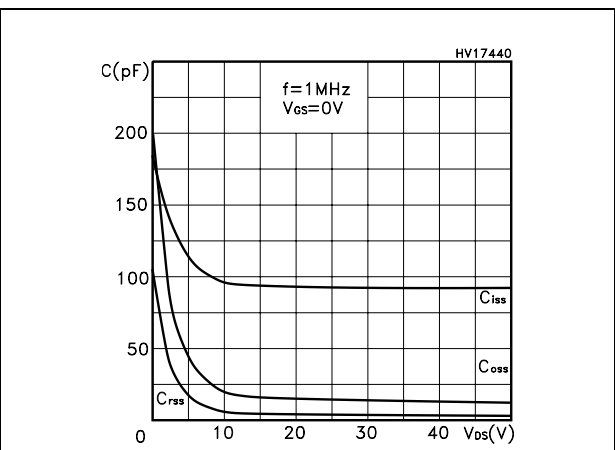

Figure 13. Normalized gate threshold voltage vs temperature

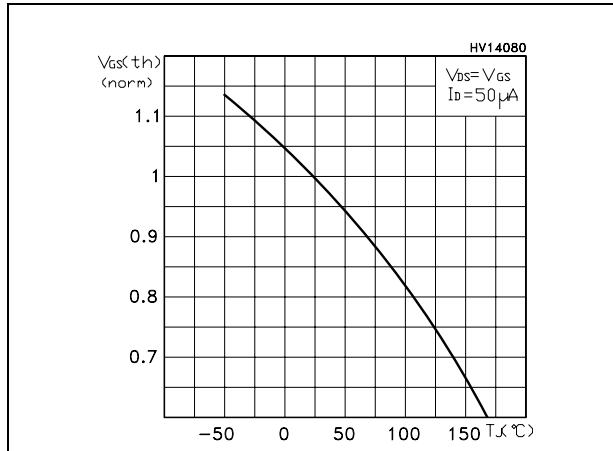

Figure 14. Normalized on resistance vs temperature

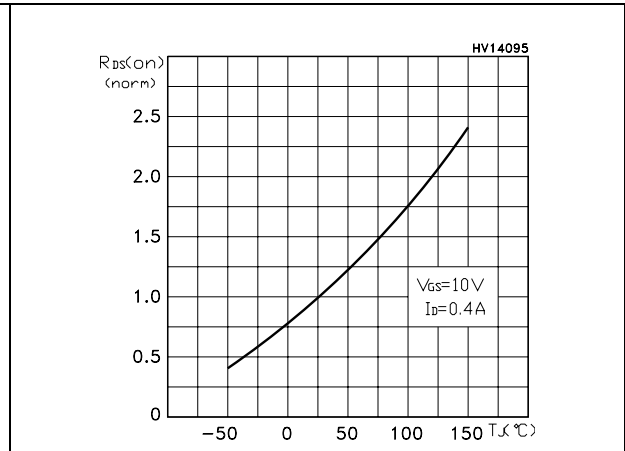

Figure 15. Source-drain diode forward characteristics

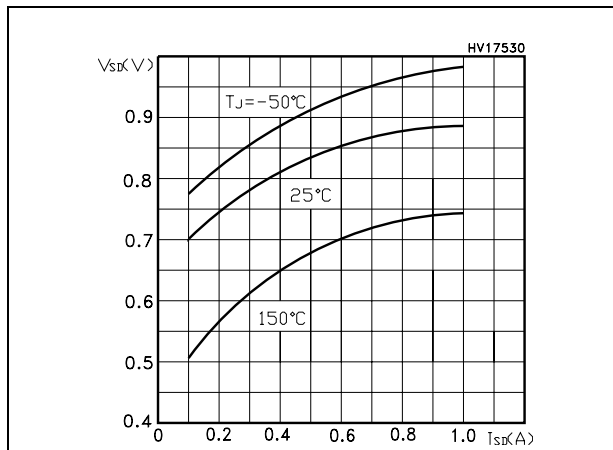

Figure 16. Normalized BV_{DSS} vs temperature

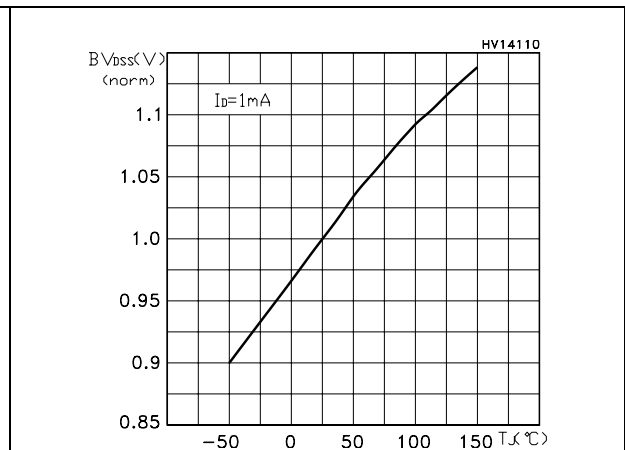

Figure 17. Maximum avalanche energy vs temperature

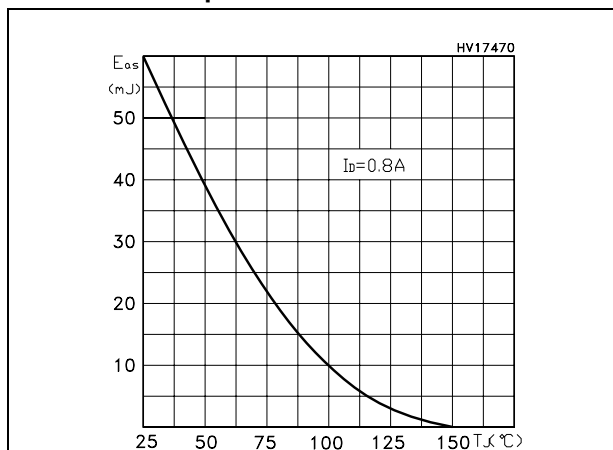
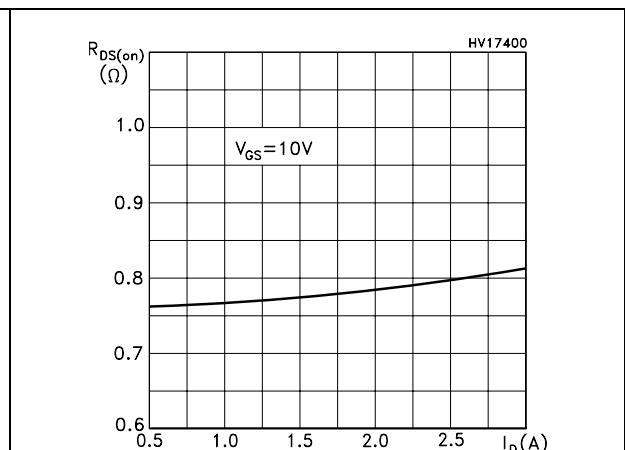

Figure 18. Max Id Current vs Tc



3 Test circuit

Figure 19. Switching times test circuit for resistive load

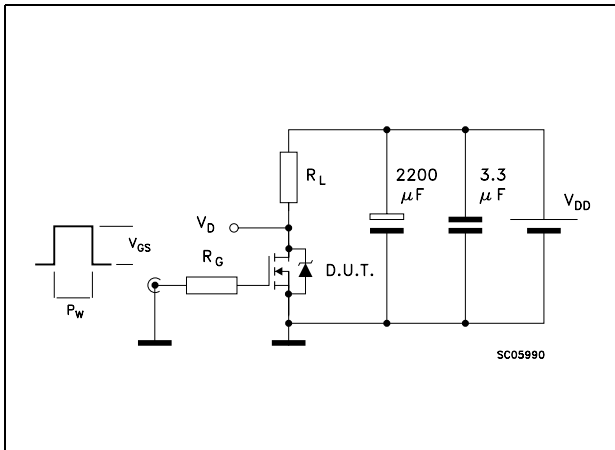

Figure 20. Gate charge test circuit

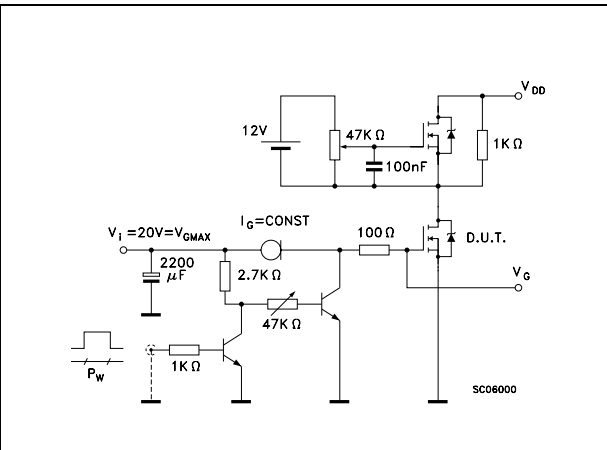

Figure 21. Test circuit for inductive load switching and diode recovery times

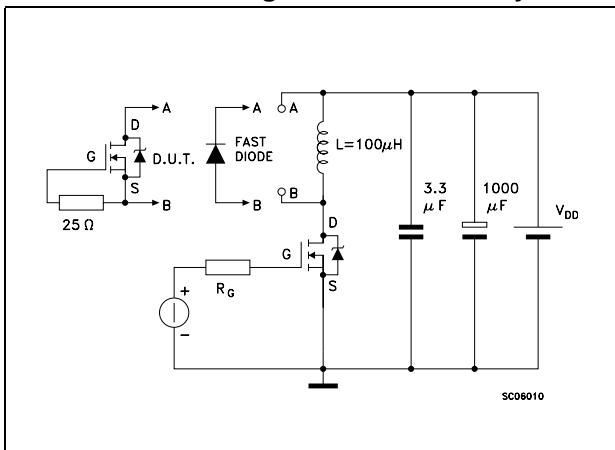

Figure 22. Unclamped Inductive load test circuit

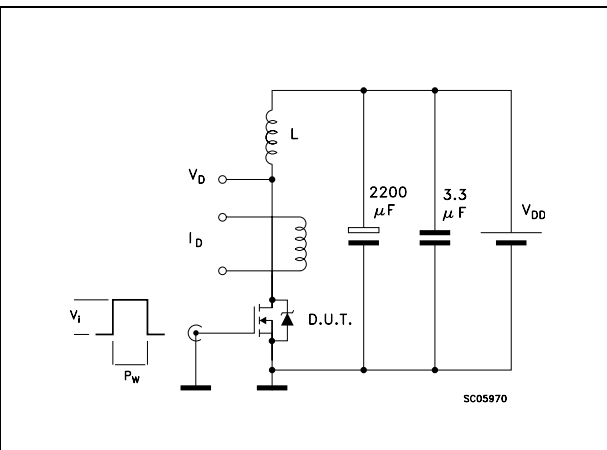

Figure 23. Unclamped inductive waveform

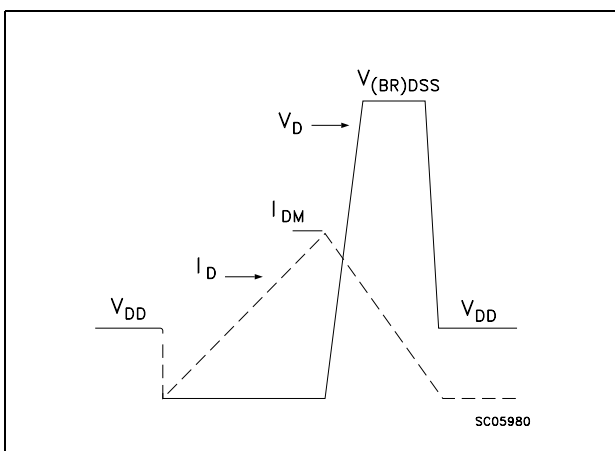
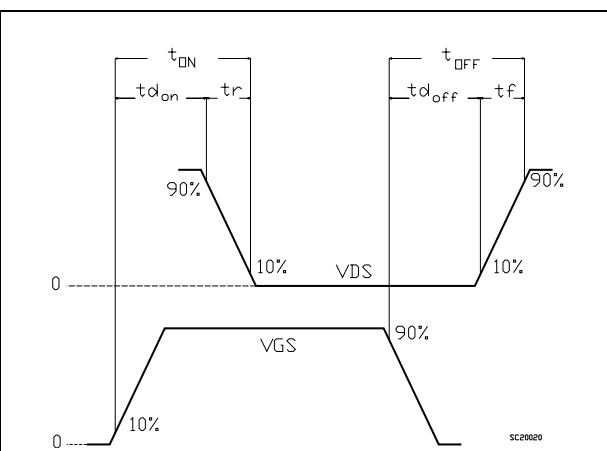

Figure 24. Switching time waveform



4 Package mechanical data

In order to meet environmental requirements, ST offers these devices in ECOPACK® packages. These packages have a Lead-free second level interconnect . The category of second level interconnect is marked on the package and on the inner box label, in compliance with JEDEC Standard JESD97. The maximum ratings related to soldering conditions are also marked on the inner box label. ECOPACK is an ST trademark. ECOPACK specifications are available at: www.st.com

TO-92 MECHANICAL DATA

DIM.	mm.			inch		
	MIN.	TYP	MAX.	MIN.	TYP.	MAX.
A	4.32		4.95	0.170		0.194
b	0.36		0.51	0.014		0.020
D	4.45		4.95	0.175		0.194
E	3.30		3.94	0.130		0.155
e	2.41		2.67	0.094		0.105
e1	1.14		1.40	0.044		0.055
L	12.70		15.49	0.50		0.610
R	2.16		2.41	0.085		0.094
S1	0.92		1.52	0.036		0.060
W	0.41		0.56	0.016		0.022
V		5°			5°	

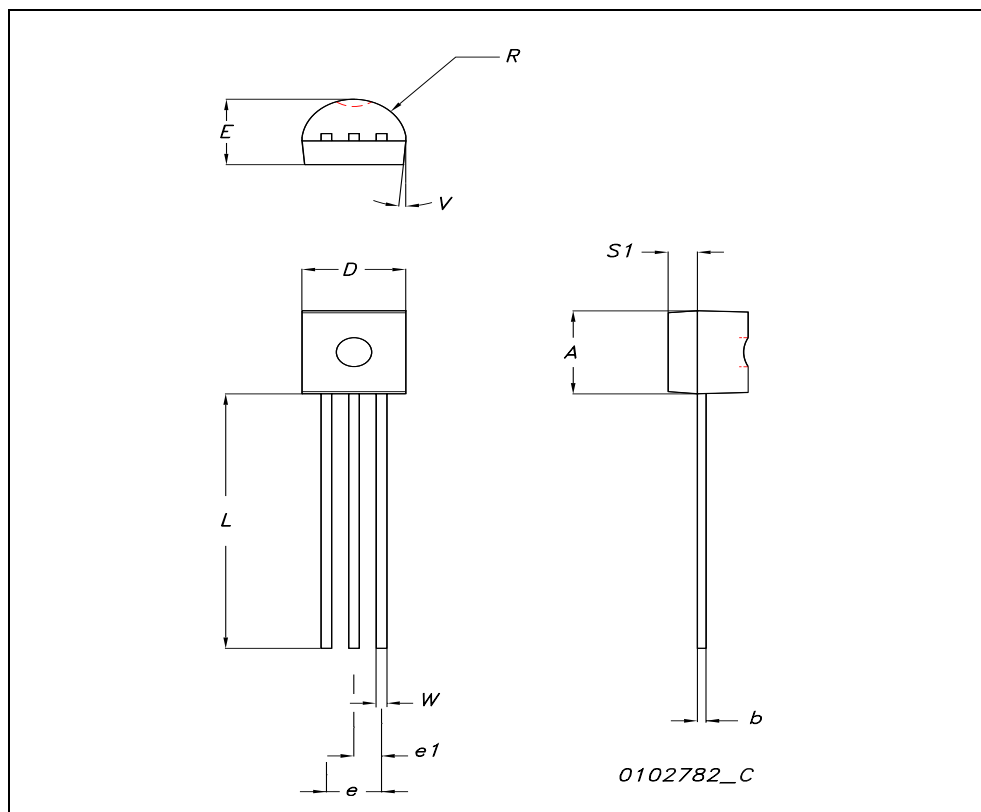

TO-251 (IPAK) MECHANICAL DATA

DIM.	mm			inch		
	MIN.	TYP.	MAX.	MIN.	TYP.	MAX.
A	2.2		2.4	0.086		0.094
A1	0.9		1.1	0.035		0.043
A3	0.7		1.3	0.027		0.051
B	0.64		0.9	0.025		0.031
B2	5.2		5.4	0.204		0.212
B3			0.85			0.033
B5		0.3			0.012	
B6			0.95			0.037
C	0.45		0.6	0.017		0.023
C2	0.48		0.6	0.019		0.023
D	6		6.2	0.236		0.244
E	6.4		6.6	0.252		0.260
G	4.4		4.6	0.173		0.181
H	15.9		16.3	0.626		0.641
L	9		9.4	0.354		0.370
L1	0.8		1.2	0.031		0.047
L2		0.8	1		0.031	0.039

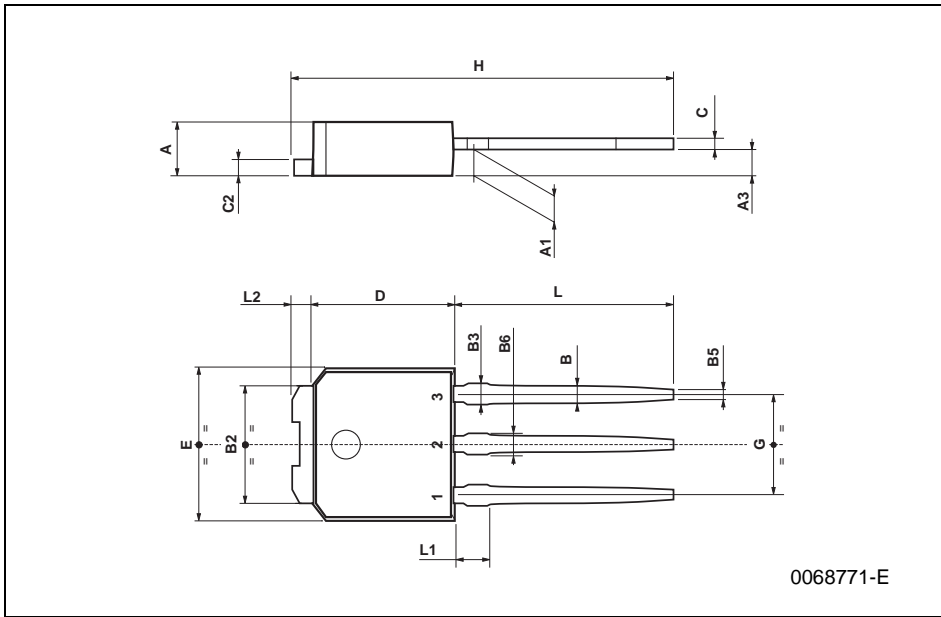

SOT-223 MECHANICAL DATA

DIM.	mm			mils		
	MIN.	TYP.	MAX.	MIN.	TYP.	MAX.
a	2.27	2.3	2.33	89.4	90.6	91.7
b	4.57	4.6	4.63	179.9	181.1	182.3
c	0.2	0.4	0.6	7.9	15.7	23.6
d	0.63	0.65	0.67	24.8	25.6	26.4
e1	1.5	1.6	1.7	59.1	63	66.9
e4			0.32			12.6
f	2.9	3	3.1	114.2	118.1	122.1
g	0.67	0.7	0.73	26.4	27.6	28.7
l1	6.7	7	7.3	263.8	275.6	287.4
l2	3.5	3.5	3.7	137.8	137.8	145.7
L	6.3	6.5	6.7	248	255.9	263.8

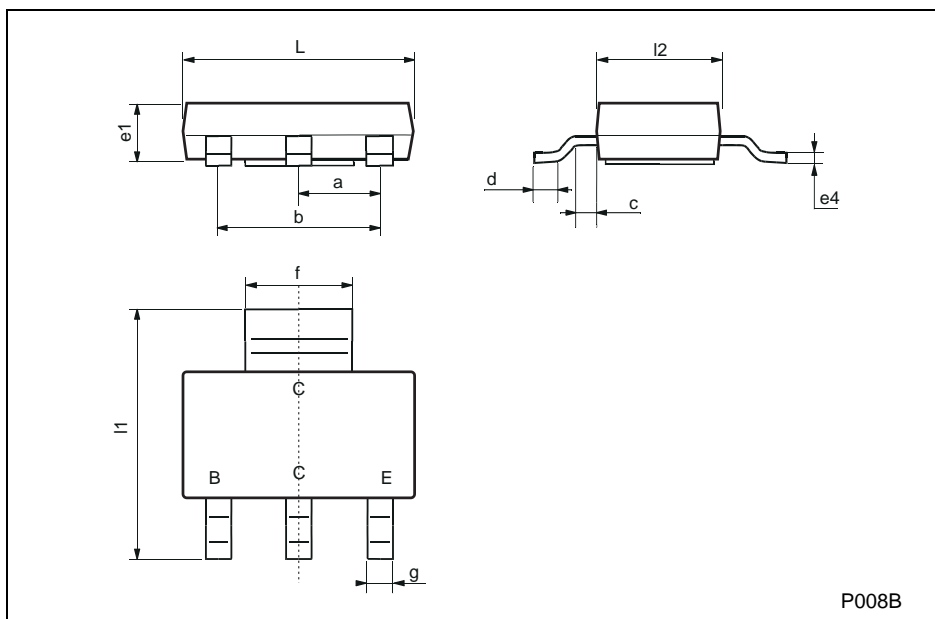

5 Revision history

Table 9. Revision history

Date	Revision	Changes
19-Mar-2003	1	First Release
15-May-2003	2	Removed DPAK
09-Jun-2003	3	Final datasheet
17-Nov-2004	4	Inserted SOT-223
15-Feb-2005	5	Modified Figure 3 .
07-Sep-2005	6	Inserted ecopak indication
22-Feb-2006	7	New template

Please Read Carefully:

Information in this document is provided solely in connection with ST products. STMicroelectronics NV and its subsidiaries ("ST") reserve the right to make changes, corrections, modifications or improvements, to this document, and the products and services described herein at any time, without notice.

All ST products are sold pursuant to ST's terms and conditions of sale.

Purchasers are solely responsible for the choice, selection and use of the ST products and services described herein, and ST assumes no liability whatsoever relating to the choice, selection or use of the ST products and services described herein.

No license, express or implied, by estoppel or otherwise, to any intellectual property rights is granted under this document. If any part of this document refers to any third party products or services it shall not be deemed a license grant by ST for the use of such third party products or services, or any intellectual property contained therein or considered as a warranty covering the use in any manner whatsoever of such third party products or services or any intellectual property contained therein.

UNLESS OTHERWISE SET FORTH IN ST'S TERMS AND CONDITIONS OF SALE ST DISCLAIMS ANY EXPRESS OR IMPLIED WARRANTY WITH RESPECT TO THE USE AND/OR SALE OF ST PRODUCTS INCLUDING WITHOUT LIMITATION IMPLIED WARRANTIES OF MERCHANTABILITY, FITNESS FOR A PARTICULAR PURPOSE (AND THEIR EQUIVALENTS UNDER THE LAWS OF ANY JURISDICTION), OR INFRINGEMENT OF ANY PATENT, COPYRIGHT OR OTHER INTELLECTUAL PROPERTY RIGHT.

UNLESS EXPRESSLY APPROVED IN WRITING BY AN AUTHORIZED REPRESENTATIVE OF ST, ST PRODUCTS ARE NOT DESIGNED, AUTHORIZED OR WARRANTED FOR USE IN MILITARY, AIR CRAFT, SPACE, LIFE SAVING, OR LIFE SUSTAINING APPLICATIONS, NOR IN PRODUCTS OR SYSTEMS, WHERE FAILURE OR MALFUNCTION MAY RESULT IN PERSONAL INJURY, DEATH, OR SEVERE PROPERTY OR ENVIRONMENTAL DAMAGE.

Resale of ST products with provisions different from the statements and/or technical features set forth in this document shall immediately void any warranty granted by ST for the ST product or service described herein and shall not create or extend in any manner whatsoever, any liability of ST.

ST and the ST logo are trademarks or registered trademarks of ST in various countries.

Information in this document supersedes and replaces all information previously supplied.

The ST logo is a registered trademark of STMicroelectronics. All other names are the property of their respective owners.

© 2006 STMicroelectronics - All rights reserved

STMicroelectronics group of companies

Australia - Belgium - Brazil - Canada - China - Czech Republic - Finland - France - Germany - Hong Kong - India - Israel - Italy - Japan - Malaysia - Malta - Morocco - Singapore - Spain - Sweden - Switzerland - United Kingdom - United States of America

www.st.com