

NX3L1T3157

Low-ohmic, single-pole, double-throw switch

Rev. 01 — 3 January 2008

Product data sheet

1. General description

The NX3L1T3157 provides one, low-ohmic, single-pole, double-throw analog switch suitable for use as an analog or digital multiplexer/demultiplexer. It has a digital select input (S) with Schmitt trigger action, two independent inputs/outputs (Y0, Y1) and a common input/output (Z).

Schmitt trigger action at the select input (S) makes the circuit tolerant to slower input rise and fall times across the entire V_{CC} range from 1.4 V to 3.6 V.

A low input voltage threshold allows pin S to be driven by lower level logic signals without a significant increase in supply current I_{CC} . This makes it possible for the NX3L1T3157 to switch 3.6 V signals with a 1.8 V digital controller, eliminating the need for logic level translation.

The NX3L1T3157 allows signals with amplitude up to V_{CC} to be transmitted from Z to Y0 or Y1; or from Y0 or Y1 to Z. Its low ON resistance (0.5 Ω) and flatness (0.13 Ω) ensures minimal attenuation and distortion of transmitted signals.

2. Features

- Wide supply voltage range from 1.4 V to 3.6 V
- Very low ON resistance (peak):
 - ◆ 1.6 Ω (typical) at $V_{CC} = 1.4$ V
 - ◆ 1.0 Ω (typical) at $V_{CC} = 1.65$ V
 - ◆ 0.55 Ω (typical) at $V_{CC} = 2.3$ V
 - ◆ 0.50 Ω (typical) at $V_{CC} = 2.7$ V
- Break-before-make switching
- High noise immunity
- ESD protection:
 - ◆ HBM JESD22-A114E Class 3A exceeds 7500 V
 - ◆ MM JESD22-A115-A exceeds 200 V
 - ◆ CDM AEC-Q100-011 revision B exceeds 1000 V
- CMOS low-power consumption
- Latch-up performance exceeds 100 mA per JESD 78 Class II Level B
- Direct interface with TTL levels at 3.0 V
- Control input accepts voltages above supply voltage
- Very low supply current, even when input is below V_{CC}
- High current handling capability (350 mA continuous current under 3.3 V supply)
- Specified from -40 °C to $+85$ °C and from -40 °C to $+125$ °C

3. Applications

- Cell phone
- PDA
- Portable media player

4. Ordering information

Table 1. Ordering information

Type number	Package			Version
	Temperature range	Name	Description	
NX3L1T3157GM	-40 °C to +125 °C	XSON6	plastic extremely thin small outline package; no leads; 6 terminals; body 1 × 1.45 × 0.5 mm	SOT886

5. Marking

Table 2. Marking

Type number	Marking code
NX3L1T3157GM	MI

6. Functional diagram

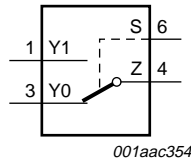

Fig 1. Logic symbol

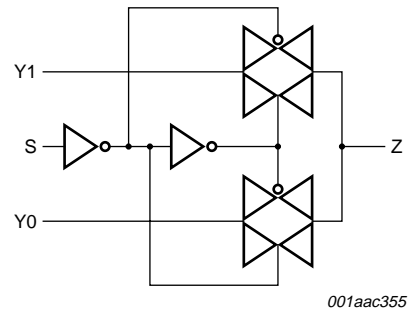
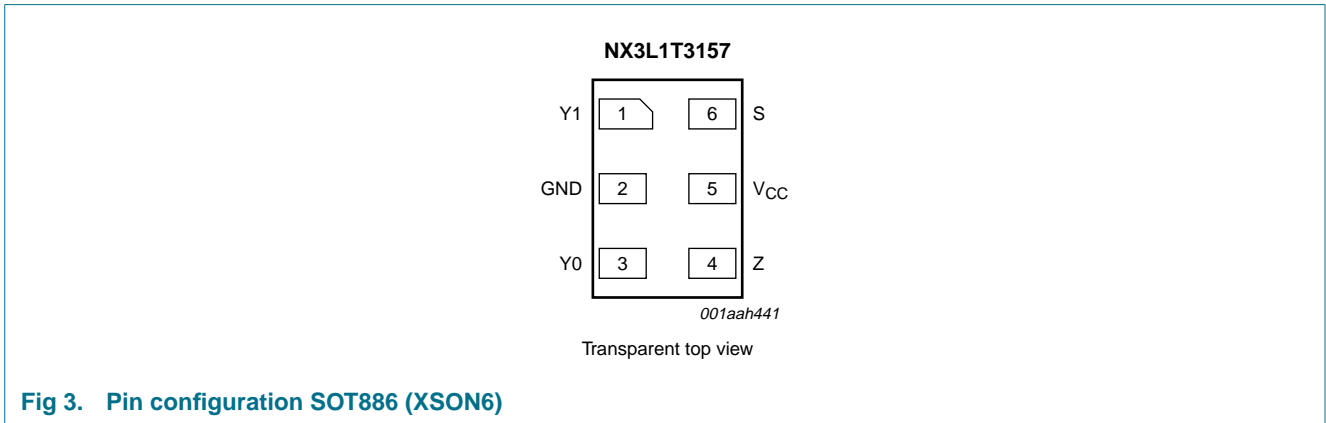

Fig 2. Logic diagram

7. Pinning information

7.1 Pinning



7.2 Pin description

Table 3. Pin description

Symbol	Pin	Description
Y1	1	independent input or output
GND	2	ground (0 V)
Y0	3	independent input or output
Z	4	common output or input
V _{CC}	5	supply voltage
S	6	select input

8. Functional description

Table 4. Function table^[1]

Input S	Channel on
L	Y0
H	Y1

[1] H = HIGH voltage level;
L = LOW voltage level.

9. Limiting values

Table 5. Limiting values

In accordance with the Absolute Maximum Rating System (IEC 60134). Voltages are referenced to GND (ground = 0 V).

Symbol	Parameter	Conditions	Min	Max	Unit
V_{CC}	supply voltage		-0.5	+4.6	V
V_I	input voltage		[1] -0.5	+4.6	V
V_{SW}	switch voltage		[2] -0.5	$V_{CC} + 0.5$	V
I_{IK}	input clamping current	$V_I < -0.5$ V	-50	-	mA
I_{SK}	switch clamping current	$V_I < -0.5$ V or $V_I > V_{CC} + 0.5$ V	-	± 50	mA
I_{SW}	switch current	$V_{SW} > -0.5$ V or $V_{SW} < V_{CC} + 0.5$ V; source or sink current	-	± 350	mA
		$V_{SW} > -0.5$ V or $V_{SW} < V_{CC} + 0.5$ V; pulsed at 1 ms duration, < 10 % duty cycle; peak current	-	± 500	mA
T_{stg}	storage temperature		-65	+150	°C
P_{tot}	total power dissipation	$T_{amb} = -40$ °C to +125 °C	[3] -	250	mW

[1] The minimum input voltage rating may be exceeded if the input current rating is observed.

[2] The minimum and maximum switch voltage ratings may be exceeded if the switch clamping current rating is observed.

[3] For XSON6 packages: above 45 °C the value of P_{tot} derates linearly with 2.4 mW/K.

10. Recommended operating conditions

Table 6. Recommended operating conditions

Symbol	Parameter	Conditions	Min	Typ	Max	Unit
V_{CC}	supply voltage		1.4	-	3.6	V
V_I	input voltage	select input S	0	-	3.6	V
V_{SW}	switch voltage		[1] 0	-	V_{CC}	V
T_{amb}	ambient temperature		-40	-	+125	°C
$\Delta t/\Delta V$	input transition rise and fall rate	$V_{CC} = 1.4$ V to 3.6 V	[2] -	-	200	ns/V

[1] To avoid sinking GND current from terminal Z when switch current flows in terminal Yn, the voltage drop across the bidirectional switch must not exceed 0.4 V. If the switch current flows into terminal Z, no GND current will flow from terminal Yn. In this case, there is no limit for the voltage drop across the switch.

[2] Applies to control signal levels.

11. Static characteristics

Table 7. Static characteristics

At recommended operating conditions; voltages are referenced to GND (ground 0 V).

Symbol	Parameter	Conditions	25 °C			-40 °C to +125 °C			Unit
			Min	Typ	Max	Min	Max (85 °C)	Max (125 °C)	
V _{IH}	HIGH-level input voltage	V _{CC} = 1.4 V to 1.6 V	0.9	-	-	0.9	-	-	V
		V _{CC} = 1.65 V to 1.95 V	0.9	-	-	0.9	-	-	V
		V _{CC} = 2.3 V to 2.7 V	1.1	-	-	1.1	-	-	V
		V _{CC} = 2.7 V to 3.6 V	1.3	-	-	1.3	-	-	V
V _{IL}	LOW-level input voltage	V _{CC} = 1.4 V to 1.6 V	-	-	0.3	-	0.3	0.3	V
		V _{CC} = 1.65 V to 1.95 V	-	-	0.4	-	0.4	0.3	V
		V _{CC} = 2.3 V to 2.7 V	-	-	0.4	-	0.4	0.4	V
		V _{CC} = 2.7 V to 3.6 V	-	-	0.5	-	0.5	0.5	V
I _I	input leakage current	select input S; V _I = GND to 3.6 V; V _{CC} = 1.4 V to 3.6 V	-	-	-	-	±0.5	±1	μA
I _{S(OFF)}	OFF-state leakage current	Y0 and Y1 port; V _{CC} = 1.4 V to 3.6 V; see Figure 4	-	-	±5	-	±50	±500	nA
I _{S(ON)}	ON-state leakage current	Z port; V _{CC} = 1.4 V to 3.6 V; see Figure 5	-	-	±5	-	±50	±500	nA
I _{CC}	supply current	V _I = V _{CC} or GND; V _{CC} = 3.6 V; V _{SW} = GND or V _{CC}	-	-	100	-	690	6000	nA
ΔI _{CC}	additional supply current	V _I = 2.6 V; V _{CC} = 3.6 V; V _{SW} = GND or V _{CC}	-	0.35	0.7	-	1	1	μA
		V _I = 1.8 V; V _{CC} = 3.6 V; V _{SW} = GND or V _{CC}	-	2.5	4	-	5	5	μA
		V _I = 1.8 V; V _{CC} = 2.5 V; V _{SW} = GND or V _{CC}	-	50	200	-	300	500	nA
C _I	input capacitance		-	1.0	-	-	-	-	pF
C _{S(OFF)}	OFF-state capacitance		-	35	-	-	-	-	pF
C _{S(ON)}	ON-state capacitance		-	130	-	-	-	-	pF

11.1 Test circuits

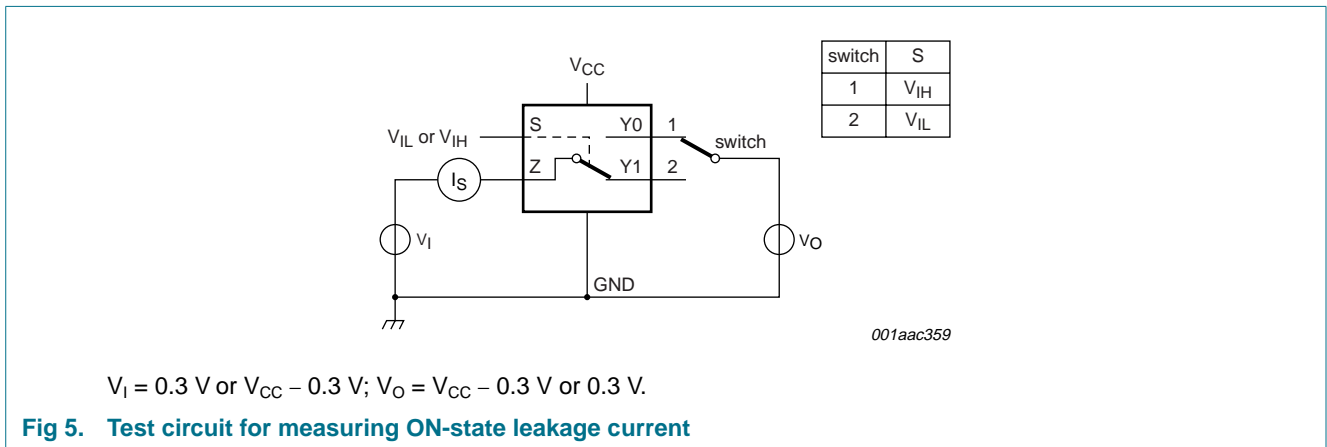
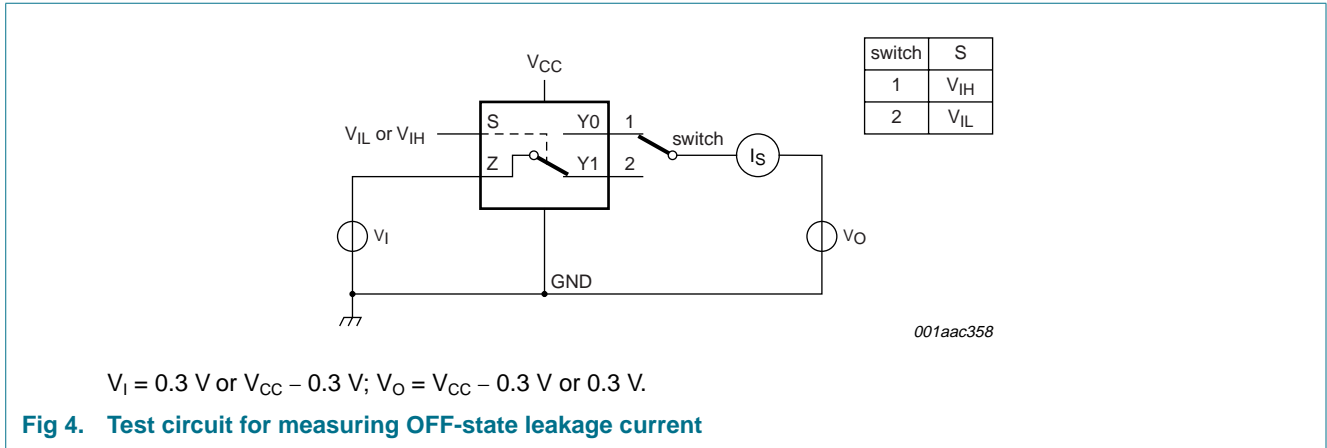

11.2 ON resistance

Table 8. ON resistance

At recommended operating conditions; voltages are referenced to GND (ground = 0 V); for graphs see [Figure 7](#) to [Figure 12](#).

Symbol	Parameter	Conditions	-40 °C to +85 °C			-40 °C to +125 °C		Unit
			Min	Typ ^[1]	Max	Min	Max	
$R_{ON(peak)}$	ON resistance (peak)	$V_I = \text{GND to } V_{CC};$ $I_{SW} = 100\text{ mA};$ see Figure 6						
		$V_{CC} = 1.4\text{ V}$	-	1.6	3.7	-	4.1	Ω
		$V_{CC} = 1.65\text{ V}$	-	1.0	1.6	-	1.7	Ω
		$V_{CC} = 2.3\text{ V}$	-	0.55	0.8	-	0.9	Ω
		$V_{CC} = 2.7\text{ V}$	-	0.5	0.75	-	0.9	Ω

Table 8. ON resistance ...continued

At recommended operating conditions; voltages are referenced to GND (ground = 0 V); for graphs see [Figure 7](#) to [Figure 12](#).

Symbol	Parameter	Conditions	-40 °C to +85 °C			-40 °C to +125 °C		Unit	
			Min	Typ ^[1]	Max	Min	Max		
ΔR_{ON}	ON resistance mismatch between channels	$V_I = \text{GND to } V_{CC};$ $I_{SW} = 100 \text{ mA}$	^[2]						
			$V_{CC} = 1.4 \text{ V}$	-	0.04	0.3	-	0.3	Ω
			$V_{CC} = 1.65 \text{ V}$	-	0.04	0.2	-	0.3	Ω
			$V_{CC} = 2.3 \text{ V}$	-	0.02	0.08	-	0.1	Ω
		$V_{CC} = 2.7 \text{ V}$	-	0.02	0.075	-	0.1	Ω	
$R_{ON(\text{flat})}$	ON resistance (flatness)	$V_I = \text{GND to } V_{CC};$ $I_{SW} = 100 \text{ mA}$	^[3]						
			$V_{CC} = 1.4 \text{ V}$	-	1.0	3.3	-	3.6	Ω
			$V_{CC} = 1.65 \text{ V}$	-	0.5	1.2	-	1.3	Ω
			$V_{CC} = 2.3 \text{ V}$	-	0.15	0.3	-	0.35	Ω
		$V_{CC} = 2.7 \text{ V}$	-	0.13	0.3	-	0.35	Ω	

[1] Typical values are measured at $T_{\text{amb}} = 25 \text{ }^\circ\text{C}$.

[2] Measured at identical V_{CC} , temperature and input voltage.

[3] Flatness is defined as the difference between the maximum and minimum value of ON resistance measured at identical V_{CC} and temperature.

11.3 ON resistance test circuit and graphs

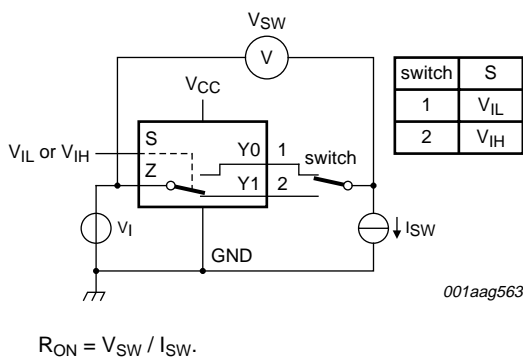
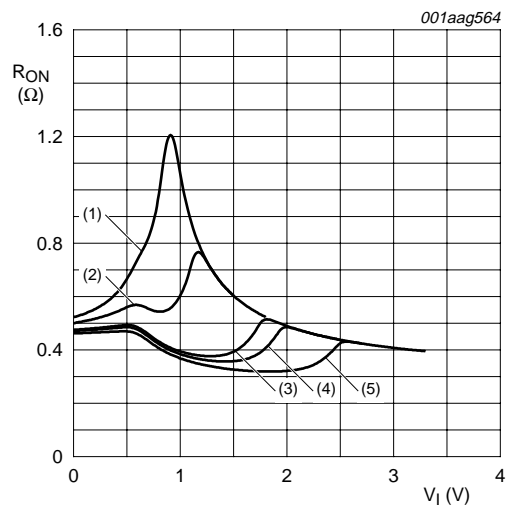

Fig 6. Test circuit for measuring ON resistance



- (1) $V_{CC} = 1.5 \text{ V}$.
- (2) $V_{CC} = 1.8 \text{ V}$.
- (3) $V_{CC} = 2.5 \text{ V}$.
- (4) $V_{CC} = 2.7 \text{ V}$.
- (5) $V_{CC} = 3.3 \text{ V}$.

Measured at $T_{\text{amb}} = 25 \text{ }^\circ\text{C}$.

Fig 7. Typical ON resistance as a function of input voltage

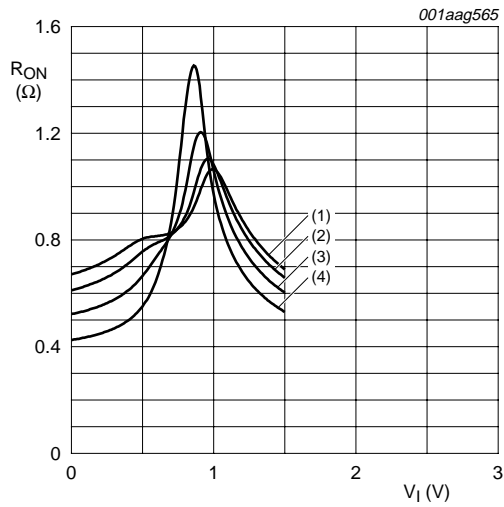

- (1) $T_{amb} = 125\text{ }^{\circ}\text{C}$.
- (2) $T_{amb} = 85\text{ }^{\circ}\text{C}$.
- (3) $T_{amb} = 25\text{ }^{\circ}\text{C}$.
- (4) $T_{amb} = -40\text{ }^{\circ}\text{C}$.

Fig 8. ON resistance as a function of input voltage;
 $V_{CC} = 1.5\text{ V}$

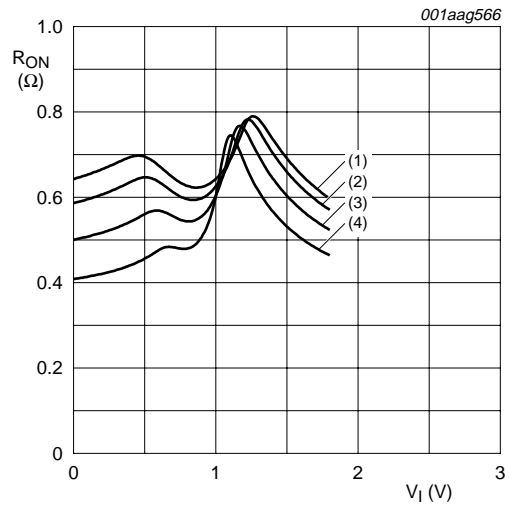

- (1) $T_{amb} = 125\text{ }^{\circ}\text{C}$.
- (2) $T_{amb} = 85\text{ }^{\circ}\text{C}$.
- (3) $T_{amb} = 25\text{ }^{\circ}\text{C}$.
- (4) $T_{amb} = -40\text{ }^{\circ}\text{C}$.

Fig 9. ON resistance as a function of input voltage;
 $V_{CC} = 1.8\text{ V}$

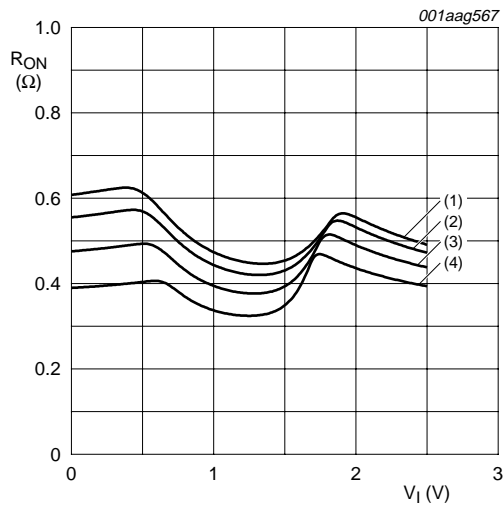

- (1) $T_{amb} = 125\text{ }^{\circ}\text{C}$.
- (2) $T_{amb} = 85\text{ }^{\circ}\text{C}$.
- (3) $T_{amb} = 25\text{ }^{\circ}\text{C}$.
- (4) $T_{amb} = -40\text{ }^{\circ}\text{C}$.

Fig 10. ON resistance as a function of input voltage;
 $V_{CC} = 2.5\text{ V}$

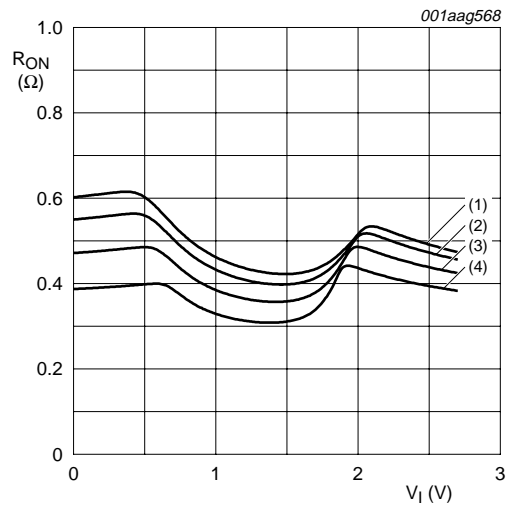

- (1) $T_{amb} = 125\text{ }^{\circ}\text{C}$.
- (2) $T_{amb} = 85\text{ }^{\circ}\text{C}$.
- (3) $T_{amb} = 25\text{ }^{\circ}\text{C}$.
- (4) $T_{amb} = -40\text{ }^{\circ}\text{C}$.

Fig 11. ON resistance as a function of input voltage;
 $V_{CC} = 2.7\text{ V}$

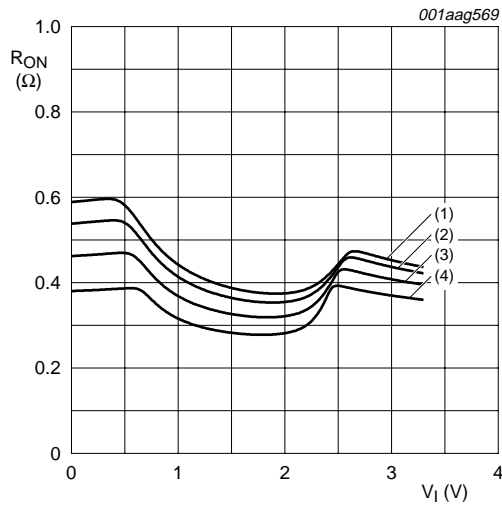

- (1) $T_{amb} = 125\text{ °C}$.
- (2) $T_{amb} = 85\text{ °C}$.
- (3) $T_{amb} = 25\text{ °C}$.
- (4) $T_{amb} = -40\text{ °C}$.

Fig 12. ON resistance as a function of input voltage; $V_{CC} = 3.3\text{ V}$

12. Dynamic characteristics

Table 9. Dynamic characteristics

At recommended operating conditions; voltages are referenced to GND (ground = 0 V); for load circuit see Figure 15.

Symbol	Parameter	Conditions	25 °C			-40 °C to +125 °C			Unit
			Min	Typ ^[1]	Max	Min	Max (85 °C)	Max (125 °C)	
t_{en}	enable time	S to Z or Yn; see Figure 13							
		$V_{CC} = 1.4\text{ V to }1.6\text{ V}$	-	50	90	-	120	120	ns
		$V_{CC} = 1.65\text{ V to }1.95\text{ V}$	-	36	70	-	80	90	ns
		$V_{CC} = 2.3\text{ V to }2.7\text{ V}$	-	24	45	-	50	55	ns
		$V_{CC} = 2.7\text{ V to }3.6\text{ V}$	-	22	40	-	45	50	ns
t_{dis}	disable time	S to Z or Yn; see Figure 13							
		$V_{CC} = 1.4\text{ V to }1.6\text{ V}$	-	32	70	-	80	90	ns
		$V_{CC} = 1.65\text{ V to }1.95\text{ V}$	-	20	55	-	60	65	ns
		$V_{CC} = 2.3\text{ V to }2.7\text{ V}$	-	12	25	-	30	35	ns
		$V_{CC} = 2.7\text{ V to }3.6\text{ V}$	-	10	20	-	25	30	ns

Table 9. Dynamic characteristics ...continued

At recommended operating conditions; voltages are referenced to GND (ground = 0 V); for load circuit see [Figure 15](#).

Symbol	Parameter	Conditions	25 °C			-40 °C to +125 °C			Unit
			Min	Typ ^[1]	Max	Min	Max (85 °C)	Max (125 °C)	
t_{b-m}	break-before-make time	see Figure 14 ^[2]							
		$V_{CC} = 1.4 \text{ V to } 1.6 \text{ V}$	-	19	-	9	-	-	ns
		$V_{CC} = 1.65 \text{ V to } 1.95 \text{ V}$	-	17	-	7	-	-	ns
		$V_{CC} = 2.3 \text{ V to } 2.7 \text{ V}$	-	13	-	4	-	-	ns
		$V_{CC} = 2.7 \text{ V to } 3.6 \text{ V}$	-	10	-	3	-	-	ns

[1] Typical values are measured at $T_{amb} = 25 \text{ °C}$ and $V_{CC} = 1.5 \text{ V}, 1.8 \text{ V}, 2.5 \text{ V}$ and 3.3 V respectively.

[2] Break-before-make guaranteed by design.

12.1 Waveform and test circuits

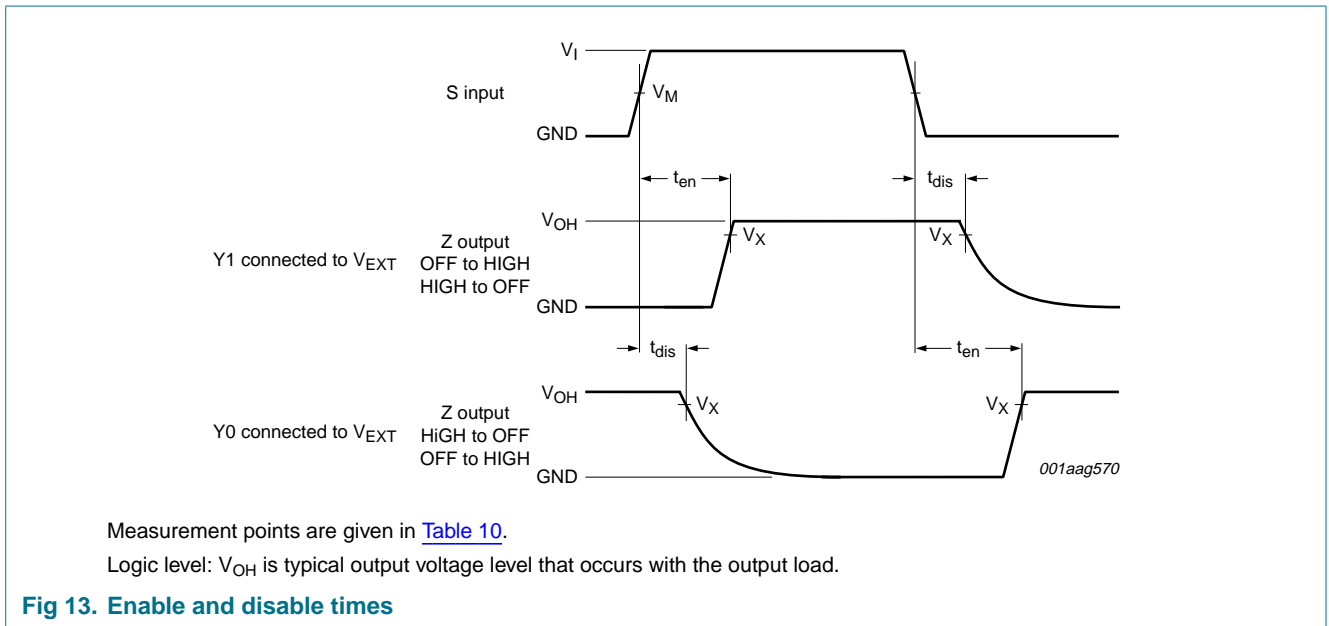
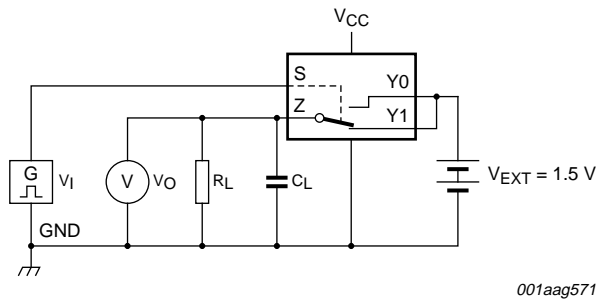
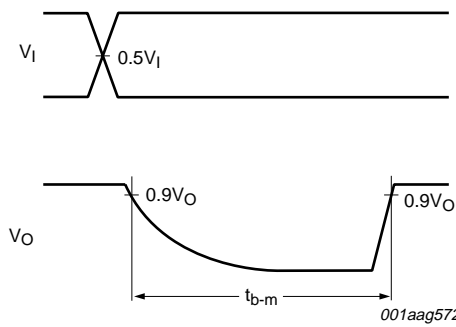

Table 10. Measurement points

Supply voltage	Input	Output
V_{CC}	V_M	V_X
1.4 V to 3.6 V	$0.5V_{CC}$	$0.9V_{OH}$



a. Test circuit.



b. Input and output measurement points

Fig 14. Test circuit for measuring break-before-make timing

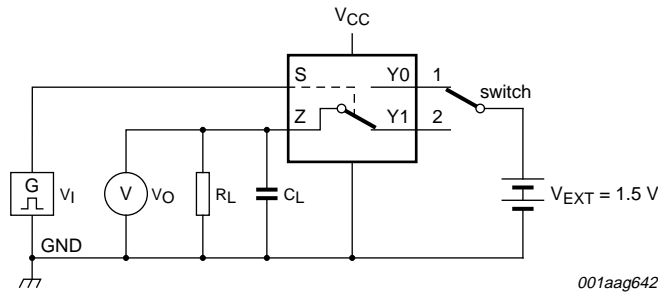

Test data is given in [Table 11](#).

Definitions test circuit:

R_L = Load resistance.

C_L = Load capacitance including jig and probe capacitance.

V_{EXT} = External voltage for measuring switching times.

Fig 15. Load circuit for switching times

Table 11. Test data

Supply voltage	Input		Load	
V_{CC}	V_I	t_r, t_f	C_L	R_L
1.4 V to 3.6 V	V_{CC}	≤ 2.5 ns	35 pF	50 Ω

12.2 Additional dynamic characteristics

Table 12. Additional dynamic characteristics

At recommended operating conditions; voltages are referenced to GND (ground = 0 V); $V_I = \text{GND}$ or V_{CC} (unless otherwise specified); $t_r = t_f \leq 2.5 \text{ ns}$.

Symbol	Parameter	Conditions	25 °C			Unit
			Min	Typ	Max	
THD	total harmonic distortion	$f_i = 20 \text{ Hz to } 20 \text{ kHz}; R_L = 32 \text{ } \Omega$; see Figure 16 [1]				
		$V_{CC} = 1.4 \text{ V}; V_I = 1 \text{ V (p-p)}$	-	0.15	-	%
		$V_{CC} = 1.65 \text{ V}; V_I = 1.2 \text{ V (p-p)}$	-	0.10	-	%
		$V_{CC} = 2.3 \text{ V}; V_I = 1.5 \text{ V (p-p)}$	-	0.015	-	%
		$V_{CC} = 2.7 \text{ V}; V_I = 2 \text{ V (p-p)}$	-	0.024	-	%
$f_{(-3\text{dB})}$	-3 dB frequency response	$R_L = 50 \text{ } \Omega$; see Figure 17 [1]				
		$V_{CC} = 1.4 \text{ V to } 3.6 \text{ V}$	-	60	-	MHz
α_{iso}	isolation (OFF-state)	$f_i = 100 \text{ kHz}; R_L = 50 \text{ } \Omega$; see Figure 18 [1]				
		$V_{CC} = 1.4 \text{ V to } 3.6 \text{ V}$	-	-90	-	dB
V_{ct}	crosstalk voltage	between digital inputs and switch; $f_i = 1 \text{ MHz}; C_L = 50 \text{ pF}; R_L = 50 \text{ } \Omega$; see Figure 19				
		$V_{CC} = 1.4 \text{ V to } 3.6 \text{ V}$	-	0.21	-	V
Q_{inj}	charge injection	$f_i = 1 \text{ MHz}; C_L = 0.1 \text{ nF}; R_L = 1 \text{ M}\Omega; V_{\text{gen}} = 0 \text{ V}; R_{\text{gen}} = 0 \text{ } \Omega$; see Figure 20				
		$V_{CC} = 1.5 \text{ V}$	-	3	-	pC
		$V_{CC} = 1.8 \text{ V}$	-	4	-	pC
		$V_{CC} = 2.5 \text{ V}$	-	6	-	pC
		$V_{CC} = 3.3 \text{ V}$	-	9	-	pC

[1] f_i is biased at $0.5V_{CC}$.

12.3 Test circuits

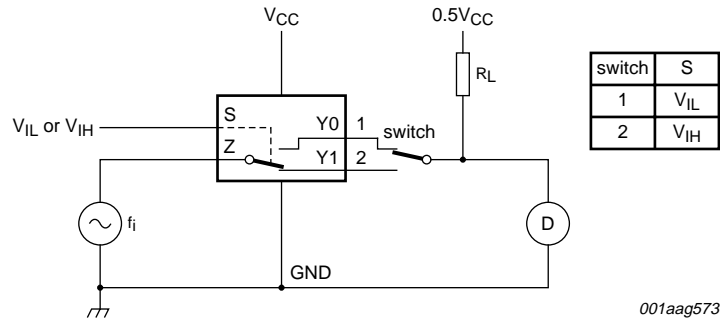
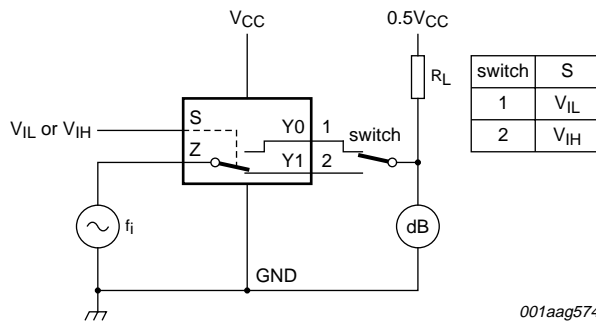
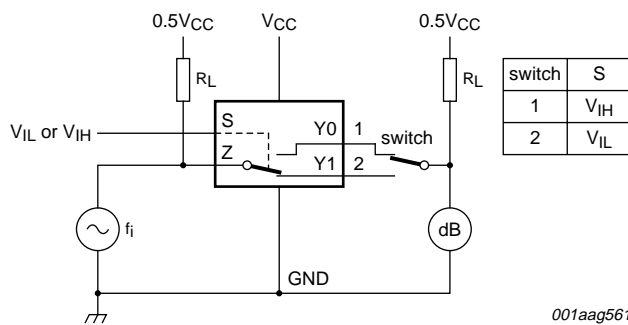

Fig 16. Test circuit for measuring total harmonic distortion



Adjust f_i voltage to obtain 0 dBm level at output. Increase f_i frequency until dB meter reads -3 dB.

Fig 17. Test circuit for measuring the frequency response when channel is in ON-state



Adjust f_i voltage to obtain 0 dBm level at input.

Fig 18. Test circuit for measuring isolation (OFF-state)

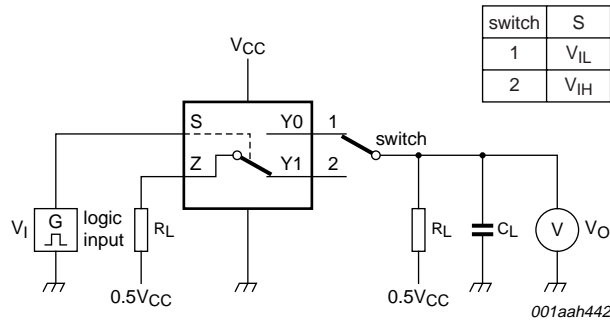

a. Test circuit

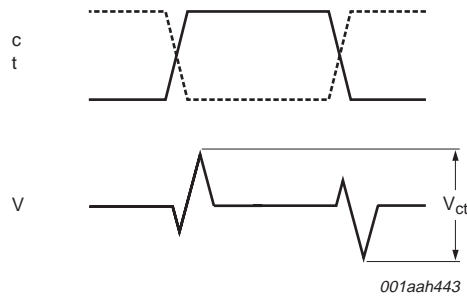

b. Input and output pulse definitions

Fig 19. Test circuit for measuring crosstalk voltage between digital inputs and switch

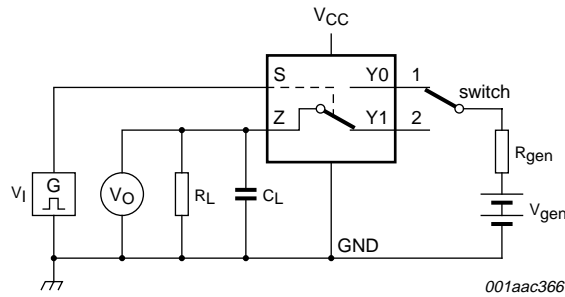

a. Test circuit.

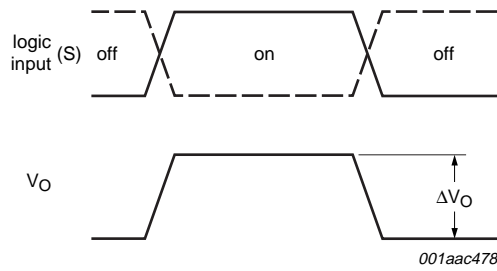

b. Input and output pulse definitions.

Definition: $Q_{inj} = \Delta V_O \times C_L$.

ΔV_O = output voltage variation.

R_{gen} = generator resistance.

V_{gen} = generator voltage.

Fig 20. Test circuit for measuring charge injection

13. Package outline

XSON6: plastic extremely thin small outline package; no leads; 6 terminals; body 1 x 1.45 x 0.5 mm

SOT886

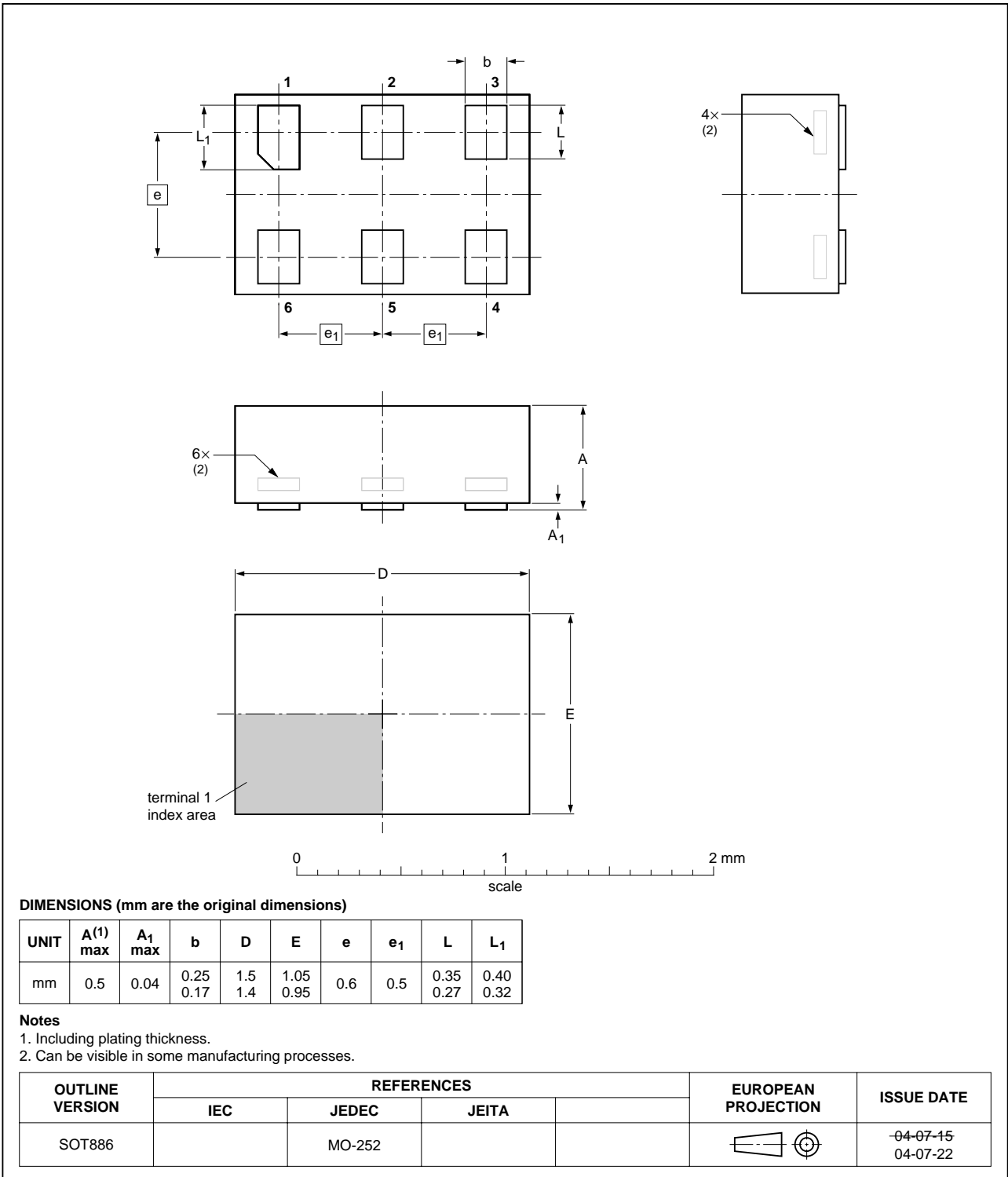

Fig 21. Package outline SOT886 (XSON6)

14. Abbreviations

Table 13. Abbreviations

Acronym	Description
CDM	Charged Device Model
CMOS	Complementary Metal Oxide Semiconductor
DUT	Device Under Test
ESD	ElectroStatic Discharge
HBM	Human Body Model
MM	Machine Model
TTL	Transistor-Transistor Logic

15. Revision history

Table 14. Revision history

Document ID	Release date	Data sheet status	Change notice	Supersedes
NX3L1T3157_1	20080103	Product data sheet	-	-

16. Legal information

16.1 Data sheet status

Document status ^{[1][2]}	Product status ^[3]	Definition
Objective [short] data sheet	Development	This document contains data from the objective specification for product development.
Preliminary [short] data sheet	Qualification	This document contains data from the preliminary specification.
Product [short] data sheet	Production	This document contains the product specification.

[1] Please consult the most recently issued document before initiating or completing a design.

[2] The term 'short data sheet' is explained in section "Definitions".

[3] The product status of device(s) described in this document may have changed since this document was published and may differ in case of multiple devices. The latest product status information is available on the Internet at URL <http://www.nxp.com>.

16.2 Definitions

Draft — The document is a draft version only. The content is still under internal review and subject to formal approval, which may result in modifications or additions. NXP Semiconductors does not give any representations or warranties as to the accuracy or completeness of information included herein and shall have no liability for the consequences of use of such information.

Short data sheet — A short data sheet is an extract from a full data sheet with the same product type number(s) and title. A short data sheet is intended for quick reference only and should not be relied upon to contain detailed and full information. For detailed and full information see the relevant full data sheet, which is available on request via the local NXP Semiconductors sales office. In case of any inconsistency or conflict with the short data sheet, the full data sheet shall prevail.

16.3 Disclaimers

General — Information in this document is believed to be accurate and reliable. However, NXP Semiconductors does not give any representations or warranties, expressed or implied, as to the accuracy or completeness of such information and shall have no liability for the consequences of use of such information.

Right to make changes — NXP Semiconductors reserves the right to make changes to information published in this document, including without limitation specifications and product descriptions, at any time and without notice. This document supersedes and replaces all information supplied prior to the publication hereof.

Suitability for use — NXP Semiconductors products are not designed, authorized or warranted to be suitable for use in medical, military, aircraft, space or life support equipment, nor in applications where failure or

malfunction of an NXP Semiconductors product can reasonably be expected to result in personal injury, death or severe property or environmental damage. NXP Semiconductors accepts no liability for inclusion and/or use of NXP Semiconductors products in such equipment or applications and therefore such inclusion and/or use is at the customer's own risk.

Applications — Applications that are described herein for any of these products are for illustrative purposes only. NXP Semiconductors makes no representation or warranty that such applications will be suitable for the specified use without further testing or modification.

Limiting values — Stress above one or more limiting values (as defined in the Absolute Maximum Ratings System of IEC 60134) may cause permanent damage to the device. Limiting values are stress ratings only and operation of the device at these or any other conditions above those given in the Characteristics sections of this document is not implied. Exposure to limiting values for extended periods may affect device reliability.

Terms and conditions of sale — NXP Semiconductors products are sold subject to the general terms and conditions of commercial sale, as published at <http://www.nxp.com/profile/terms>, including those pertaining to warranty, intellectual property rights infringement and limitation of liability, unless explicitly otherwise agreed to in writing by NXP Semiconductors. In case of any inconsistency or conflict between information in this document and such terms and conditions, the latter will prevail.

No offer to sell or license — Nothing in this document may be interpreted or construed as an offer to sell products that is open for acceptance or the grant, conveyance or implication of any license under any copyrights, patents or other industrial or intellectual property rights.

16.4 Trademarks

Notice: All referenced brands, product names, service names and trademarks are the property of their respective owners.

17. Contact information

For additional information, please visit: <http://www.nxp.com>

For sales office addresses, send an email to: salesaddresses@nxp.com

18. Contents

1	General description	1
2	Features	1
3	Applications	2
4	Ordering information	2
5	Marking	2
6	Functional diagram	2
7	Pinning information	3
7.1	Pinning	3
7.2	Pin description	3
8	Functional description	3
9	Limiting values	4
10	Recommended operating conditions	4
11	Static characteristics	5
11.1	Test circuits	6
11.2	ON resistance	6
11.3	ON resistance test circuit and graphs	7
12	Dynamic characteristics	9
12.1	Waveform and test circuits	10
12.2	Additional dynamic characteristics	12
12.3	Test circuits	13
13	Package outline	16
14	Abbreviations	17
15	Revision history	17
16	Legal information	18
16.1	Data sheet status	18
16.2	Definitions	18
16.3	Disclaimers	18
16.4	Trademarks	18
17	Contact information	18
18	Contents	19

Please be aware that important notices concerning this document and the product(s) described herein, have been included in section 'Legal information'.



© NXP B.V. 2008.

All rights reserved.

For more information, please visit: <http://www.nxp.com>

For sales office addresses, please send an email to: salesaddresses@nxp.com

Date of release: 3 January 2008

Document identifier: NX3L1T3157_1