

Preliminary TOSHIBA Bi-CMOS Integrated Circuit Silicon Monolithic

TB6561NG

Dual Full-Bridge Driver IC

The TB6561NG is a dual bridge driver IC for DC brush motor that contains MOS transistors in an output stage.

By using low ON-resistance MOS transistors and PWM current control circuitry, the driver achieves high efficiency.

Features

- Power supply voltage: 40 V (max)
- Output current: 1.5 A (max)
- Low ON-resistance: 1.5 Ω (upper and lower transistors/typ.)
- Direct PWM current control system
- Power-saving function
- Forward/reverse/short brake/stop modes
- Over-current protection: $I_{lim} = 2.5A$ (typ.)
- Thermal shutdown
- Package: SDIP-24-P-300-1.78

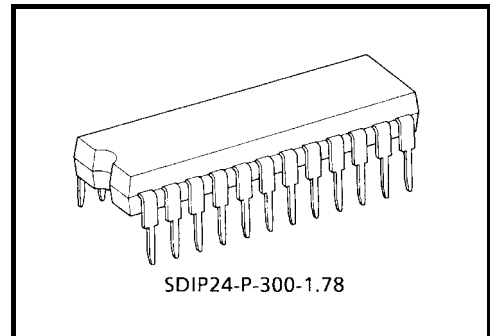

SDIP24-P-300-1.78

Weight: 1.62 g (typ.)

The TB6561NG is a Pb-free product.

The following conditions apply to solderability:

*Solderability

1. Use of Sn-37Pb solder bath
 - *solder bath temperature = 230°C
 - *dipping time = 5 seconds
 - *number of times = once
 - *use of R-type flux
2. Use of Sn-3.0Ag-0.5Cu solder bath
 - *solder bath temperature = 245°C
 - *dipping time = 5 seconds
 - *number of times = once
 - *use of R-type flux

Block Diagram

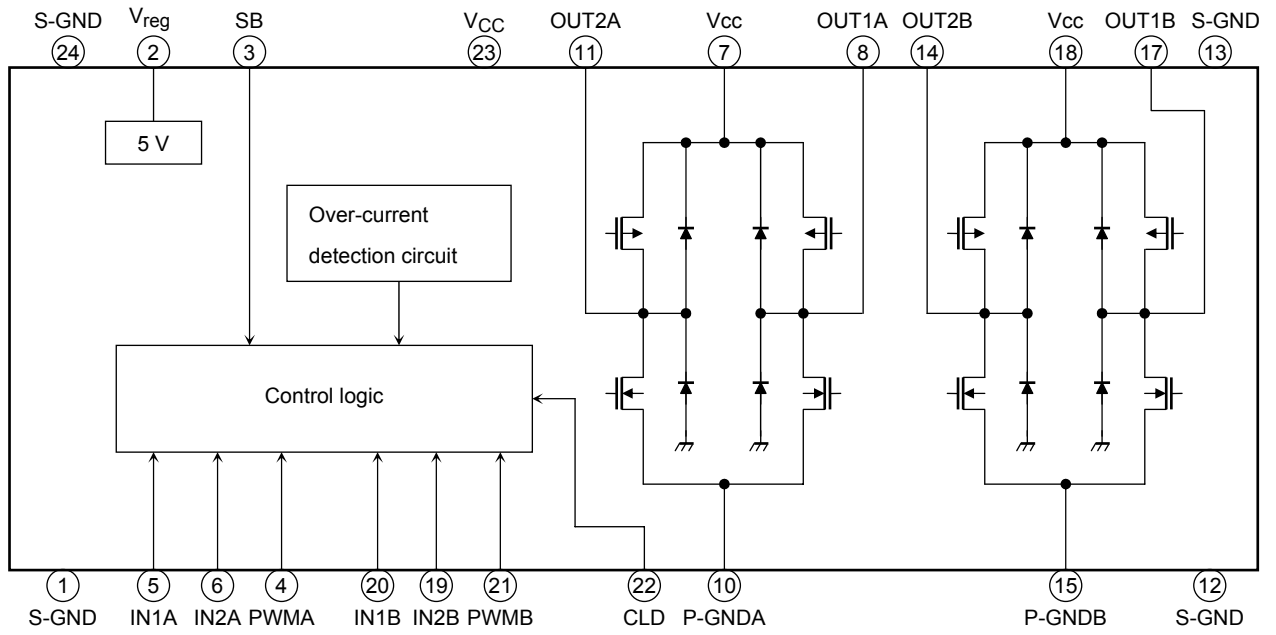

N.C.: 9pin, 16pin

Absolute Maximum Ratings (Ta = 25°C)

Characteristics	Symbol	Rating	Unit
Power supply voltage	V _{CC}	40	V
Output voltage	V _O	40 (Note 1)	V
Output current	I _O (Peak)	1.5	A
Power dissipation	P _D	2.5 (Note 2)	W
Operating temperature	T _{opr}	-20 to 85	°C
Storage temperature	T _{stg}	-55 to 150	°C

Note 1: Please use output voltage within the above absolute maximum rating, 40 V, in which includes back-EMF voltage.

Note 2: When mounted on a board (50 mm × 50 mm × 1.6 mm, Cu area: 50%)

Operating Range (Ta = 25°C)

Characteristics	Symbol	Rating	Unit
Power supply voltage	V _{CC} , V _M	10 to 36	V

Pin Description

Pin No.	Symbol	Function Description	Remarks
1	S-GND	Signal ground	—
2	V _{reg}	5-V output pin	Connect a capacitor (0.1 μ F) between this pin and S-GND pin.
3	SB	Standby pin	High: Start, Low: Standby
4	PWMA	Rotation direction control pin (chA)	Apply a 0-V/5-V signal.
5	IN1A	Input pin 1 (chA)	Apply a 0-V/5-V signal.
6	IN1 B	Input pin 2 (chA)	Apply a 0-V/5-V signal.
7	V _{cc}	Power supply voltage input pin for motor drive (chA)	V _{MA} (opr) = 10 V to 36 V
8	OUT1A	Output pin 1 (chA)	Connect to a motor coil pin.
9	N.C.	—	—
10	P-GND	Power ground for chA output	—
11	OUT2 A	Output pin 2 (chA)	Connect to a motor coil pin.
12	S-GND	Signal ground	—
13	S-GND	Signal ground	—
14	OUT2B	Output pin 2 (chB)	Connect to a motor coil pin.
15	P-GND	Power ground	—
16	N.C.	—	—
17	OUT1 B	Output pin 1 (chB)	Connect to a motor coil pin.
18	V _{cc}	Power supply voltage input pin for motor drive (chB)	V _{MB} (opr) = 10 V to 36 V
19	IN2B	Input pin used to set output current level (chB)	Input 0-V/5-V signal.
20	IN1B	Input pin used to set output current level (chB)	Input 0-V/5-V signal.
21	PWM B	Rotation direction control pin (chB)	Input 0-V/5-V signal.
22	CLD	Output signal pin of current limiter detection	—
23	V _{CC}	Power supply voltage input pin	V _{CC} (opr) = 10 V to 36 V
24	S-GND	Signal ground	—

Electrical Characteristics ($V_{CC} = V_{MA} = V_{MB} = 24\text{ V}$, $T_a = 25^\circ\text{C}$)

Characteristics		Symbol	Test Circuit	Test Condition	Min	Typ.	Max	Unit
Supply current		I_{CC1}	—	Stop mode	—	5.5	10	mA
		I_{CC2}		Forward/reverse mode	—	5.0	9	
		I_{CC3}		Short break mode	—	5.5	10	
		I_{CC4}		Standby mode	—	1.5	3	
Control circuit	Input voltage	V_{INH}	—	—	2.3	—	5.5	V
		V_{INL}		—	-0.2	—	0.8	
	Hysteresis voltage	$V_{IN (HYS)}$	—	(Design guarantee)	—	0.4	—	
	Input current	I_{INH}	—	$V_{IN} = 5\text{ V}$	30	50	75	μA
I_{INL}		$V_{IN} = 0\text{ V}$		—	—	5		
PWM input circuit	Input voltage	V_{PWMH}	—	—	2.3	—	5.5	V
		V_{PWML}		—	-0.2	—	0.8	
	Hysteresis voltage	$V_{PWM (HYS)}$	—	(Design guarantee)	—	0.4	—	
	Input current	I_{PWMH}	—	$V_{PWM} = 5\text{ V}$	30	50	75	μA
		I_{PWML}		$V_{PWM} = 0\text{ V}$	—	—	5	
	PWM frequency	f_{PWM}	—	Duty: 50 %	—	—	100	kHz
Minimum clock pulse width	$t_w(\text{PWM})$	—	—	2.0	—	—	μs	
Standby circuit	Input voltage	V_{INSH}	—	—	2.3	—	5.5	V
		V_{INSL}		—	-0.2	—	0.8	
	Hysteresis voltage	$V_{IN (HYS)}$	—	(Design guarantee)	—	0.4	—	
	Input current	I_{INSH}	—	$V_{IN} = 5\text{ V}$	30	50	75	μA
I_{INSL}		$V_{IN} = 0\text{ V}$		—	—	5		
Output ON resistance		$R_{ON (U + L)}$	—	$I_o = 0.2\text{ A}$	—	1.5	2.0	Ω
				$I_o = 1.5\text{ A}$	—	1.5	2.0	
Output leakage current		$I_L (U)$	—	$V_{CC} = 40\text{ V}$	—	—	10	μA
		$I_L (L)$		$V_{CC} = 40\text{ V}$	—	—	10	
Diode forward voltage		$V_F (U)$	—	$I_o = 1.5\text{ A}$	—	1.3	2.0	V
		$V_F (L)$		$I_o = 1.5\text{ A}$	—	1.3	2.0	
Internal reference voltage		V_{reg}	—	$I_{reg} = 1\text{ mA}$	4.75	5	5.25	V
Output signal of current limiter detection		V_{CLDH}	—	$I_o = 50\text{ }\mu\text{A}$	4.25	—	V_{reg}	V
		V_{CLDL}				—	0.5	
Offset time for current limiter		$I_{SD (OFF)}$	—	(Design guarantee)	—	50	—	μs
Thermal shutdown circuit operating temperature		T_{SD}	—	(Design guarantee)	—	160	—	$^\circ\text{C}$

Component Description

1. Control Input/PWM Input Circuit

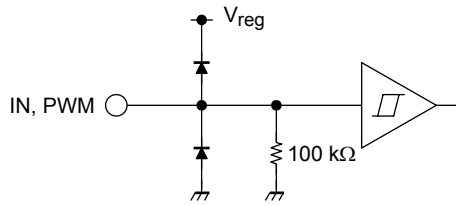

- The input signals are shown below. Input at the CMOS and TTL levels can be provided. Note that the input signals have a hysteresis of 0.2 V (typ.).
 V_{INH}/V_{PWMH} : 2 to 5.5 V
 V_{INL}/V_{PWML} : GND to 0.8 V
- The PWM input frequency should be 100 kHz or less.

Input/Output Function

Input				Output		
IN1	IN2	SB	PWM	OUT1	OUT2	Mode
H	H	H	H	L	L	Short brake
			L			
L	H	H	H	L	H	CW/CCW
			L	L	L	Short brake
H	L	H	H	H	L	CCW/CW
			L	L	L	Short brake
L	L	H	H	OFF (high-impedance)		Stop
			L			
H/L	H/L	L	H	OFF (high-impedance)		Standby
			L			

- PWM control function
 The IC enters CW (CCW) mode and short brake mode alternately in PWM current control. To prevent shoot-through current caused by simultaneous conduction of upper and lower transistors in the output stage, a dead time is internally generated for 300 ns (target spec) when switching the upper and lower transistors. Therefore, synchronous rectification for high efficiency in PWM current control can be achieved without an off-time that is generated via an external input. Even when toggling between CW and CCW modes, and CW (CCW) and short brake modes, the off-time is not required due to the internally generated dead time.

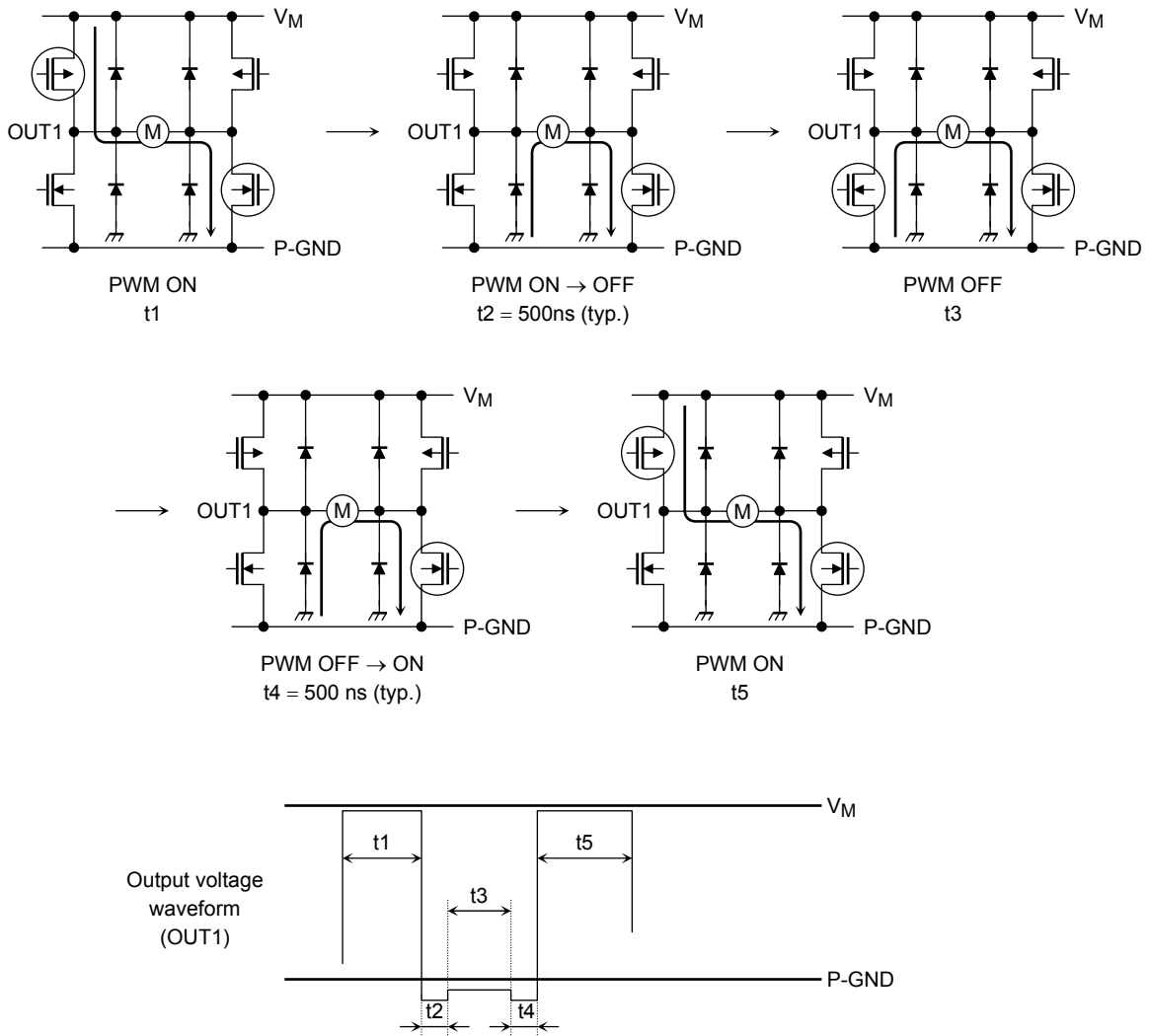

2. Thermal Shutdown Circuit (TSD)

The IC incorporates a thermal shutdown circuit. When the junction temperature (T_j) reaches 160°C (typ.), the output transistors are turned off.

After $50\ \mu\text{s}$ (typ.), the output transistors are turned on automatically.

The IC has 20°C of temperature hysteresis.

$T_{SD} = 160^\circ\text{C}$ (target spec)

$\Delta T_{SD} = 20^\circ\text{C}$ (target spec)

3. Overcurrent Protection Circuit (ISD)

The IC incorporates an overcurrent protection circuit to detect voltage that flows through the output transistors. The overcurrent threshold is 2.5 A (typ.).

Currents that flow through the output transistors are monitored individually. If overcurrent is detected in at least one of the transistors, all transistors are turned off.

The IC incorporates a timer to count 50 μ s (typ.) for which the transistors are off. After 50 μ s, they are turned on automatically. If an overcurrent occurs again, the same operation is repeated. To prevent false detection due to glitch, the circuit turns off the transistors only when current that exceeds the overcurrent threshold flows for 10 μ s or longer.

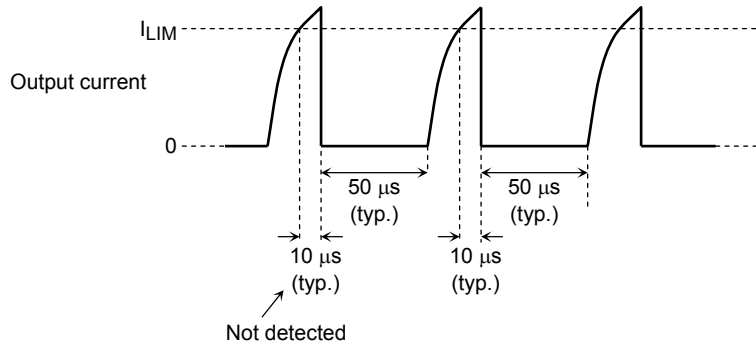

The over-current threshold is a target spec. It varies in a range from approximately 1.5 A to 3.5 A.

4. Current Limiter Detection Circuit (CLD)

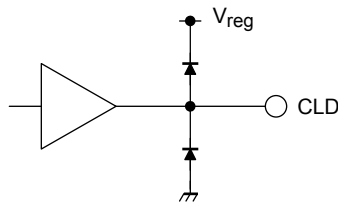

The CLD pin outputs the states of the current limiter and thermal shutdown circuits. If the current limiter for either channel A or B or the thermal shutdown circuit (shared for both channels) operates, the CLD pin state changes from low (normal state) to high.

The CLD circuit supports automatic recovery; its output returns to low once the current decreases to a value below the limit or once the thermal shutdown state is released.

Mode	CLD Output
Under TSD operation and current detection	H
Normal	L

< When current limiter operated >

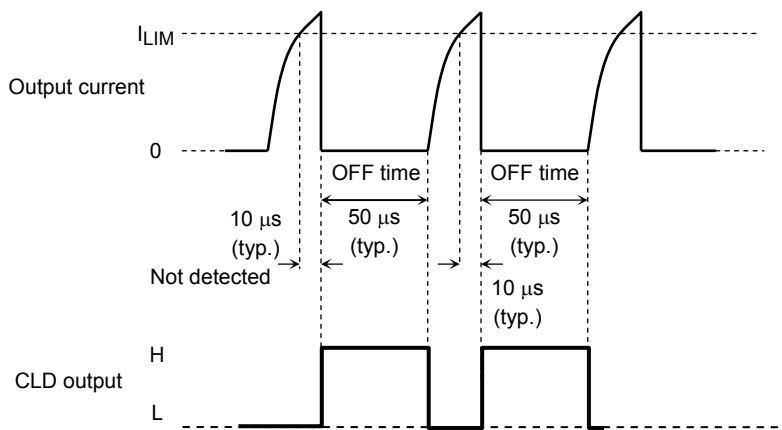

< When TSD circuit operated >

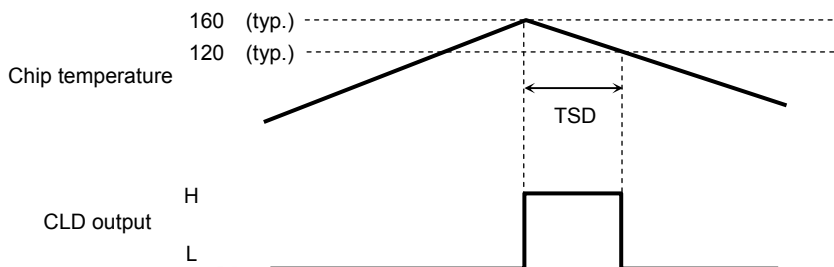

Current noise and other factors may cause false pulse output. To avoid this, Toshiba recommends a user to insert a filter or to carry out detection using a sampling monitor. When inserting a filter, please set the filter time-constant, considering the 50-μs CLD output.

$P_D - T_a$

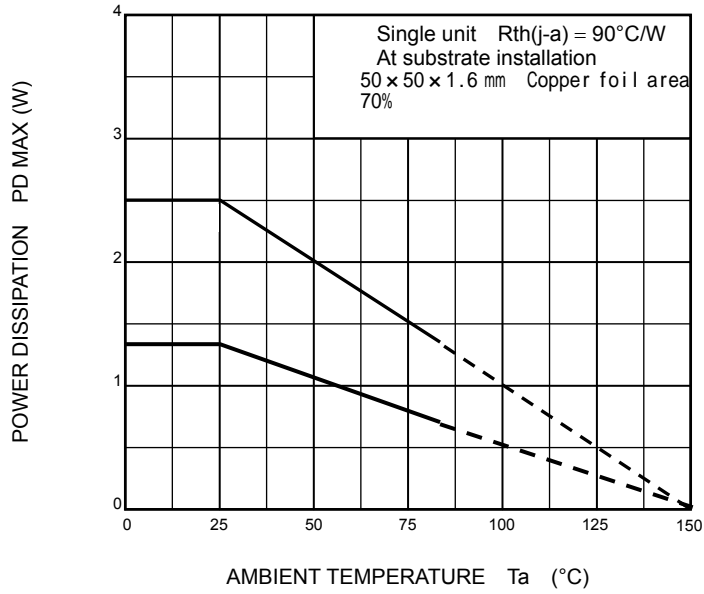

OUTPUT UPPER SIDE $I_{out} - V_{CE(sat)}$ <Reference data>

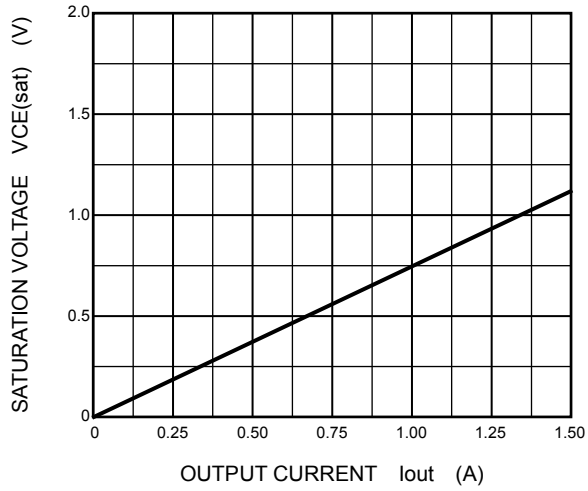

OUTPUT LOWER SIDE $I_{out} - V_{CE(sat)}$ <Reference data>

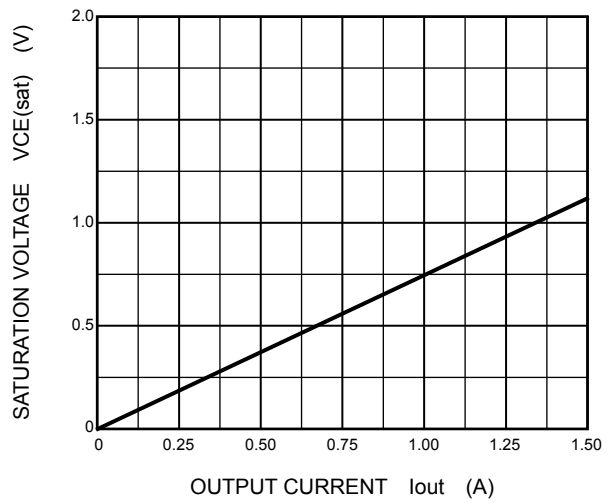

Application Circuit

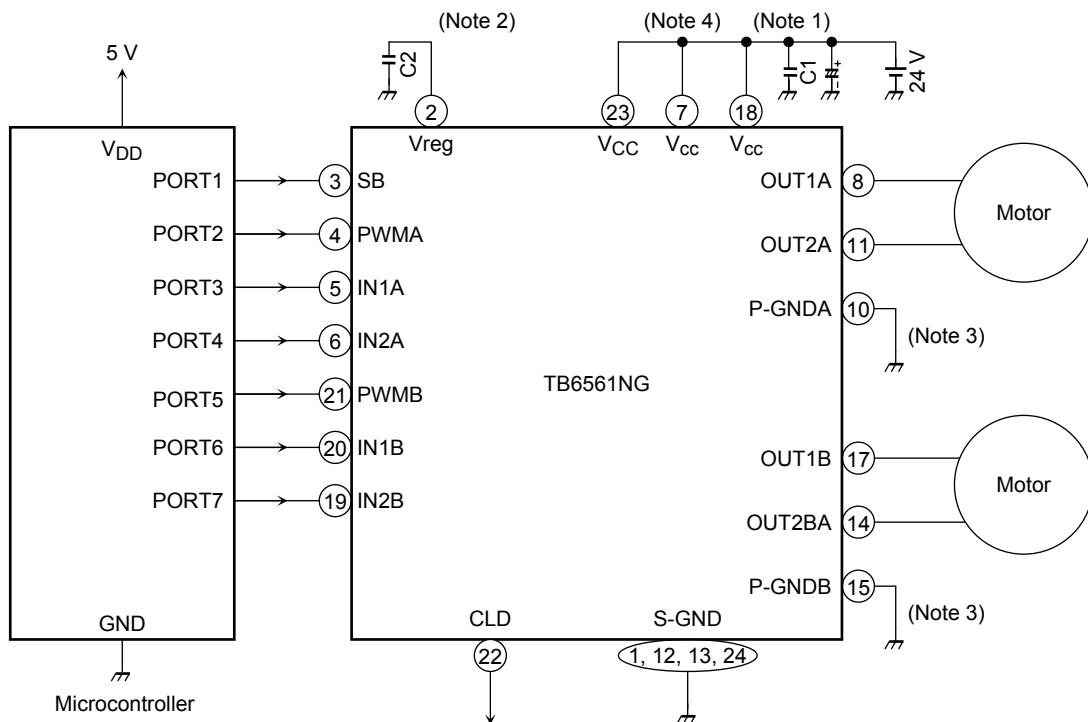

Note 1: A power supply capacitor should be connected between V_{CC} and P-GND as close as possible to the IC.

Note 2: C2 should be connected as close as possible to S-GND.

Note 3: Avoid connecting the resistor to detect the motor current. If necessary, connect the resistor to VM line.

Note 4: V_{CC} (7 pin, 18 pin, 23 pin) should be shorted externally.

Note 5: When the power is turned on, set SB for low (standby mode) or IN1 and IN2 for low (stop mode).

Caution for using

· Utmost care is necessary in the design of the output, V_{CC} , V_M , and GND lines since the IC may be destroyed by short-circuiting between outputs, air contamination faults, or faults due to improper grounding, or by short-circuiting between contiguous pins.

· The IC may be destroyed when mounted in the wrong orientation. Thus, please mount it with great care.

Package Dimensions

SDIP24-P-300-1.78

Unit : mm

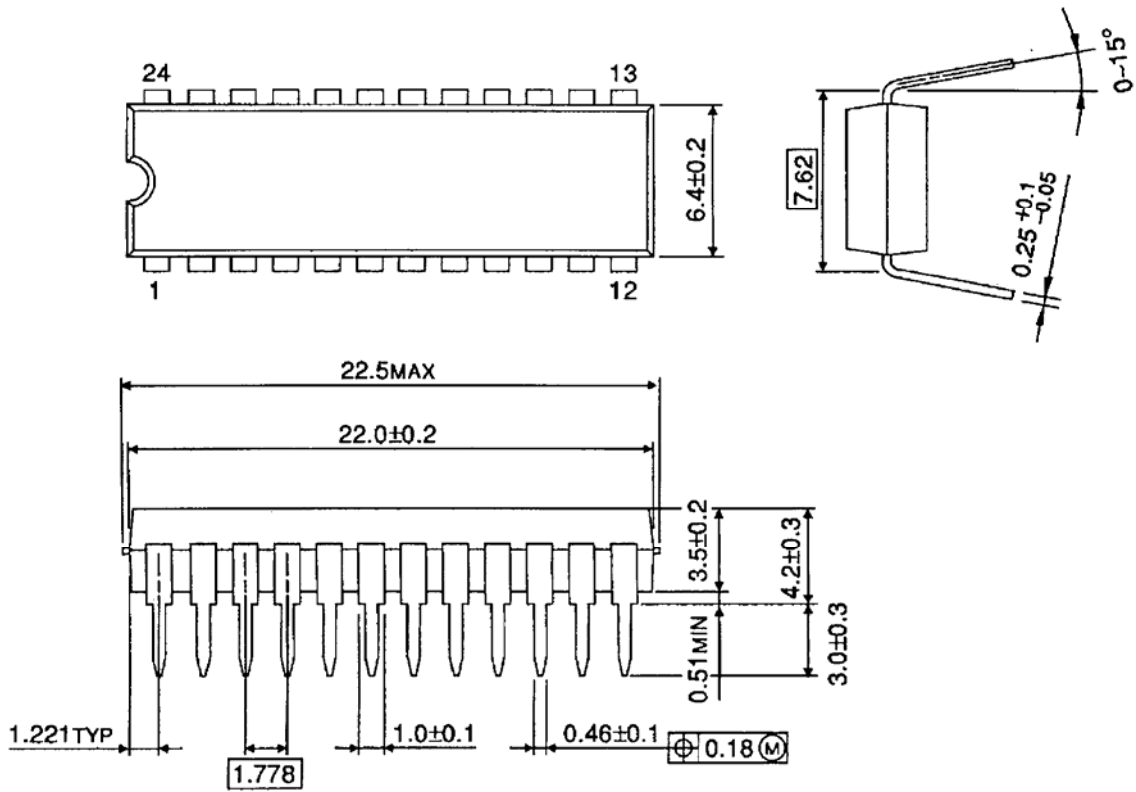

Weight: 1.62 g (typ.)

Notes on Contents

1. Block Diagrams

Some of the functional blocks, circuits, or constants in the block diagram may be omitted or simplified for explanatory purposes.

2. Equivalent Circuits

The equivalent circuit diagrams may be simplified or some parts of them may be omitted for explanatory purposes.

3. Timing Charts

Timing charts may be simplified for explanatory purposes.

4. Application Circuits

The application circuits shown in this document are provided for reference purposes only. Thorough evaluation is required, especially at the mass production design stage.

Toshiba does not grant any license to any industrial property rights by providing these examples of application circuits.

5. Test Circuits

Components in the test circuits are used only to obtain and confirm the device characteristics. These components and circuits are not guaranteed to prevent malfunction or failure from occurring in the application equipment.

IC Usage Considerations

Notes on handling of ICs

- [1] The absolute maximum ratings of a semiconductor device are a set of ratings that must not be exceeded, even for a moment. Do not exceed any of these ratings.
Exceeding the rating(s) may cause the device breakdown, damage or deterioration, and may result injury by explosion or combustion.
- [2] Use an appropriate power supply fuse to ensure that a large current does not continuously flow in case of over current and/or IC failure. The IC will fully break down when used under conditions that exceed its absolute maximum ratings, when the wiring is routed improperly or when an abnormal pulse noise occurs from the wiring or load, causing a large current to continuously flow and the breakdown can lead smoke or ignition. To minimize the effects of the flow of a large current in case of breakdown, appropriate settings, such as fuse capacity, fusing time and insertion circuit location, are required.
- [3] If your design includes an inductive load such as a motor coil, incorporate a protection circuit into the design to prevent device malfunction or breakdown caused by the current resulting from the inrush current at power ON or the negative current resulting from the back electromotive force at power OFF. IC breakdown may cause injury, smoke or ignition.
Use a stable power supply with ICs with built-in protection functions. If the power supply is unstable, the protection function may not operate, causing IC breakdown. IC breakdown may cause injury, smoke or ignition.
- [4] Do not insert devices in the wrong orientation or incorrectly.
Make sure that the positive and negative terminals of power supplies are connected properly. Otherwise, the current or power consumption may exceed the absolute maximum rating, and exceeding the rating(s) may cause the device breakdown, damage or deterioration, and may result injury by explosion or combustion.
In addition, do not use any device that is applied the current with inserting in the wrong orientation or incorrectly even just one time.

Points to remember on handling of ICs**(1) Over current Protection Circuit**

Over current protection circuits (referred to as current limiter circuits) do not necessarily protect ICs under all circumstances. If the Over current protection circuits operate against the over current, clear the over current status immediately.

Depending on the method of use and usage conditions, such as exceeding absolute maximum ratings can cause the over current protection circuit to not operate properly or IC breakdown before operation. In addition, depending on the method of use and usage conditions, if over current continues to flow for a long time after operation, the IC may generate heat resulting in breakdown.

(2) Thermal Shutdown Circuit

Thermal shutdown circuits do not necessarily protect ICs under all circumstances. If the thermal shutdown circuits operate against the over temperature, clear the heat generation status immediately.

Depending on the method of use and usage conditions, such as exceeding absolute maximum ratings can cause the thermal shutdown circuit to not operate properly or IC breakdown before operation.

(3) Heat Radiation Design

In using an IC with large current flow such as power amp, regulator or driver, please design the device so that heat is appropriately radiated, not to exceed the specified junction temperature (T_J) at any time and condition. These ICs generate heat even during normal use. An inadequate IC heat radiation design can lead to decrease in IC life, deterioration of IC characteristics or IC breakdown. In addition, please design the device taking into consideration the effect of IC heat radiation with peripheral components.

(4) Back-EMF

When a motor rotates in the reverse direction, stops or slows down abruptly, a current flow back to the motor's power supply due to the effect of back-EMF. If the current sink capability of the power supply is small, the device's motor power supply and output pins might be exposed to conditions beyond maximum ratings. To avoid this problem, take the effect of back-EMF into consideration in system design.

RESTRICTIONS ON PRODUCT USE

060116EBA

- The information contained herein is subject to change without notice. 021023_D
- TOSHIBA is continually working to improve the quality and reliability of its products. Nevertheless, semiconductor devices in general can malfunction or fail due to their inherent electrical sensitivity and vulnerability to physical stress. It is the responsibility of the buyer, when utilizing TOSHIBA products, to comply with the standards of safety in making a safe design for the entire system, and to avoid situations in which a malfunction or failure of such TOSHIBA products could cause loss of human life, bodily injury or damage to property.
In developing your designs, please ensure that TOSHIBA products are used within specified operating ranges as set forth in the most recent TOSHIBA products specifications. Also, please keep in mind the precautions and conditions set forth in the "Handling Guide for Semiconductor Devices," or "TOSHIBA Semiconductor Reliability Handbook" etc. 021023_A
- The TOSHIBA products listed in this document are intended for usage in general electronics applications (computer, personal equipment, office equipment, measuring equipment, industrial robotics, domestic appliances, etc.). These TOSHIBA products are neither intended nor warranted for usage in equipment that requires extraordinarily high quality and/or reliability or a malfunction or failure of which may cause loss of human life or bodily injury ("Unintended Usage"). Unintended Usage include atomic energy control instruments, airplane or spaceship instruments, transportation instruments, traffic signal instruments, combustion control instruments, medical instruments, all types of safety devices, etc. Unintended Usage of TOSHIBA products listed in this document shall be made at the customer's own risk. 021023_B
- The products described in this document shall not be used or embedded to any downstream products of which manufacture, use and/or sale are prohibited under any applicable laws and regulations. 060106_Q
- The information contained herein is presented only as a guide for the applications of our products. No responsibility is assumed by TOSHIBA for any infringements of patents or other rights of the third parties which may result from its use. No license is granted by implication or otherwise under any patent or patent rights of TOSHIBA or others. 021023_C
- The products described in this document are subject to the foreign exchange and foreign trade laws. 021023_E