

# VSC7324

VITESSE

## Barrington™ – 24x10/100/1000 Ethernet MAC with SPI-4.2 System Interface



### ENABLING ULTRA HIGH DENSITY SWITCH DESIGNS:

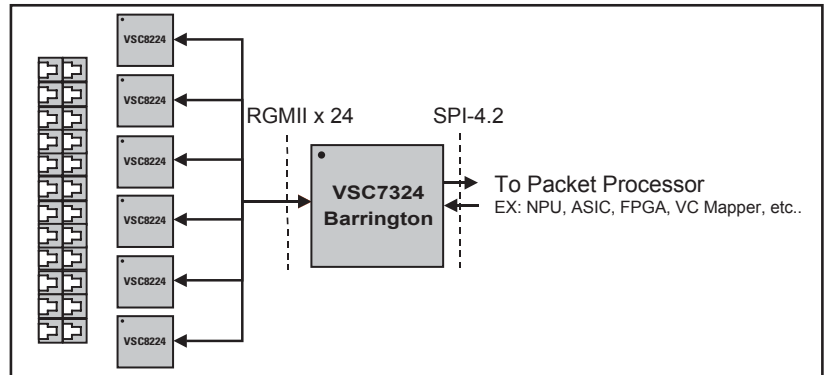

#### FEATURES:

- ▶ 24 Triple Speed Ethernet Ports
- ▶ Intelligent 2:1 Oversubscription
- ▶ High Performance SPI-4.2 System Interface
- ▶ Supports RGMII for connection to copper transceivers.
- ▶ Intelligent Identification and Prioritization of Layer 2 & Layer 3 Control Traffic
- ▶ Per Port Policing & Shaping
- ▶ User Configurable Filtering of Unicast, Multicast & Broadcast Traffic
- ▶ Supports Both Serial & Parallel CPU Access
- ▶ Full RMON 1 Statistics Group and Applicable IEEE 802.3 and SNMP Statistics

#### BENEFITS:

- ▶ Reduces the Number of Components Needed to Build High-density Triple Speed Linecards
- ▶ Eliminates Unused Bandwidth at the Client Interface
- ▶ Enables Seamless Connection to a Variety of Packet Processors.
- ▶ Low Pin-Count, high-Speed Interface simplifies Interconnection of MAC & PHY
- ▶ Maintains Network Stability During Peak Network Utilization
- ▶ Provides user defined fairness During Periods of Oversubscription
- ▶ Filters Unwanted Traffic and Minimizes Congestion During Periods of Oversubscription
- ▶ Flexible Options for Configuration, Control, & Statistical Access
- ▶ Extensive Support for Performance Monitoring and Billing

#### ADVANTAGES:

- ▶ Enables Increased Port Density in Chassis-based Ethernet Switching Platforms.
- ▶ Increased Utilization of Shared Packet Processing Resources
- ▶ Ubiquitous Industry Standard Interface

### GENERAL DESCRIPTION:



*The Barrington family is based on Vitesse's third generation MAC architecture and includes the flagship 24-port VSC7324, the 16-port VSC7325, and the 12-port VSC7326. Each device has advanced traffic over-subscription mechanisms to ensure quality of service and high bandwidth availability during periods of peak network utilization. Combining this capability with extensive per port buffering, high-density platforms such as Ethernet switches and routers can aggregate up to 24 Gigabit Ethernet ports into a single 10 Gbps packet processor. OEMs realize a substantial cost savings by reducing system cost per user without impacting network performance.*

**Barrington (VSC7324)** is an advanced 24-port Triple Speed Ethernet MAC solution with Intelligent Over-subscription enabling low cost, high-density, chassis-based linecards ranging from 24 to 96 ports. Barrington, which is also available in 12 and 16 port versions, is a versatile building block for a range of high-density triple-speed Ethernet applications in the Enterprise, Metro, and Core. Barrington integrates 24 triple-speed MACs, advanced over-subscription mechanisms, an extensive on-chip memory system, an OIF compliant SPI-4.2 interface with support for dynamic deskew, both a 16-bit parallel and a 4-wire serial CPU interface, and dual MII Management interfaces.

As the transition to triple-speed copper interfaces in the Enterprise increases, the need for intelligent over-subscription and control traffic protection functionality is critical to efficient network operation and management. The Barrington family includes advanced over-subscription mechanisms, used to control the bandwidth on each Ethernet port in order to prioritize traffic across all 24-ports. As part of the advanced over-

prioritize traffic across all 24-ports. As part of the advanced over-subscription mechanisms, the Barrington family also prioritizes and protects Layer 2 and Layer 3 control frames to maintain overall network management and efficiency during periods of peak network utilization.

Interfacing to the triple-speed MAC ports is accomplished using the reduced pin count Reduced Gigabit Media Independent Interface (RGMI). On the system side Barrington utilizes an industry standard SPI-4.2 system interface with 24 channels.

The internal ingress (Rx) and egress (Tx) FIFOs, which are provisionable on a per-port basis in increments of 2 kB, are capable of handling short-haul flow control and accommodating bursty traffic between the Ethernet MACs and the SPI-4.2 system interface. The FIFO structures are independently configurable for either cut-through or store-and-forward modes.

The Barrington Family is supported in Vitesse's MAC Application Software (MAS) suite. The MAS is a library of generic ANSI C functions for various Gigabit Ethernet (GbE) and Ten Gigabit Ethernet (10GbE) Media Access Controllers in the Vitesse MAC family. The MAC Application Software provides a common software solution for the Vitesse MAC family beginning with Meigs-II™ and including Meigs-IIe™ and Campbell-I™. The MAC Application Software simplifies the use of these MAC devices by providing a well defined, operating system and processor independent application-programming interface (API).

The Barrington Family is supported by a comprehensive collateral package including application notes, IBIS models, DSDL file, reference schematics, symbols, and University of New Hampshire (UNH) Interoperability Lab (IOL) reports for Fast Ethernet and Gigabit Ethernet test suites.

### BLOCK DIAGRAM:

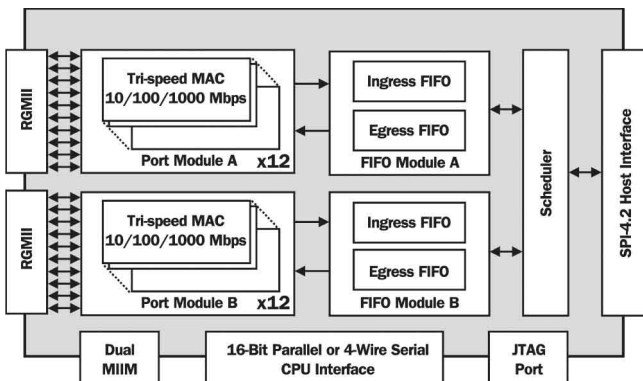

### SPECIFICATIONS:

- ▶ 1.8V Core Power Supply
- ▶ 2.5V & 3.3V Interface Power Supply

For more information on Vitesse Products visit the Vitesse web site at [www.vitesse.com](http://www.vitesse.com) or contact Vitesse Sales at (800) VITESSE or [sales@vitesse.com](mailto:sales@vitesse.com)

## VITESSE

741 Calle Plano  
Camarillo, CA 93012, USA  
Tel: +1 805.388.3700  
Fax: +1 805.987.5896  
[www.vitesse.com](http://www.vitesse.com)