



VN340SP-E

Quad high side smart
Power solid state relay

Features

Type	$V_{\text{demag}}^{(1)}$	$R_{\text{DSon}}^{(1)}$	$I_{\text{out}}^{(1)}$	V_{CC}
VN340SP-E	$V_{\text{CC}}-55\text{V}$	0.2Ω	0.7A	36V

1. Per channel.

- Output current : 0.7A per channel
- Digital I/O's clamped at 32V minimum voltage
- Shorted load and overtemperature protections
- Protection against loss of ground
- Built-in current limiter
- Undervoltage shut-down
- Open drain diagnostic output
- Fast demagnetization of inductive loads
- Conforms to IEC 61131-2

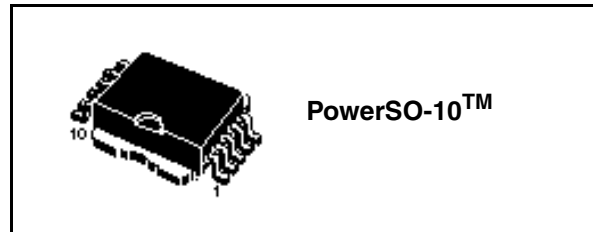

Description

The VN340SP-E is a monolithic device made using STMicroelectronics VIPower technology, intended for driving four independent resistive or inductive loads with one side connected to ground. Active current limitation avoids dropping the system power supply in case of shorted load. Built-in thermal shut-down protects the chip from overtemperature and short circuit. The open drain diagnostic output indicates overtemperature conditions. Each I/O is pulled down when overtemperature condition of the relative channel is verified.

Figure 1. Block diagram

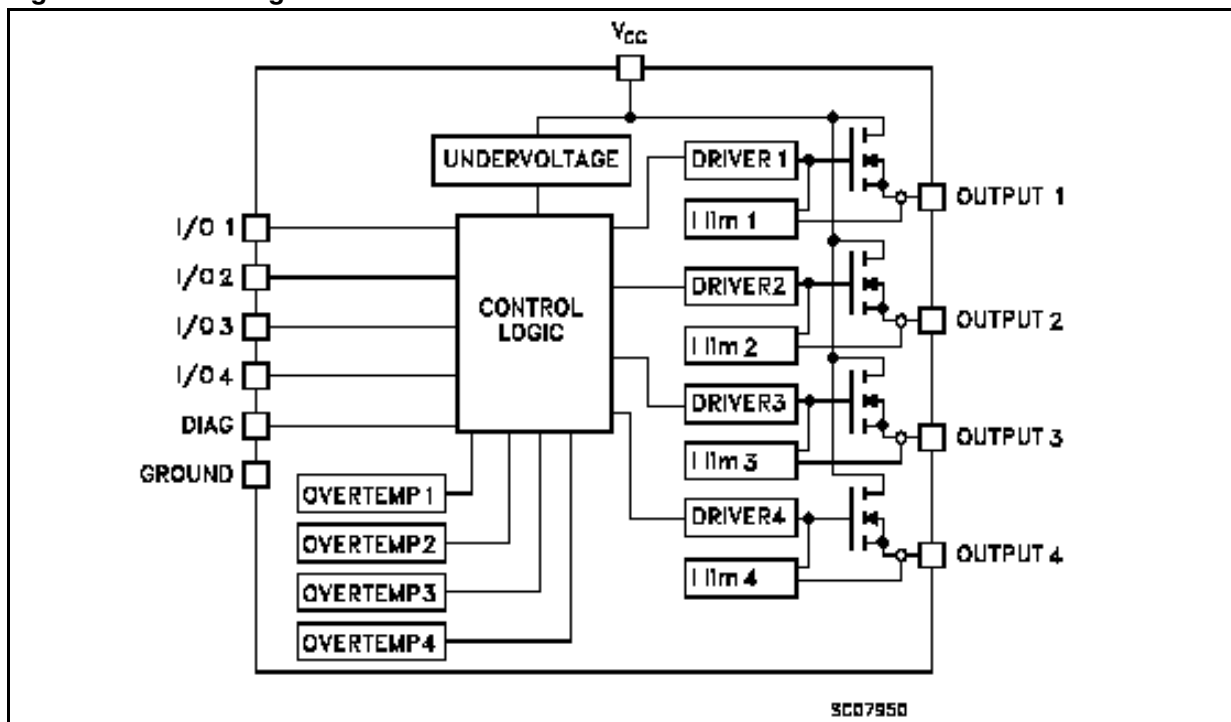

Contents

1	Maximum ratings	3
2	Pin connections	4
3	Electrical characteristics	5
4	Test circuits	7
5	Switching time waveforms and truth table	9
6	Package mechanical data	11
7	Order code	14
8	Revision history	15

1 Maximum ratings

Table 1. Absolute maximum rating

Symbol	Parameter	Value	Unit
V_{CC}	Power supply voltage	45	V
$-V_{CC}$	Reverse supply voltage	-4	V
I_{OUT}	Output current (continuous)	Internally limited	A
I_R	Reverse output current (per channel)	-6	A
I_{IN}	Input current (per channel)	± 10	mA
I_{DIAG}	Diag pin current	± 10	mA
V_{ESD}	Electrostatic discharge (R = 1.5K Ω ; C = 100pF)	2000	V
E_{AS}	Single pulse avalanche energy per channel not simultaneously Figure 4.	400	mJ
P_{tot}	Power dissipation at $T_c = 25^\circ\text{C}$	Internally limited	w
T_J	Junction operating temperature	Internally limited	$^\circ\text{C}$
T_{STG}	Storage temperature	-55 to 150	$^\circ\text{C}$

Table 2. Thermal data

Symbol	Parameter	Max Value	Unit
R_{thJC}	Thermal resistance junction-case ⁽¹⁾	Max 3	$^\circ\text{C}/\text{W}$
R_{thJA}	Thermal resistance junction-ambient ⁽²⁾	Max 50	$^\circ\text{C}/\text{W}$

1. Per channel
2. When mounted using minimum recommended pad size on FR-4 board

2 Pin connections

Figure 2. Connection diagram (top view)

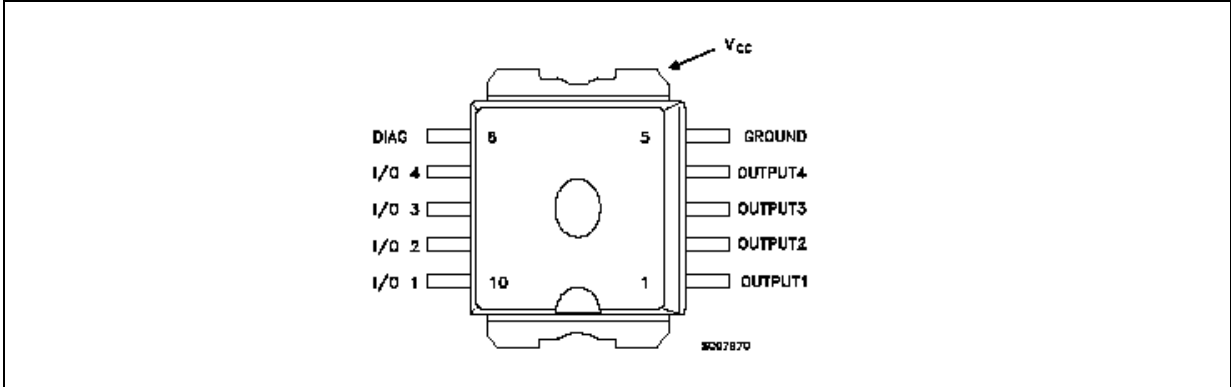
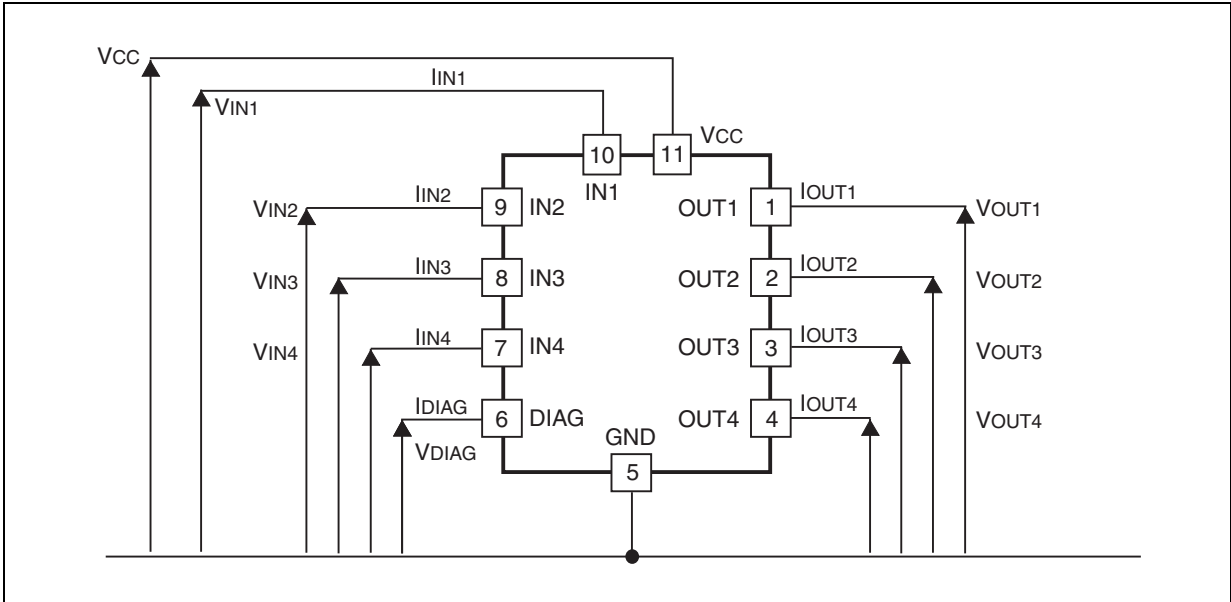

Figure 3. Current and voltage conventions



3 Electrical characteristics

10V < V_{CC} < 36V; -40°C < T_J < 125°C; unless otherwise specified

Table 3. Power section

Symbol	Parameter	Test conditions	Min	Typ	Max	Unit
V _{CC}	Supply voltage		10		36	V
R _{ON}	On state resistance	I _{OUT} = 0.5A; T _J = 25°C I _{OUT} = 0.5A; T _J = 85°C I _{OUT} = 0.5A; T _J = 125°C			0.2 0.32 0.4	Ω Ω Ω
I _S	Supply current	All channels OFF On state; V _{IN} = 30V; I _{OUT} = 0V (T _J = 125°C)			1 6	mA mA
V _{OL}	Low state output voltage	V _{IN} = V _{IL} ; R _{LOAD} ≥ 10MΩ			1.5	V
V _{demag}	Output voltage at turn-off	I _{OUT} = 0.5A; L _{LOAD} ≥ 1mH	V _{CC} -65	V _{CC} -55	V _{CC} -45	V
I _{LGND}	Output current at turn-off	V _{CC} = V _{INn} = V _{GND} = V _{STAT} = 18 to 30V T _{amb} = - 25°C to 85°C Figure 6.			2	mA

Table 4. Switching (V_{CC} = 24V)

Symbol	Parameter	Test conditions	Min	Typ	Max	Unit
t _{d(ON)}	Turn-on delay time of Output current	I _{OUT} = 0.5A, resistive load input rise time < 0.1μs, T _J = 25°C		52	100	μs
t _r	Rise time of output current	I _{OUT} = 0.5A, resistive load input rise time < 0.1μs, T _J = 25°C		94	250	μs
t _{d(OFF)}	Turn-off delay time of output current	I _{OUT} = 0.5A, resistive load input rise time < 0.1μs, T _J = 25°C		34	50	μs
t _f	Fall time of output current	I _{OUT} = 0.5A, resistive load input rise time < 0.1μs, T _J = 25°C		8	20	μs

Table 5. Logical input

Symbol	Parameter	Test conditions	Min	Typ	Max	Unit
V _{IL}	I/O Input low level voltage				2	V
V _{IH}	I/O Input high level voltage ⁽¹⁾		3.5			V
V _{I(HYST)}	I/O Input hysteresis voltage			0.5		V
I _{IN}	I/O Input current	V _{IN} = 30V			25	μA
V _{ICL}	I/O Input clamp voltage ⁽¹⁾	I _{IN} = 1mA I _{IN} = -1mA	32	36 -0.7		V V

1. The input voltage is internally clamped at 32V minimum, it is possible to connect the input pins to an higher voltage via an external resistor calculate to not exceed 10mA

Table 6. Protection and diagnostic

Symbol	Parameter	Test conditions	Min	Typ	Max	Unit
$V_{DIAG}^{(1)}$	Status voltage output low	$I_{DIAG} = 5\text{mA}$ (Fault condition)			1	V
$V_{SCL}^{(1)}$	Status clamp voltage	$I_{DIAG} = 1\text{mA}$	32	36		V
		$I_{DIAG} = 1\text{mA}$		-0.7		V
V_{USD}	Undervoltage shut down		5		8	V
I_{LIM}	DC Short circuit current	$V_{CC} = 24\text{V}; R_{LOAD} < 10\text{m}\Omega$	0.7		2	A
I_{OVPK}	Peak short circuit current	$V_{CC} = 24\text{V}; V_{IN} = 30; R_{LOAD} < 10\text{m}\Omega$			4	A
I_{DIAGH}	Leakage ondiag pin in high state	$V_{DIAG} = 24\text{V}$			25	μA
I_{LOAD}	Output leakage current	$V_{CC} = 10 \text{ to } 36\text{V}; V_{IN} = V_{IL}$			50	μA
t_{SC}	Delay time of current limiter				100	μs
T_{TSD}	Thermal shut down temperature		150	170		$^{\circ}\text{C}$
T_R	Thermal reset temperature		135	155		$^{\circ}\text{C}$

1. Status determination > 100 μs after the switching edge.

Note: If INPUT pin is floating the corresponding channel will automatically switch OFF. If GND pin is disconnected, the channel will switch OFF provided V_{CC} not exceed 36V.

4 Test circuits

Figure 4. Avalance energy test circuit

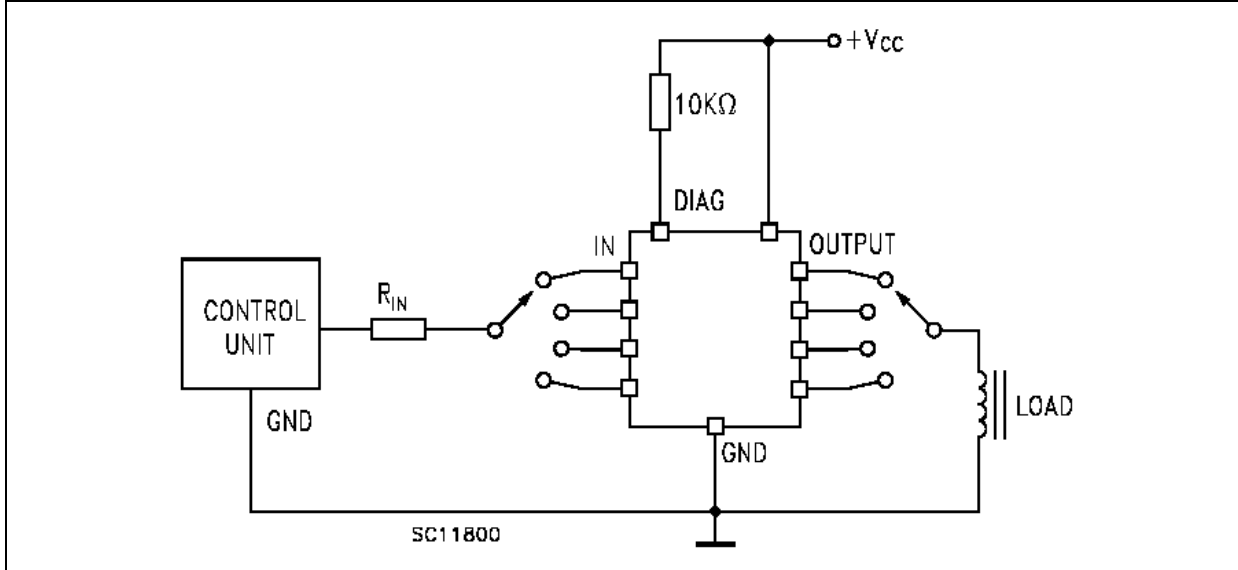

Figure 5. Peak short circuit test diagram

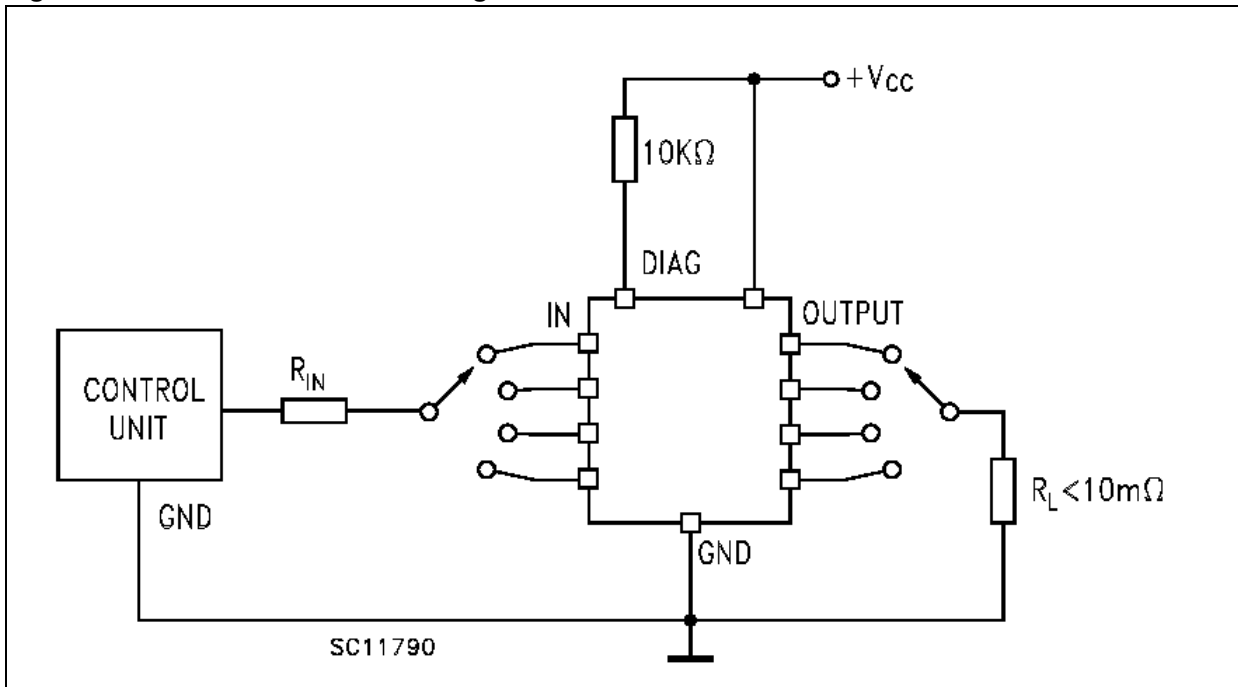
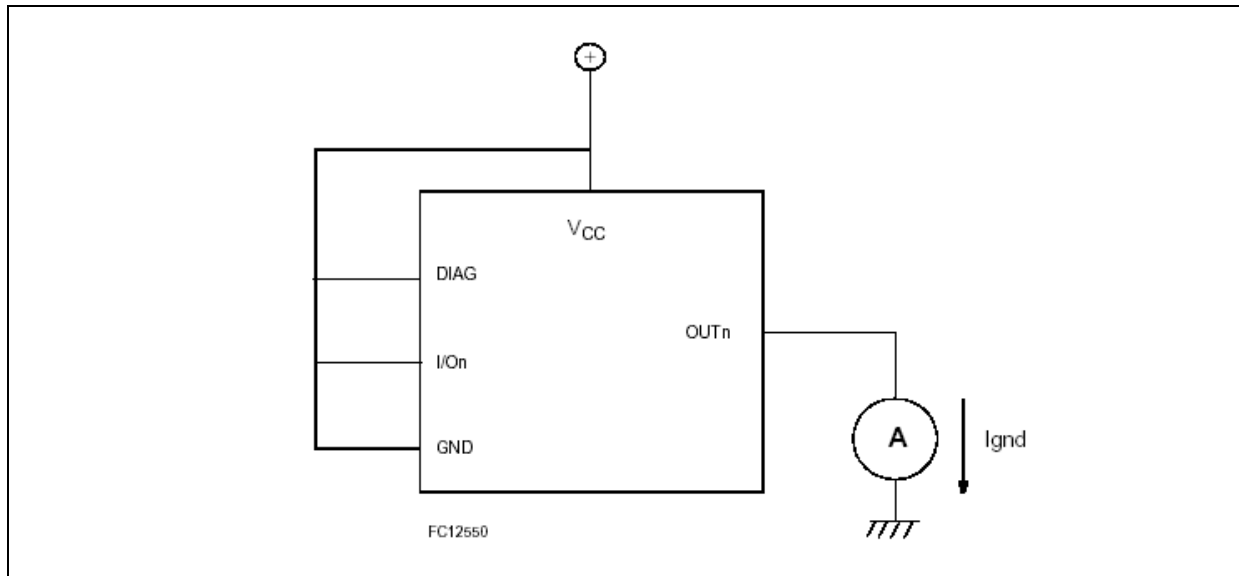

Figure 6. I_{LGND} test configuration



5 Switching time waveforms and truth table

Figure 7. Switching waveforms

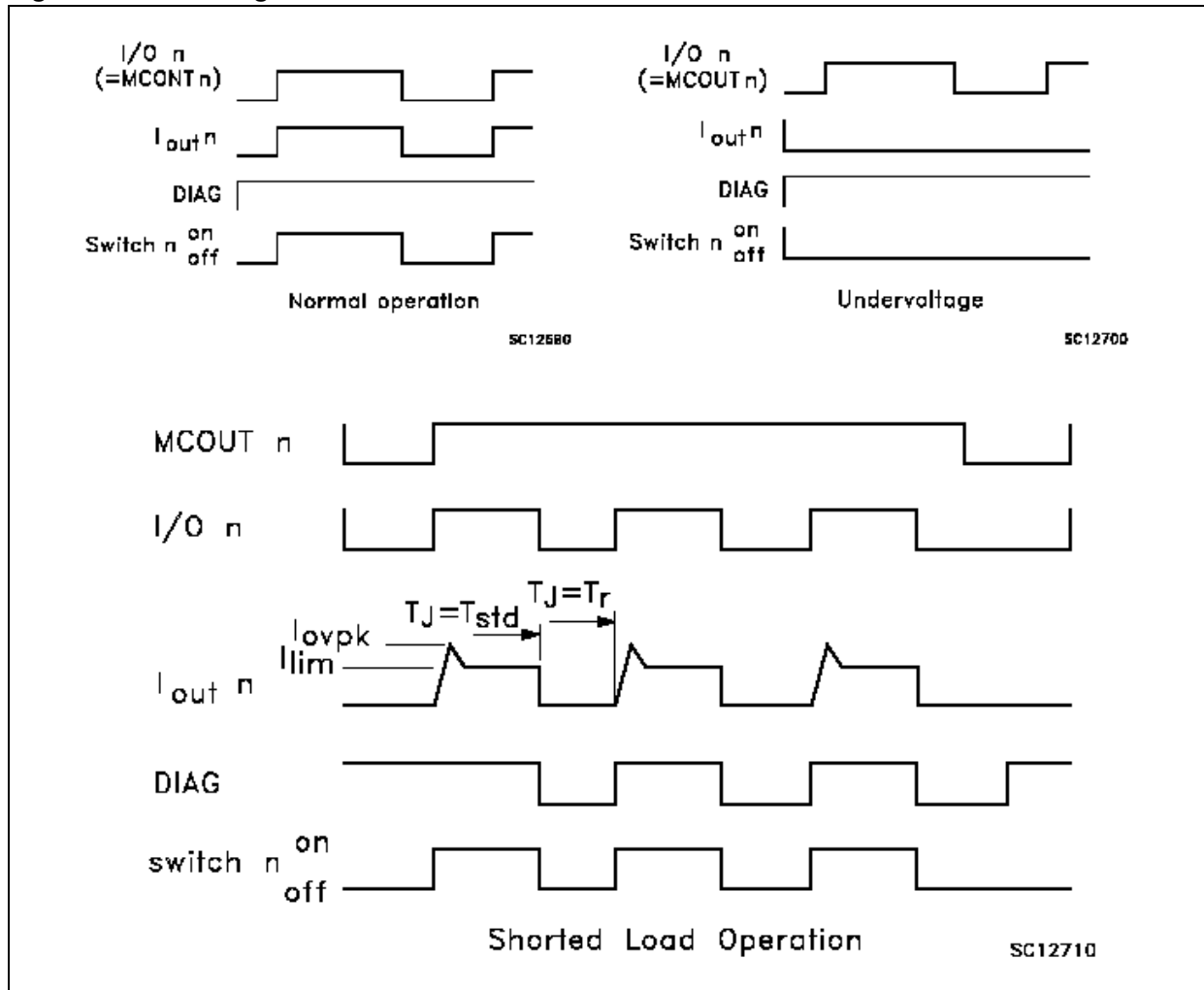

Figure 8. Switching parameter test conditions

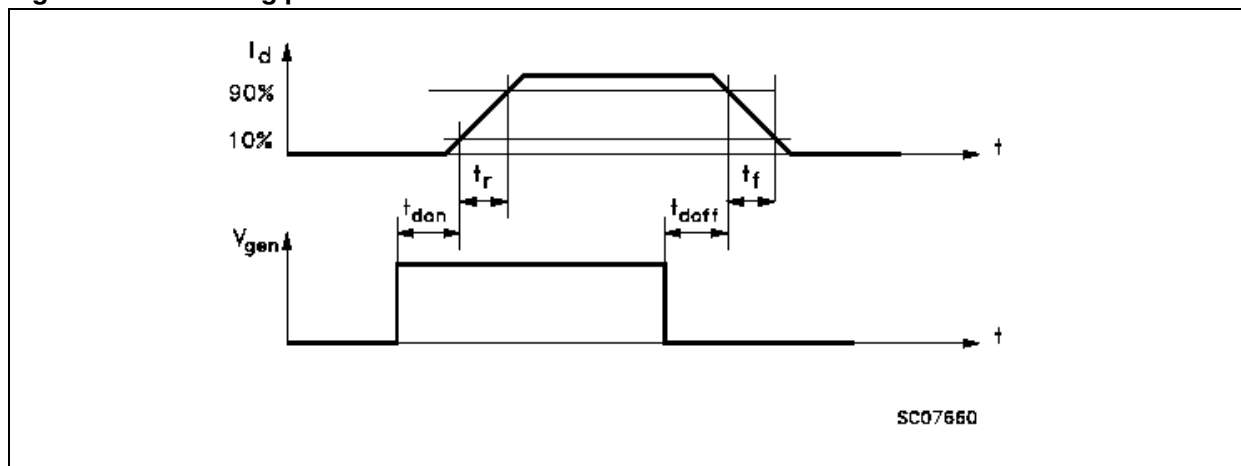
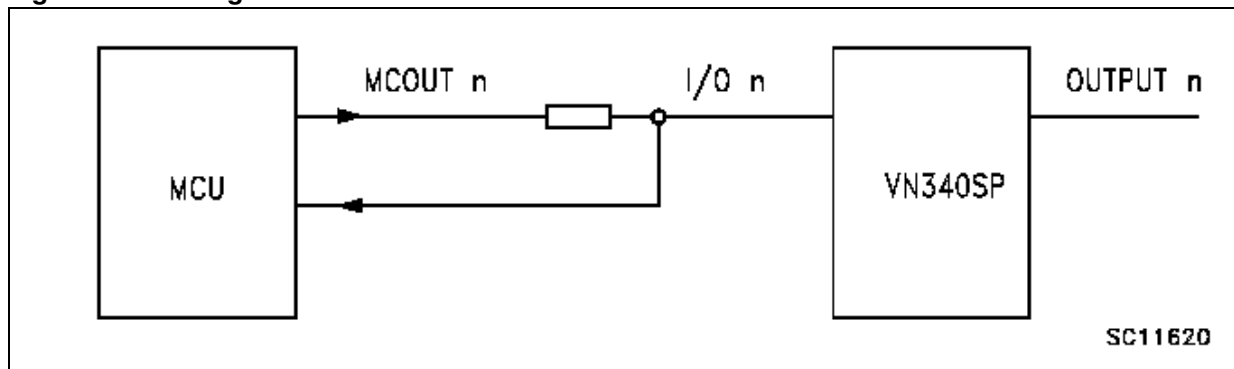

Table 7. Truth table

	MCOUTn	I/O n	OUTPUTn	Diagnostic
Normal operation	L	L	L	H
	H	H	H	H
Overtemperature	L	L	L	H
	H	L	L	L
Undervoltage	L	L	L	H
	H	H	L	H
Shorted load (Current limitation)	L	L	L	H
	H	H	H	H

Figure 9. Driving circuit



6 Package mechanical data

In order to meet environmental requirements, ST offers these devices in ECOPACK® packages. These packages have a Lead-free second level interconnect . The category of second level interconnect is marked on the package and on the inner box label, in compliance with JEDEC Standard JESD97. The maximum ratings related to soldering conditions are also marked on the inner box label. ECOPACK is an ST trademark. ECOPACK specifications are available at: www.st.com

Table 8. PowerSO-10 Mechanical data

Dim	Mm			Inch		
	Min	Typ	Max	Min	Typ	Max
A	3.35		3.65	0.132		0.144
A1	0.00		0.10	0.000		0.004
B	0.40		0.60	0.016		0.024
c	0.23		0.32	0.009		0.012
D	9.40		9.60	0.370		0.378
D1	7.40		7.60	0.291		0.300
E	9.30		9.50	0.366		0.374
E1	7.20		7.40	0.283		0.291
E2	7.20		7.60	0.283		0.300
E3	6.10		6.35	0.240		0.250
E4	5.90		6.10	0.232		0.240
e		1.27			0.050	
F	1.25		1.35	0.049		0.053
H	13.80		14.40	0.543		0.567
h		0.50			0.002	
L	1.20		1.80	0.047		0.071
q		1.70			0.067	
a	0°		8°			

Figure 10. Package dimension

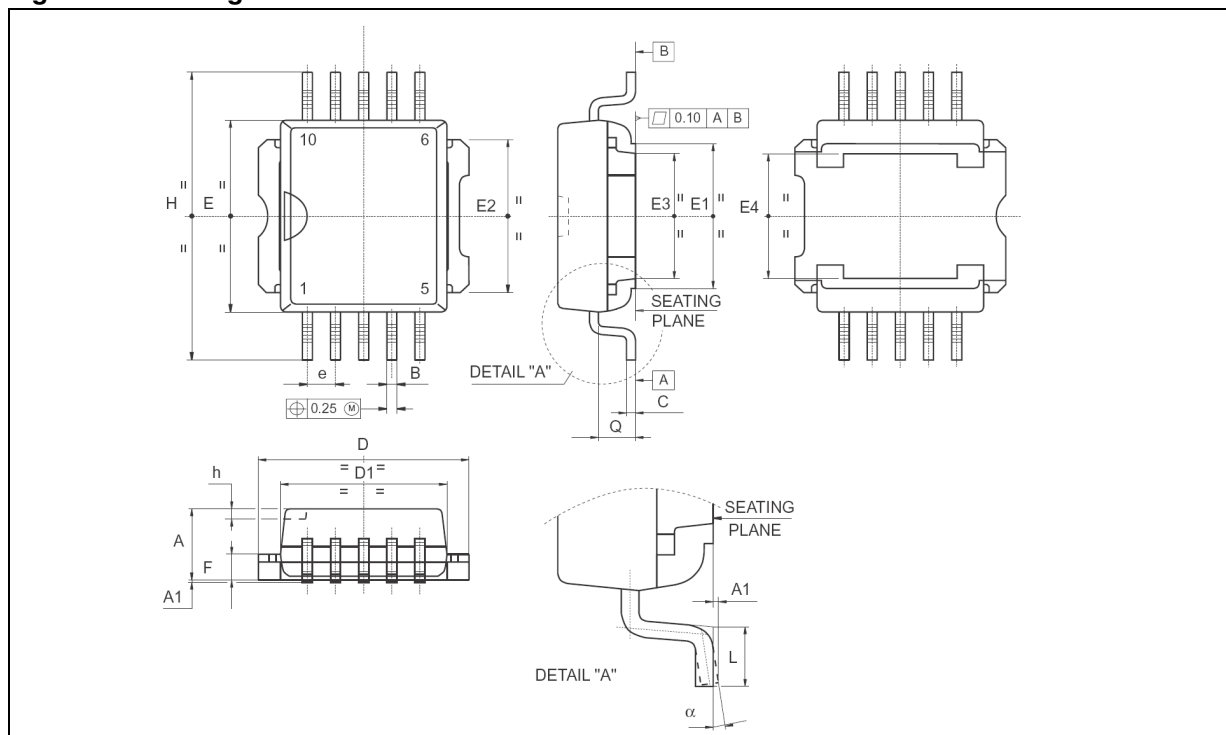

Figure 11. PowerSO-10™ Suggested Pad and Tube Shipment (No Suffix)

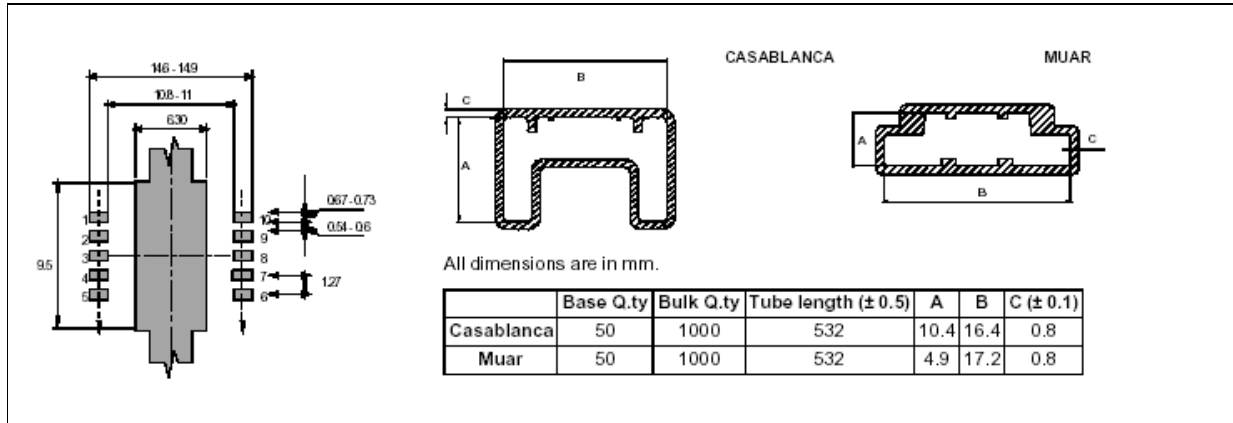
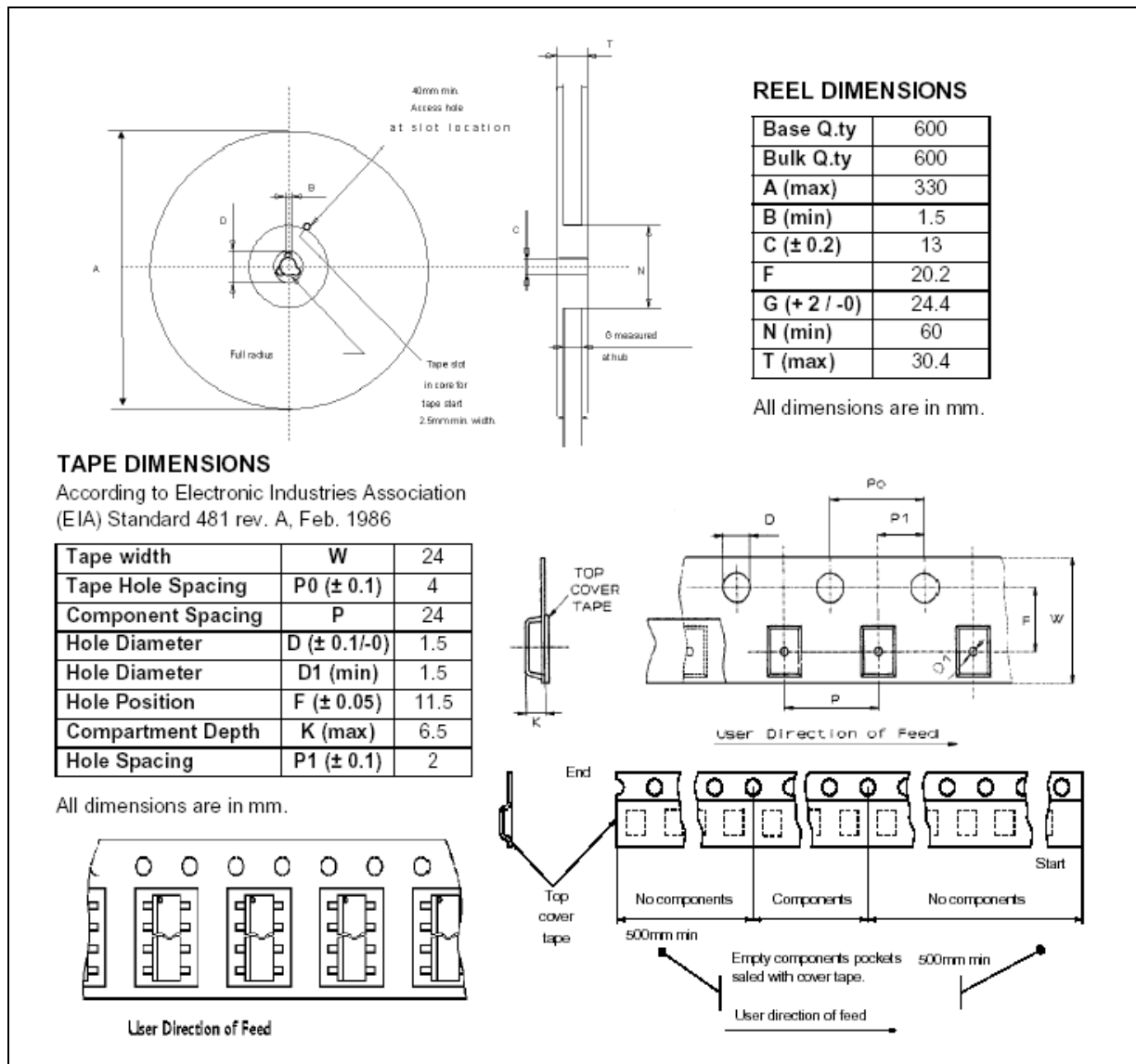

Figure 12. Tape and Reel Shipment (Suffix “TR“)



7 Order code

Table 9. Order code

Part number	Package	Packaging
VN340SP-E	PowerSO-10 TM	Tube
VN340SPTR-E	PowerSO-10 TM	Tape and reel

8 Revision history

Table 10. Revision history

Date	Revision	Changes
5-Sep-2005	1	Initial release
27-Jun-2006	2	Mechanical data updated
18-Sep-2006	3	Mechanical data updated, Added powerSO-10 Tape and reel information
31-Oct-2006	4	Typo in Electrical characteristics temperature conditions updated on page 5
05-Mar-2007	5	Document reformatted, typo in Note 1 on page 6

Please Read Carefully:

Information in this document is provided solely in connection with ST products. STMicroelectronics NV and its subsidiaries ("ST") reserve the right to make changes, corrections, modifications or improvements, to this document, and the products and services described herein at any time, without notice.

All ST products are sold pursuant to ST's terms and conditions of sale.

Purchasers are solely responsible for the choice, selection and use of the ST products and services described herein, and ST assumes no liability whatsoever relating to the choice, selection or use of the ST products and services described herein.

No license, express or implied, by estoppel or otherwise, to any intellectual property rights is granted under this document. If any part of this document refers to any third party products or services it shall not be deemed a license grant by ST for the use of such third party products or services, or any intellectual property contained therein or considered as a warranty covering the use in any manner whatsoever of such third party products or services or any intellectual property contained therein.

UNLESS OTHERWISE SET FORTH IN ST'S TERMS AND CONDITIONS OF SALE ST DISCLAIMS ANY EXPRESS OR IMPLIED WARRANTY WITH RESPECT TO THE USE AND/OR SALE OF ST PRODUCTS INCLUDING WITHOUT LIMITATION IMPLIED WARRANTIES OF MERCHANTABILITY, FITNESS FOR A PARTICULAR PURPOSE (AND THEIR EQUIVALENTS UNDER THE LAWS OF ANY JURISDICTION), OR INFRINGEMENT OF ANY PATENT, COPYRIGHT OR OTHER INTELLECTUAL PROPERTY RIGHT.

UNLESS EXPRESSLY APPROVED IN WRITING BY AN AUTHORIZED ST REPRESENTATIVE, ST PRODUCTS ARE NOT RECOMMENDED, AUTHORIZED OR WARRANTED FOR USE IN MILITARY, AIR CRAFT, SPACE, LIFE SAVING, OR LIFE SUSTAINING APPLICATIONS, NOR IN PRODUCTS OR SYSTEMS WHERE FAILURE OR MALFUNCTION MAY RESULT IN PERSONAL INJURY, DEATH, OR SEVERE PROPERTY OR ENVIRONMENTAL DAMAGE. ST PRODUCTS WHICH ARE NOT SPECIFIED AS "AUTOMOTIVE GRADE" MAY ONLY BE USED IN AUTOMOTIVE APPLICATIONS AT USER'S OWN RISK.

Resale of ST products with provisions different from the statements and/or technical features set forth in this document shall immediately void any warranty granted by ST for the ST product or service described herein and shall not create or extend in any manner whatsoever, any liability of ST.

ST and the ST logo are trademarks or registered trademarks of ST in various countries.

Information in this document supersedes and replaces all information previously supplied.

The ST logo is a registered trademark of STMicroelectronics. All other names are the property of their respective owners.

© 2007 STMicroelectronics - All rights reserved

STMicroelectronics group of companies

Australia - Belgium - Brazil - Canada - China - Czech Republic - Finland - France - Germany - Hong Kong - India - Israel - Italy - Japan - Malaysia - Malta - Morocco - Singapore - Spain - Sweden - Switzerland - United Kingdom - United States of America

www.st.com