

TOSHIBA CMOS Digital Integrated Circuit Silicon Monolithic

TC7WPB306FC,TC7WPB306FK TC7WPB307FC,TC7WPB307FK

Low Voltage/Low Power 2-Bit Dual Supply Bus Switch

The TC7WPB306 and TC7WPB307 are high-speed CMOS two-bit bus switches with low ON-resistance that allow interfacing between different voltage nodes.

These devices have two separate power supplies, VL for a 1.8-V, 2.5-V or 3.3-V bus and VH for a 2.5-V, 3.3-V or 5.0-V bus.

For bidirectional level-shifting, the VH pin is connected to a high-voltage power supply through a bias resistor, and pull-up resistors are connected between the high-voltage power supply and the switch.

The enable signal can be used to disable the device so that the buses are effectively isolated.

For the TC7WPB306, Output Enable (OE) is active-High: When OE is High, the switch is on; when Low, the switch is off. For the TC7WPB307, Output Enable (\overline{OE}) is active-Low: When \overline{OE} is Low, the switch is on; when High, the switch is off.

The TC7WP306 and TC7WP307 support power-down protection by incorporating 5.5-V-tolerant control inputs.

The bus switch channels are fabricated with NMOS technology.

All inputs are equipped with protection circuits against static discharge or transient excess voltage.

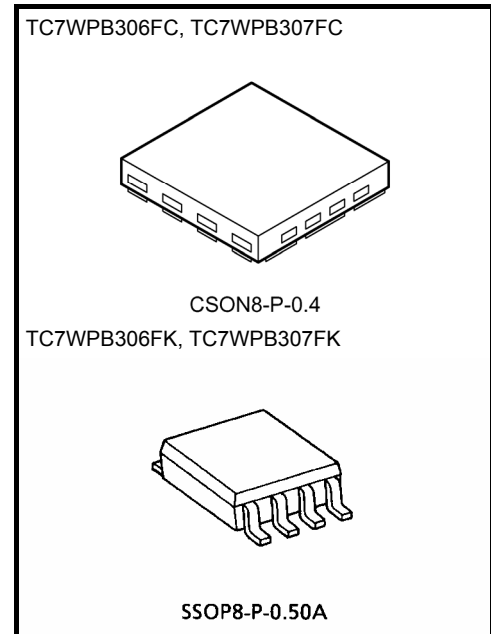

Weight

CSON8-P-0.4 : 0.002 g (typ.)

SSOP8-P-0.50A : 0.01 g (typ.)

Features

- Operating voltage: 1.8-V to 2.5-V, 1.8-V to 3.6-V, 1.8-V to 5.5-V, 2.3-V to 3.6-V, 2.3-V to 5.5-V or 3.0-V to 5.5-V bidirectional interface
- Operating voltage: VL = 1.65 to 5.0 V, VH = VL + 0.5 to 5.5 V
- High-speed operation: $t_{pd} = 0.12\text{ns}(\text{max})$
(VL = 3.0 V, VH = 4.5 V)
- Low ON-resistance: $R_{ON} = 3.0 \Omega$ (typ.)
(ON-resistance test circuit: $V_{IS} = 0 \text{ V}$, $I_{IS} = 30 \text{ mA}$, $V_H = 4.5 \text{ V}$)
- ESD performance: Machine model $\geq \pm 200 \text{ V}$
Human body model $\geq \pm 2000 \text{ V}$
- 5.5-V tolerance and power-down protection at the Output Enable input.
- Packages: CSON8 (CST8), SSOP8 (US8)

Pin Assignment (top view), Marking

TC7WPB306FC

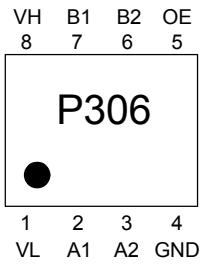
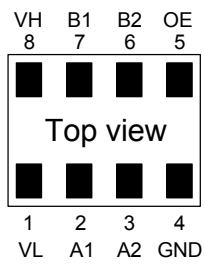

TC7WPB306FK

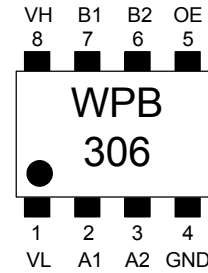

TC7WPB307FC

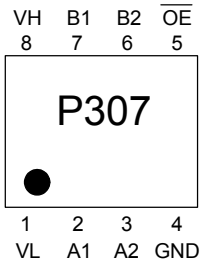
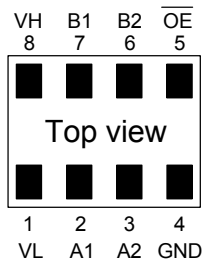

TC7WPB307FK

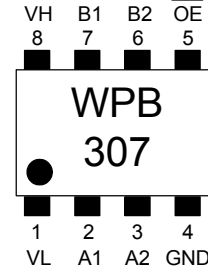

Truth Table

Input (306)	Function	Input (307)	Function
OE		\overline{OE}	
H	$A_n = B_n$	H	Disconnected
L	Disconnected	L	$A_n = B_n$

Circuit Schematic

TC7WPB306

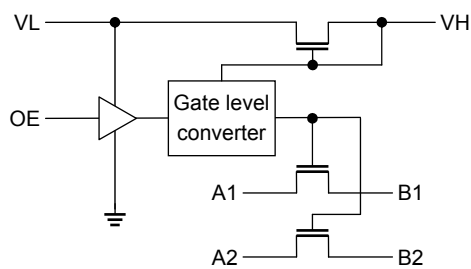

TC7WPB307

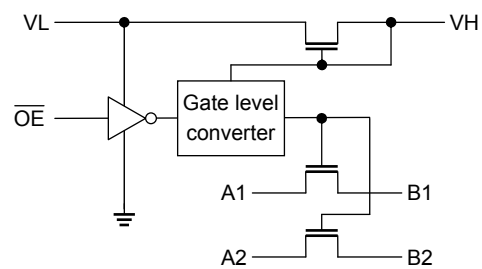

Absolute Maximum Ratings (Note)

Characteristics	Symbol	Rating	Unit
Power supply voltage	VL	-0.5 to 7.0	V
	VH	-0.5 to 7.0	
Control input voltage (OE (306)/OE (307))	V _{IN}	-0.5 to 7.0	V
Switch input/output voltage	V _S	-0.5 to 7.0	V
Clump diode current	I _{IK}	-50	mA
Switch input/output current	I _S	128	mA
DC V _{CC} /ground current per supply pin	I _{VL}	±25	mA
	I _{VH}	±25	
Power dissipation	P _D	150 (CSON8) 200 (SSOP8)	mW
Storage temperature	T _{stg}	-65 to 150	°C

Note: Exceeding any of the absolute maximum ratings, even briefly, lead to deterioration in IC performance or even destruction.

Using continuously under heavy loads (e.g. the application of high temperature/current/voltage and the significant change in temperature, etc.) may cause this product to decrease in the reliability significantly even if the operating conditions (i.e. operating temperature/current/voltage, etc.) are within the absolute maximum ratings and the operating ranges.

Please design the appropriate reliability upon reviewing the Toshiba Semiconductor Reliability Handbook ("Handling Precautions"/"Derating Concept and Methods") and individual reliability data (i.e. reliability test report and estimated failure rate, etc).

Operating Ranges (Note 1)

Characteristics	Symbol	Rating	Unit
Power supply voltage (Note 2)	VL	1.65 to 5.0	V
	VH	2.3 to 5.5	
Control input voltage	V _{IN}	0 to 5.5	V
Switch input/output voltage	V _S	0 to 5.5	V
Operating temperature	T _{opr}	-40 to 85	°C
Control input rise and fall times	dt/dv	0 to 10	ns/V

Note 1: The operating ranges must be maintained to ensure the normal operation of the device.

Note 2: The voltage difference between the VL and the VH must be 0.5 V or greater. (VL < VH)

Application Circuit

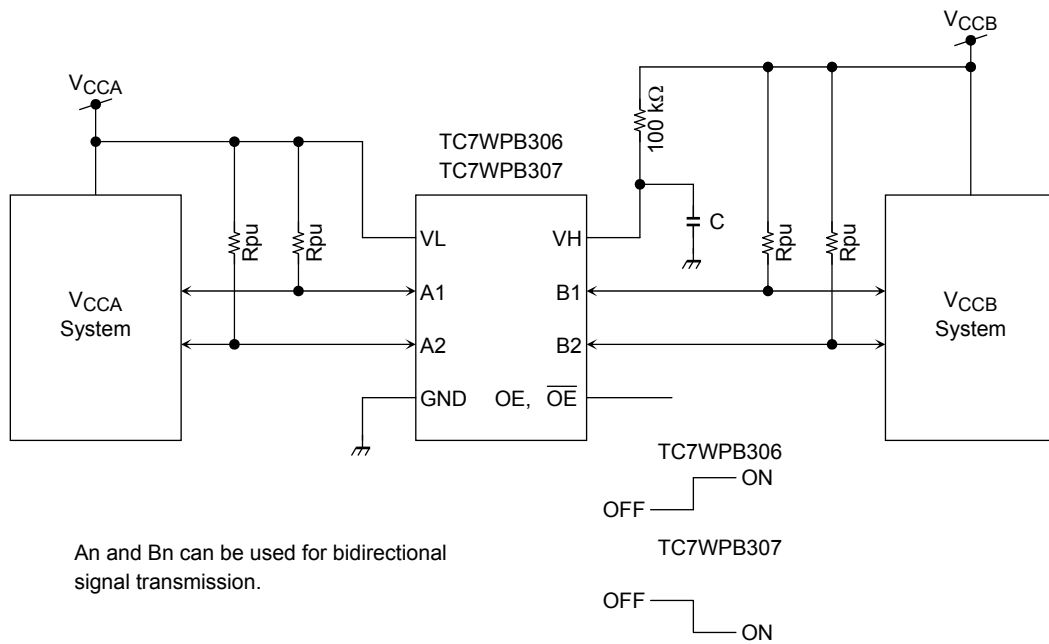

Figure 1 Application Circuit Diagram

The voltage difference between the (low-voltage) V_{CCA} system and the (high-voltage) V_{CCB} system must be 0.5 V or greater. ($V_{CCA} < V_{CCB}$)

For level-shifting between the V_{CCA} and V_{CCB} systems, connect a bias resistor between the VH pin and the V_{CCB} system, and also connect pull-up resistors to An and Bn pins.

Electrical Characteristics

DC Characteristics (Ta = -40 to 85°C)

Characteristics		Symbol	Test Condition	VL (V)	VH (V)	Ta = -40 to 85°C		Unit
						Min	Max	
Control input voltage	High-level	V _{IH}	OE (306), \overline{OE} (307)	1.65 ≤ VL < 2.3	(VL + 0.5) to 5.5	0.8 × VL	—	V
				2.3 ≤ VL ≤ 5.0	(VL + 0.5) to 5.5	0.7 × VL	—	
	Low-level	V _{IL}	OE (306), \overline{OE} (307)	1.65 ≤ VL < 2.3	(VL + 0.5) to 5.5	—	0.2 × VL	
				2.3 ≤ VL ≤ 5.0	(VL + 0.5) to 5.5	—	0.3 × VL	
ON-resistance (Note)	R _{ON}	V _{IS} = 0 V, I _{IS} = 30 mA (Figure 2)	—	2.3	—	9.5	Ω	
			—	3.0	—	7.0		
			—	4.5	—	5.5		
Power off leakage current	I _{OFF}	A _n , B _n = 0 ~ 5.5V	0	0	—	±1.0	μA	
Switch-off leakage current	I _{SZ}	A _n , B _n = 0 to 5.5 V \overline{OE} = VL, OE = GND	1.65 to 5.0	(VL + 0.5) to 5.5	—	±1.0	μA	
Control input current	I _{IN}	\overline{OE} or OE = 0 to 5.5 V	1.65 to 5.0	(VL + 0.5) to 5.5	—	±1.0	μA	
Quiescent supply current	I _{VL1}	V _{IN} = VL or GND, I _S = 0 A	1.65 to 5.0	VL	—	2.0	μA	
	I _{VH1}	V _{IN} = VL or GND, I _S = 0 A	1.65 to 5.0	VL	—	2.0		
	I _{VL2}	VL ≤ V _{IN} ≤ 5.5 V, I _S = 0 A	1.65 to 5.0	VL	—	±2.0		
	I _{VH2}	VL ≤ V _{IN} ≤ 5.5 V, I _S = 0 A	1.65 to 5.0	VL	—	±2.0		

Note: ON-resistance is measured by measuring the voltage drop across the switch at the indicated current. It depends on the VH voltage.

AC Characteristics (Ta = -40 to 85°C, Input: tr = tf = 2.0 ns, f=10kHz)

VL (VCCA) = 3.3 ± 0.3 V, VCCB = 5.0 ± 0.5 V

Characteristics	Symbol	Test Condition	Min	Max	Unit
Propagation delay time (A → B)	t _{pLH} t _{pHL}	Figures 3 and 5	—	0.12	ns
3-state output enable time (OE or \overline{OE} → B)	t _{pZL}	Figures 4 and 6	—	6.5	
3-state output disable time (OE or \overline{OE} → B)	t _{pLZ}	Figures 4 and 6	—	10.5	

VL (VCCA) = 2.5 ± 0.2 V, VCCB = 5.0 ± 0.5 V

Characteristics	Symbol	Test Condition	Min	Max	Unit
Propagation delay time (A → B)	t _{pLH} t _{pHL}	Figures 3 and 5	—	0.12	ns
3-state output enable time (OE or \overline{OE} → B)	t _{pZL}	Figures 4 and 6	—	8.5	
3-state output disable time (OE or \overline{OE} → B)	t _{pLZ}	Figures 4 and 6	—	12.0	

VL (VCCA) = 2.5 ± 0.2 V, VCCB = 3.3 ± 0.3 V

Characteristics	Symbol	Test Condition	Min	Max	Unit
Propagation delay time (A → B)	t _{pLH} t _{pHL}	Figures 3 and 5	—	0.15	ns
3-state output enable time (OE or \overline{OE} → B)	t _{pZL}	Figures 4 and 6	—	9.5	
3-state output disable time (OE or \overline{OE} → B)	t _{pLZ}	Figures 4 and 6	—	12.0	

Capacitive Characteristics (Ta = 25°C)

Characteristics	Symbol	Test Condition			Typ.	Unit
			VL (V)	VH (V)		
Control input capacitance	C _{IN}		3.3	3.3	3	pF
Switch input/output capacitance	C _{I/O}	SW = OFF	3.3	3.3	10	pF

DC Test Circuits

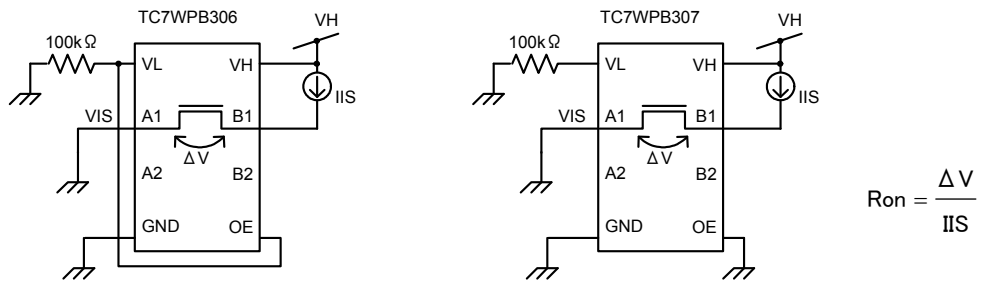

Figure 2 ON-resistance Test Circuits

AC Test Circuits

- tpLH,HL

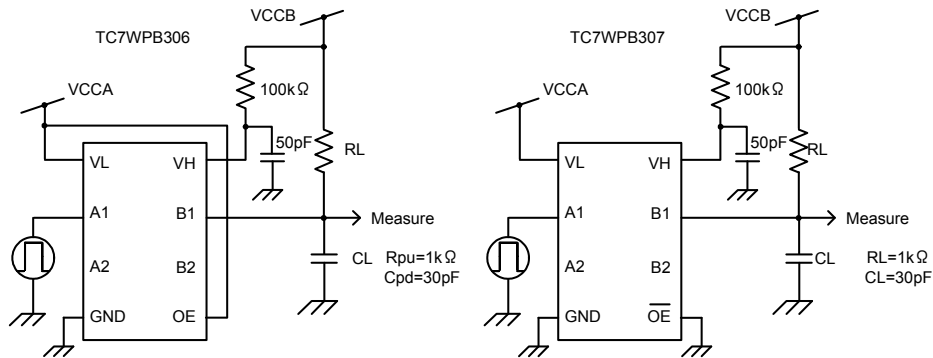

Figure3 tpLH,tpHL Test Circuits

- tpLZ,ZL

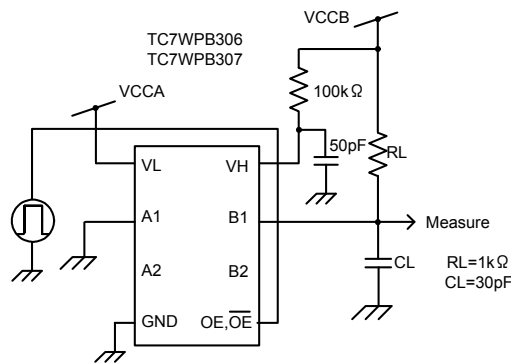

Figure4 tpLZ,tpZL Test Circuits

AC Waveform

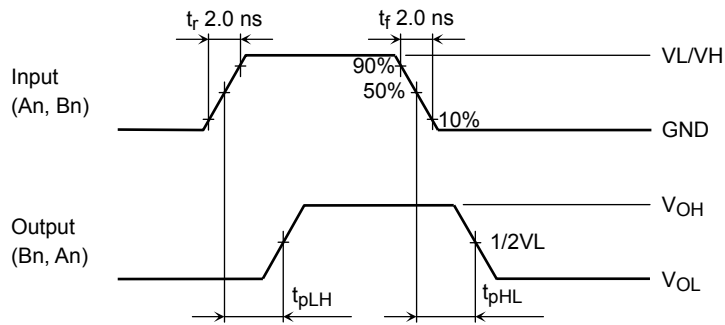

Figure5 tpLH,tpHL

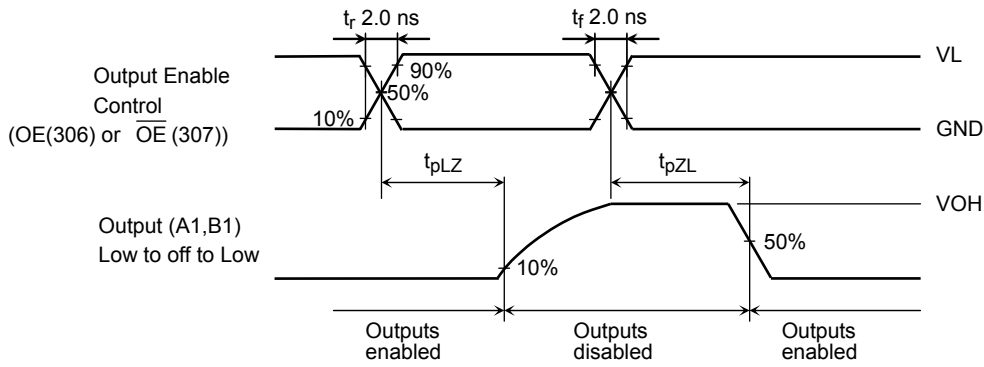

Figure6 tpLZ,tpZL

tpZ Characteristics

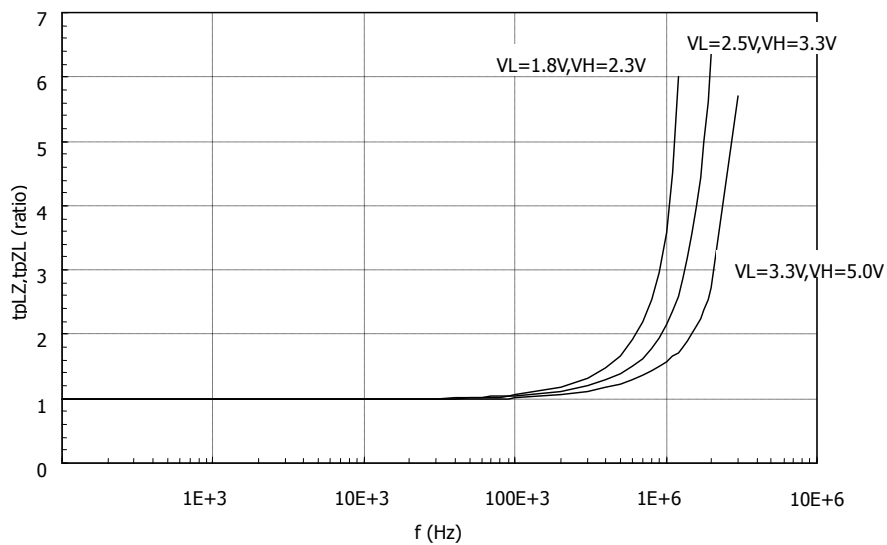

Figure7 tpLZ,tpZL Frequency Characteristic

This figure shows the ratio of delay time for $tpLZ$ and $tpZL$ at the frequency characteristic of OE or /OE when $tpLZ$ and $tpZL$ at the OE or /OE frequency by 10kHz are assumed to be one.

Level Shift Function (Used Pull-up Resistance)

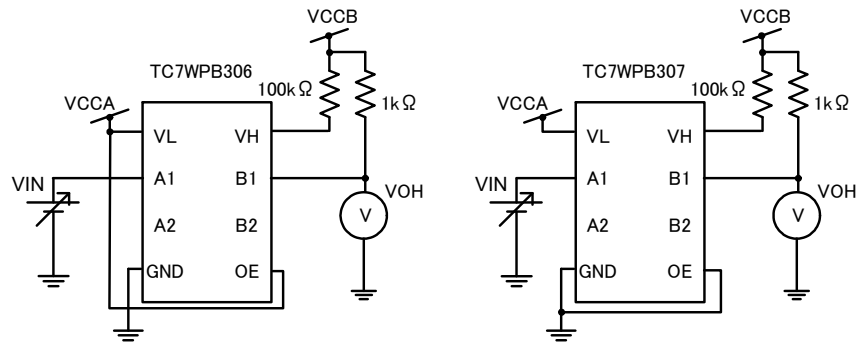

Figure8 Test Circuits

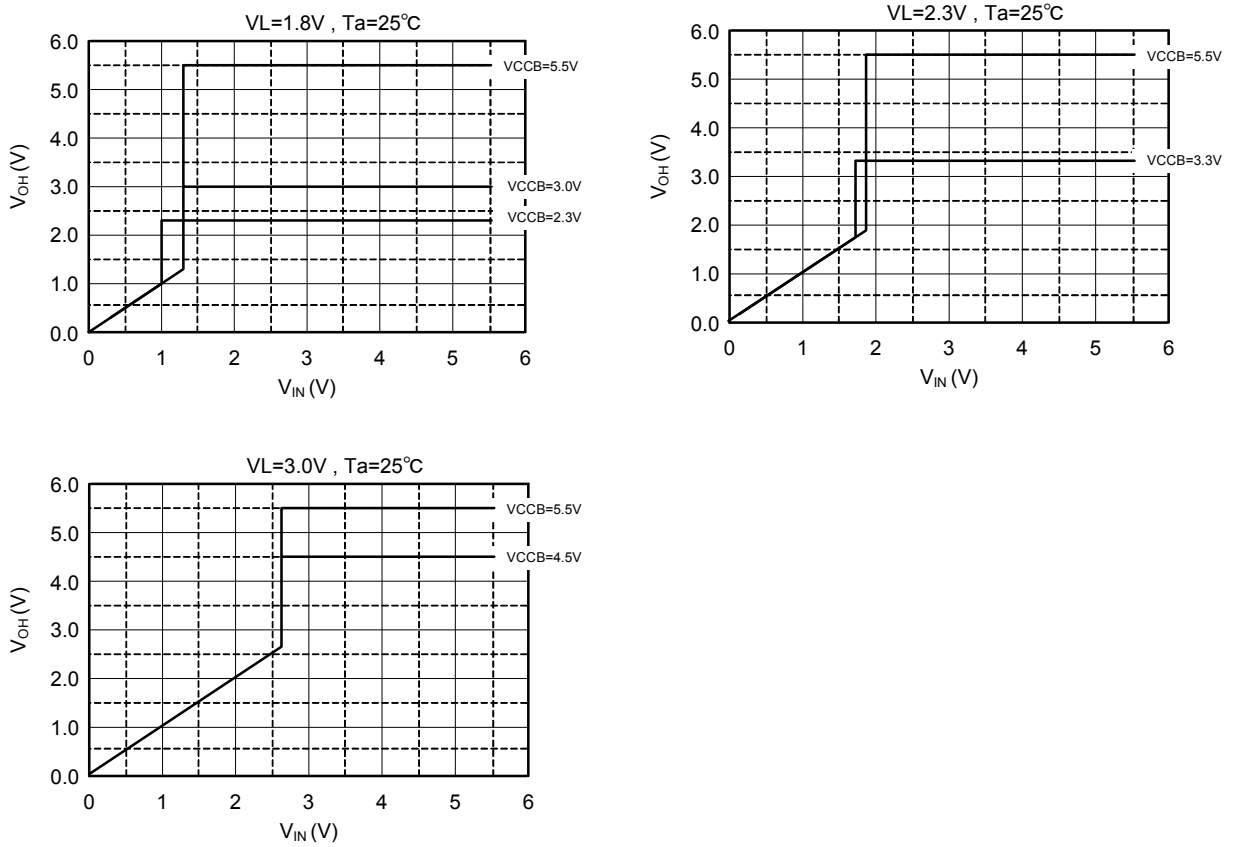

Figure9 Input/Output Characteristics (Typ.)

Level Shift Function (Unused Pull-up Resistance)

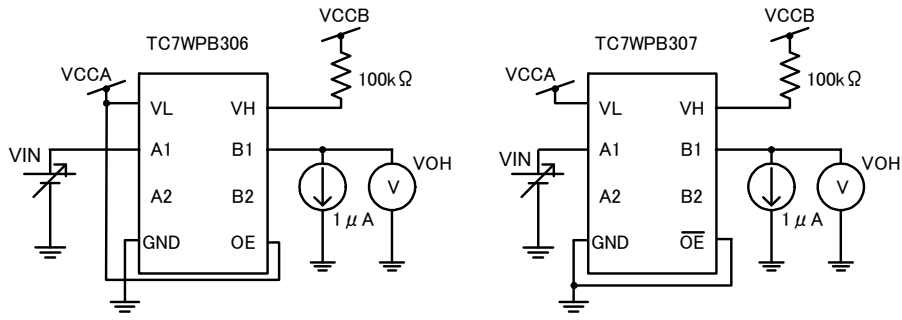

Figure 10 Test Circuits

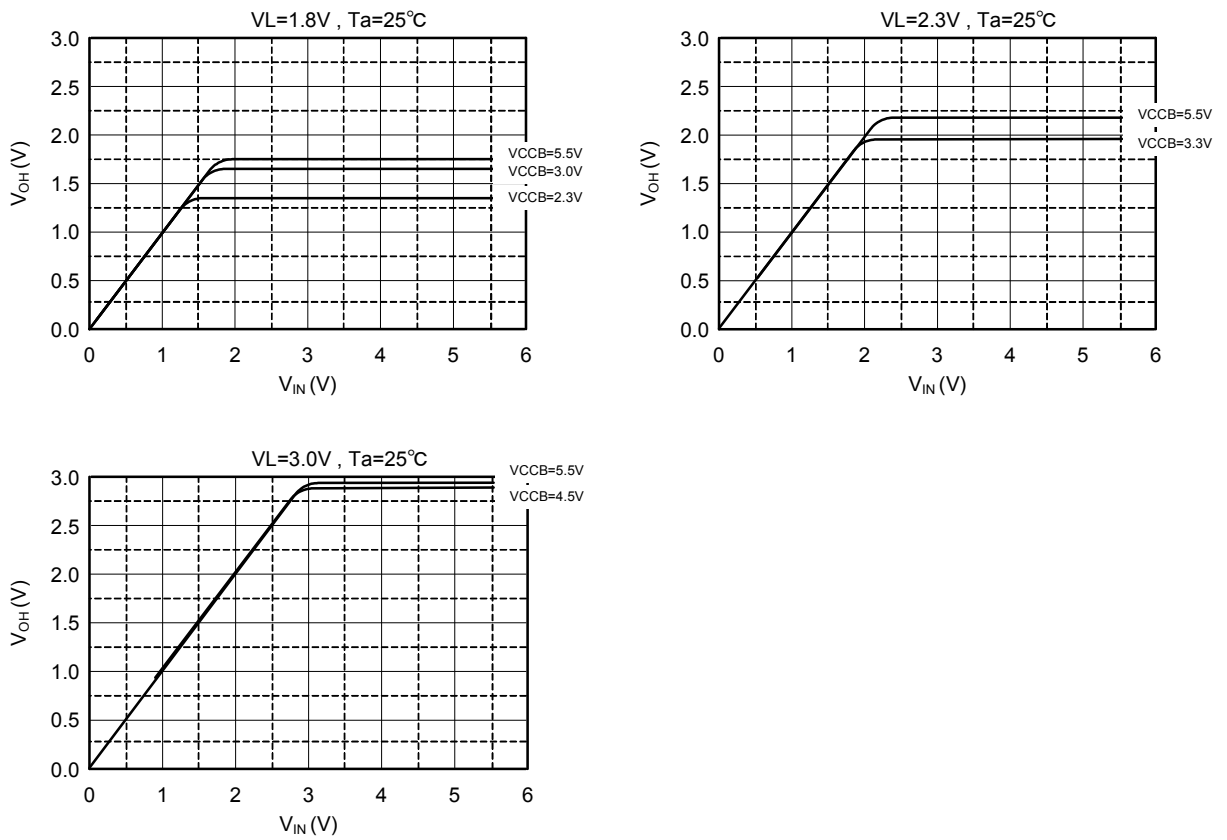
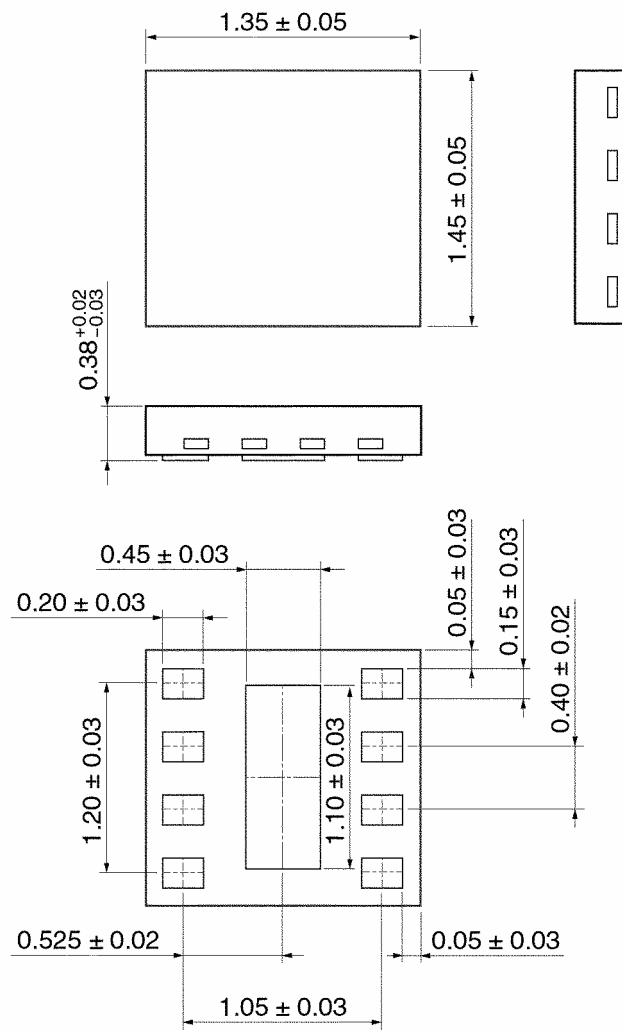

Figure11 Input/Output Characteristics (Typ.)

Package Dimensions

CSON8-P-0.4

Unit: mm



Weight: 0.002 g (typ.)

Package Dimensions

SSOP8-P-0.50A

Unit : mm

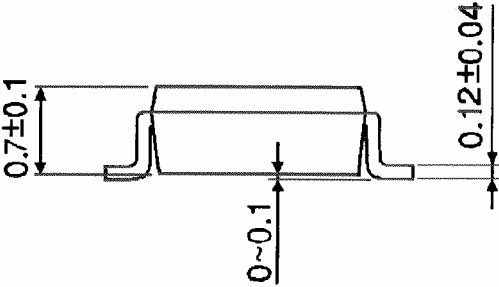
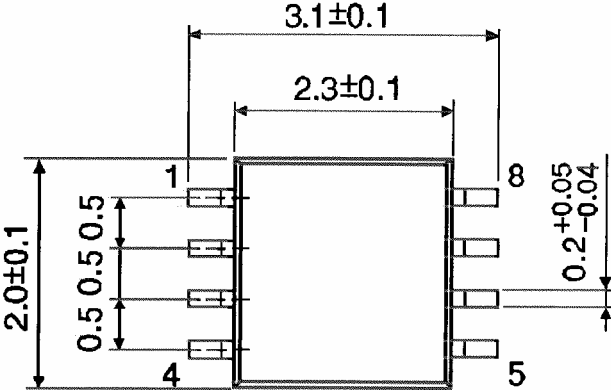

Weight: 0.01 g (typ.)

RESTRICTIONS ON PRODUCT USE

20070701-EN GENERAL

- The information contained herein is subject to change without notice.
- TOSHIBA is continually working to improve the quality and reliability of its products. Nevertheless, semiconductor devices in general can malfunction or fail due to their inherent electrical sensitivity and vulnerability to physical stress. It is the responsibility of the buyer, when utilizing TOSHIBA products, to comply with the standards of safety in making a safe design for the entire system, and to avoid situations in which a malfunction or failure of such TOSHIBA products could cause loss of human life, bodily injury or damage to property.
In developing your designs, please ensure that TOSHIBA products are used within specified operating ranges as set forth in the most recent TOSHIBA products specifications. Also, please keep in mind the precautions and conditions set forth in the "Handling Guide for Semiconductor Devices," or "TOSHIBA Semiconductor Reliability Handbook" etc.
- The TOSHIBA products listed in this document are intended for usage in general electronics applications (computer, personal equipment, office equipment, measuring equipment, industrial robotics, domestic appliances, etc.). These TOSHIBA products are neither intended nor warranted for usage in equipment that requires extraordinarily high quality and/or reliability or a malfunction or failure of which may cause loss of human life or bodily injury ("Unintended Usage"). Unintended Usage include atomic energy control instruments, airplane or spaceship instruments, transportation instruments, traffic signal instruments, combustion control instruments, medical instruments, all types of safety devices, etc.. Unintended Usage of TOSHIBA products listed in this document shall be made at the customer's own risk.
- The products described in this document shall not be used or embedded to any downstream products of which manufacture, use and/or sale are prohibited under any applicable laws and regulations.
- The information contained herein is presented only as a guide for the applications of our products. No responsibility is assumed by TOSHIBA for any infringements of patents or other rights of the third parties which may result from its use. No license is granted by implication or otherwise under any patents or other rights of TOSHIBA or the third parties.
- Please contact your sales representative for product-by-product details in this document regarding RoHS compatibility. Please use these products in this document in compliance with all applicable laws and regulations that regulate the inclusion or use of controlled substances. Toshiba assumes no liability for damage or losses occurring as a result of noncompliance with applicable laws and regulations.