

International IR Rectifier

25CTQ...SPbF 25CTQ.. -1PbF

SCHOTTKY RECTIFIER

30 Amp

$$I_{F(AV)} = 30\text{Amp}$$

$$V_R = 35/ 45\text{V}$$

Major Ratings and Characteristics



Characteristics	Values	Units
$I_{F(AV)}$ Rectangular waveform	30	A
V_{RRM} range	35/ 45	V
I_{FSM} @tp = 5 μ s sine	990	A
V_F @15 Apk, $T_J=125^\circ\text{C}$ (per leg)	0.50	V
T_J range	-55 to 150	$^\circ\text{C}$

Description/ Features

The 25CTQ.. center tap Schottky rectifier series has been optimized for very low forward voltage drop, with moderate leakage. The proprietary barrier technology allows for reliable operation up to 150° C junction temperature. Typical applications are in switching power supplies, converters, free-wheeling diodes, and reverse battery protection.

- 150° C T_J operation
- Center tap TO-220 package
- High purity, high temperature epoxy encapsulation for enhanced mechanical strength and moisture resistance
- Very low forward voltage drop
- High frequency operation
- Guard ring for enhanced ruggedness and long term reliability
- Lead-Free ("PbF" suffix)

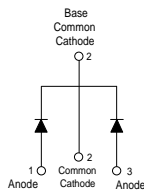
Case Styles

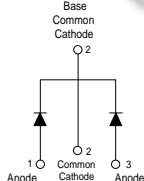
<p>25CTQ...SPbF</p>   <p>D²PAK</p>	<p>25CTQ...-1PbF</p>   <p>TO-262</p>
--	---

Voltage Ratings

Part number	25CTQ035SPbF 25CTQ035-1PbF	25CTQ040SPbF 25CTQ040-1PbF	25CTQ045SPbF 25CTQ045-1PbF
V_R Max. DC Reverse Voltage (V)	35	40	45
V_{RWM} Max. Working Peak Reverse Voltage (V)			

Absolute Maximum Ratings

Parameters	25CTQ	Units	Conditions
$I_{F(AV)}$ Max. Average Forward Current * See Fig. 5	30	A	50% duty cycle @ $T_C = 102^\circ\text{C}$, rectangular wave form
I_{FSM} Max. Peak One Cycle Non-Repetitive Surge Current (Per Leg) * See Fig. 7	990	A	5 μs Sine or 3 μs Rect. pulse 10ms Sine or 6ms Rect. pulse
	250		
E_{AS} Non-Repetitive Avalanche Energy (Per Leg)	20	mJ	$T_J = 25^\circ\text{C}$, $I_{AS} = 3\text{Amps}$, $L = 4.40\text{mH}$
I_{AR} Repetitive Avalanche Current (Per Leg)	3	A	Current decaying linearly to zero in 1 μsec Frequency limited by T_J max. $V_A = 1.5 \times V_R$ typical

Electrical Specifications

Parameters	25CTQ	Units	Conditions
V_{FM} Max. Forward Voltage Drop (Per Leg) * See Fig. 1 (1)	0.56	V	@ 15A
	0.71	V	@ 30A
	0.50	V	@ 15A
	0.64	V	@ 30A
I_{RM} Max. Reverse Leakage Current (Per Leg) * See Fig. 2 (1)	1.75	mA	$T_J = 25^\circ\text{C}$
	70	mA	$T_J = 125^\circ\text{C}$
C_T Max. Junction Capacitance (Per Leg)	900	pF	$V_R = 5V_{DC}$ (test signal range 100Khz to 1Mhz) 25°C
L_S Typical Series Inductance (Per Leg)	8.0	nH	Measured lead to lead 5mm from package body
dv/dt Max. Voltage Rate of Change	10000	V/ μs	(Rated V_R)

(1) Pulse Width < 300 μs , Duty Cycle <2%

Thermal-Mechanical Specifications

Parameters	25CTQ	Units	Conditions
T_J Max. Junction Temperature Range	-55 to 150	$^\circ\text{C}$	
T_{stg} Max. Storage Temperature Range	-55 to 150	$^\circ\text{C}$	
R_{thJC} Max. Thermal Resistance Junction to Case (Per Leg)	3.25	$^\circ\text{C/W}$	DC operation * See Fig. 4
R_{thJC} Max. Thermal Resistance Junction to Case (Per Package)	1.63	$^\circ\text{C/W}$	DC operation
R_{thCS} Typical Thermal Resistance, Case to Heatsink	0.50	$^\circ\text{C/W}$	Mounting surface, smooth and greased
wt Approximate Weight	2.0 (0.07)	g (oz.)	
T Mounting Torque	Min.	6 (5)	Kg-cm (lbf-in)
	Max.	12 (10)	
Marking Device	25CTQ...S	Case style D ² Pak	
	25CTQ...-1	Case style TO-262	

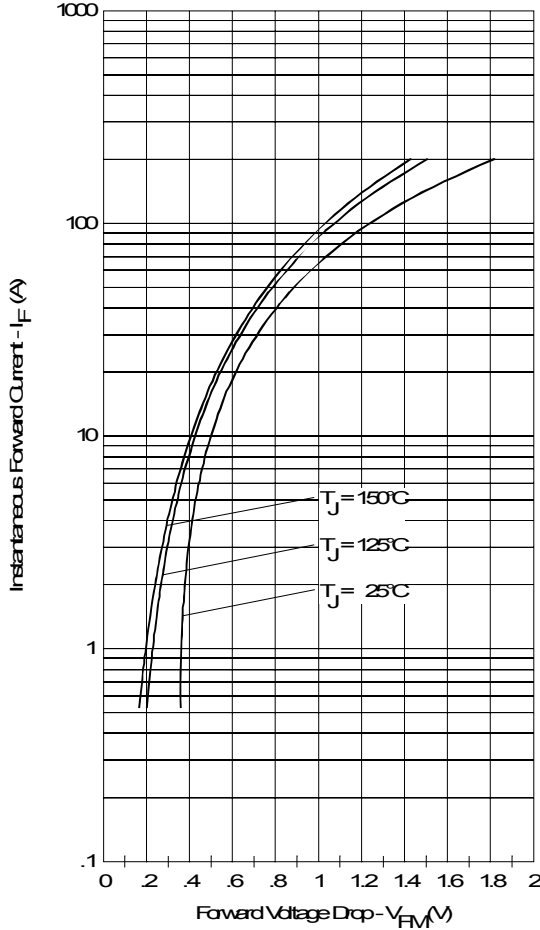

Fig. 1 - Max. Forward Voltage Drop Characteristics (Per Leg)

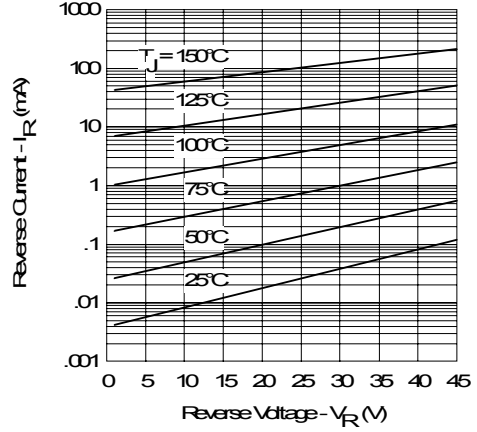

Fig. 2 - Typical Values Of Reverse Current Vs. Reverse Voltage (Per Leg)

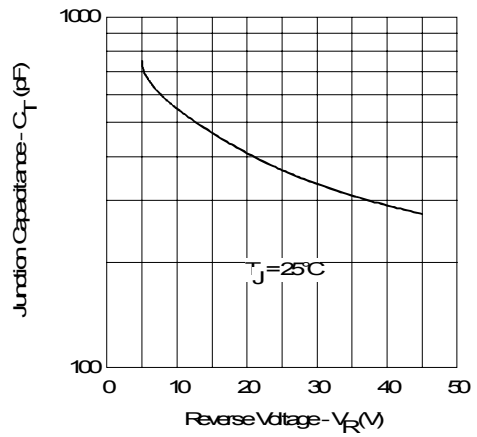

Fig. 3 - Typical Junction Capacitance Vs. Reverse Voltage (Per Leg)

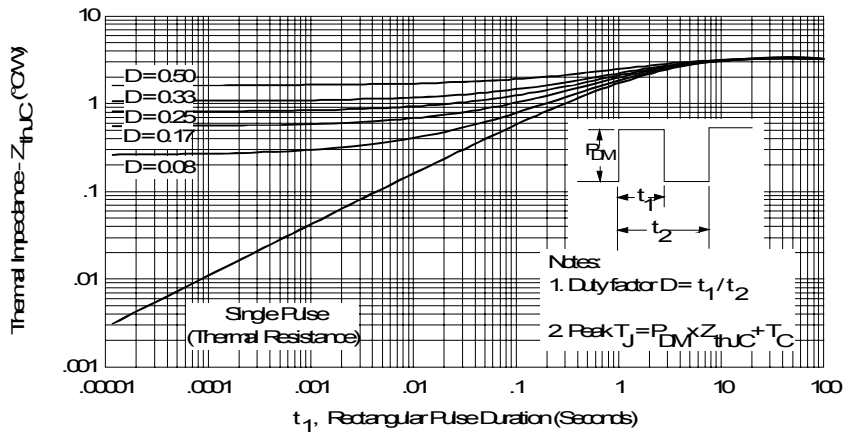

Fig. 4 - Max. Thermal Impedance Z_{thJC} Characteristics (Per Leg)

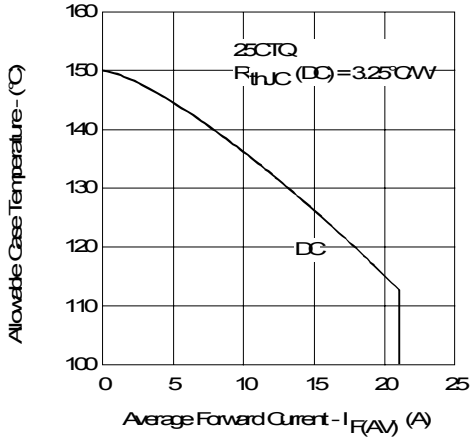

Fig. 5 - Max. Allowable Case Temperature Vs. Average Forward Current (Per Leg)

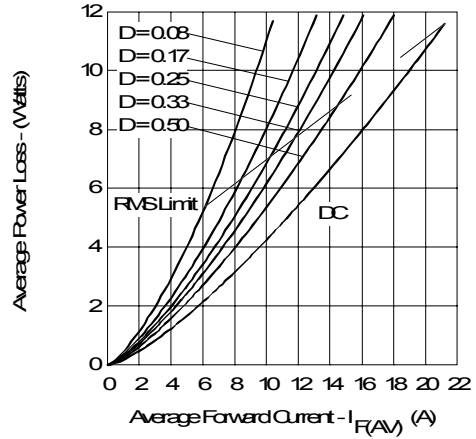

Fig. 6 - Forward Power Loss Characteristics (Per Leg)

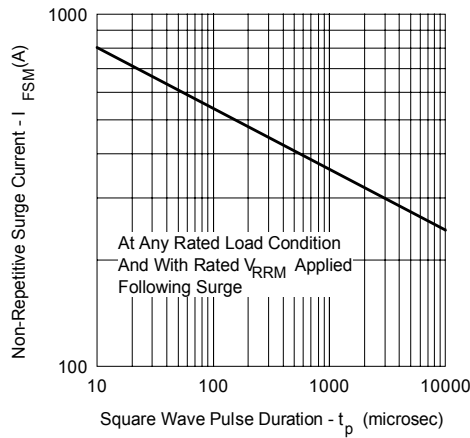

Fig. 7 - Max. Non-Repetitive Surge Current (Per Leg)

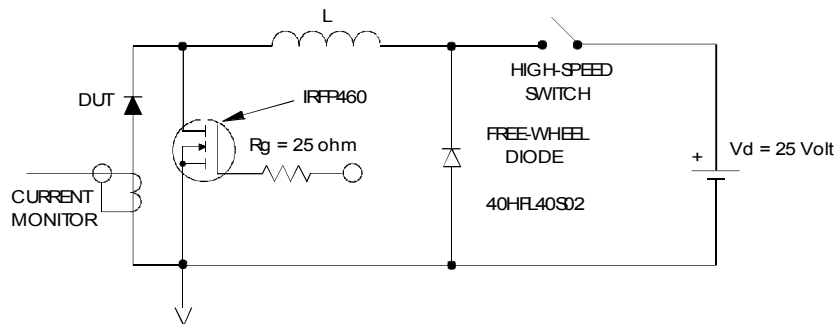
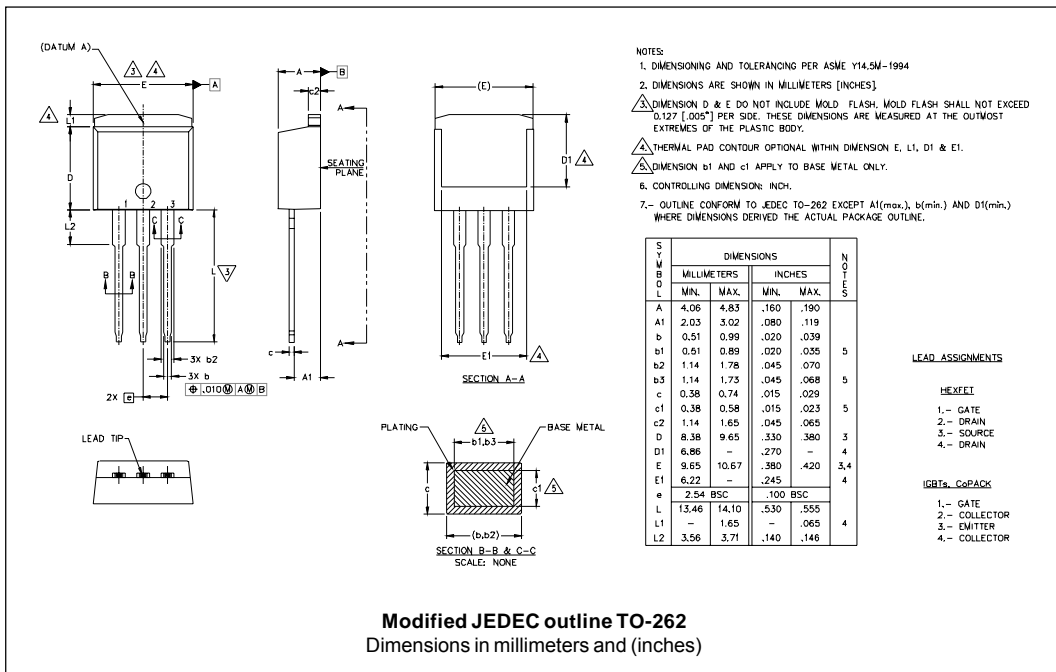
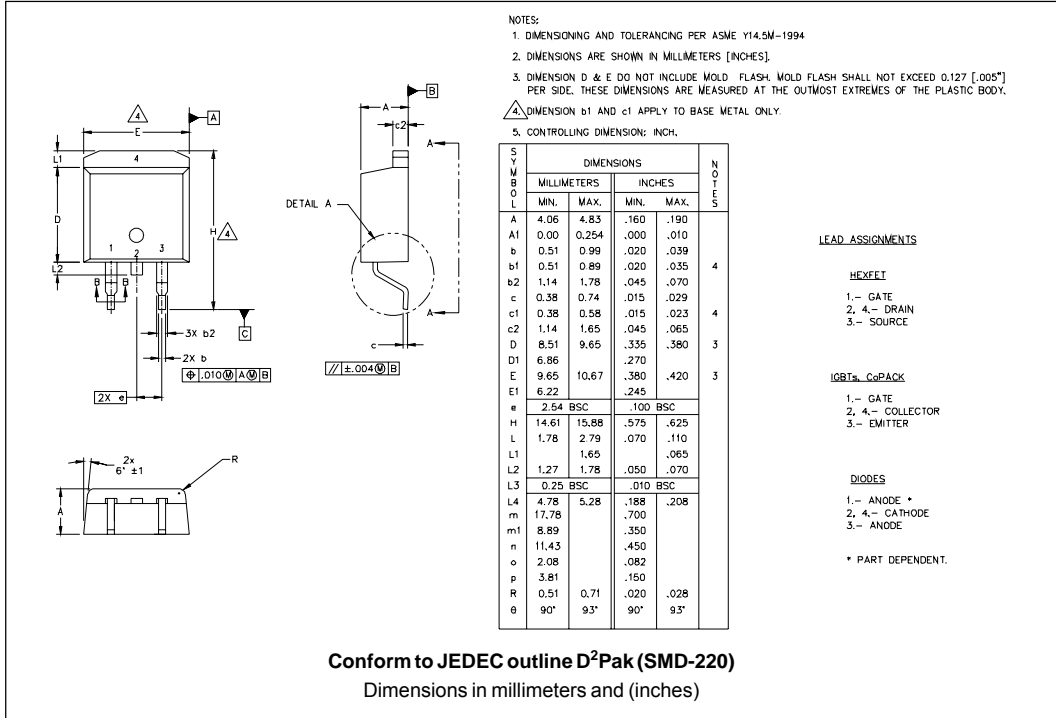

Fig. 8 - Unclamped Inductive Test Circuit

Outlines Table



Part Marking Information

D²PAK

EXAMPLE: THIS IS A 25CTQ045S
 LOT CODE 8024
 ASSEMBLED ON WW 02, 2000

Note: "P" in assembly line position indicates "Lead-Free"

INTERNATIONAL RECTIFIER LOGO

ASSEMBLY LOT CODE

PART NUMBER

DATE CODE

YEAR 0 = 2000
 WEEK 02
 P = LEAD-FREE

TO-262

EXAMPLE: THIS IS A 25CTQ045-1
 LOT CODE 1789
 ASSEMBLED ON WW 19, 2002

Note: "P" in assembly line position indicates "Lead-Free"

INTERNATIONAL RECTIFIER LOGO

ASSEMBLY LOT CODE

PART NUMBER

DATE CODE

YEAR 2 = 2002
 WEEK 19
 P = LEAD-FREE

Tape & Reel Information

SECTION Y-Y

NOTES:

- 1.0 10 SPROCKET HOLE PITH CUMULATIVE TOLERANCE ±0.2
- 2.0 CAMBER NOT TO EXCEED 1mm In 100mm
- 3.0 MATERIAL: CONDUCTIVE BLACK STYRENIC ALLOY
- 4.0 K₀ MEASURED FROM A PLANE ON THE INSIDE BOTTOM OF THE POCKET TO THE TOP SURFACE OF THE CARRIER
- 5.0 MEASURED FROM CENTRELINE OF SPROCKET HOLE TO CENTRELINE OF POCKET
- 6.0 VENDOR: (OPTIONAL)
- 7.0 MUST ALSO MEET REQUIREMENTS OF EIA STANDAR #EIA-481A TAPING OF SURFACE MOUNT COMPONENTS FOR AUTOMATIC PLACEMENT
- 8.0 SURFACE RESISTIVITY OF MOLDED MATL. MUST MEASURE LESS OR EQUAL TO 10⁶ OHMS PER SQUARE. MEASURED IN ACCORDANCE TO PROCEDURE GIVEN IN ASTM D-257 & ASTM D-991
- 9.0 TOTAL LENGTH PER REEL MUST BE 45 METERS
- 10.0 © CRITICAL

Ao	10.50	+/-	0.1
B0	15.80	+/-	0.1
B2	10.25	+/-	0.1
Ko	4.90	+/-	0.1
F	11.50	+/-	0.1
P1	16.00	+/-	0.1
W	24.00	+/-	0.3

Dimensions in millimeters and (inches)

Ordering Information Table

Device Code		25	C	T	Q	045	S	TRL	PbF
		①	②	③	④	⑤	⑥	⑦	⑧
1	-	Current Rating (25A)							
2	-	Circuit Configuration							
		C = Common Cathode							
3	-	T = TO-220							
4	-	Schottky "Q" Series							
5	-	Voltage Ratings							
6	-	<ul style="list-style-type: none"> • S = D²Pak • -1= TO-262 							
7	-	<ul style="list-style-type: none"> • none = Tube (50 pieces) • TRL = Tape & Reel (Left Oriented - for D²Pak only) • TRR = Tape & Reel (Right Oriented - for D²Pak only) 							
8	-	<ul style="list-style-type: none"> • none = Standard Production • PbF = Lead-Free 							

```

25CTQ045
*****
* This model has been developed by *
* Wizard SPICE MODEL GENERATOR (1999) *
* (International Rectifier Corporation) *
* Contain Proprietary Information *
*****
* SPICE Model Diode is composed by a *
* simple diode plus paralalled VCG2T *
*****
.SUBCKT 25CTQ045 ANO CAT
D1 ANO 1 DMOD (0.07089)
*Define diode model
.MODEL DMOD D(IS=1.72789623043916E-04A,N=1.16449261507669,BV=52V,
+ IBV=0.347382965330896A,RS= 0.000623832,CJO=2.01681525450576E-08,
+ VJ=1.79426113441105,XTI=2, EG=0.778356513713514)
*****
*Implementation of VCG2T
VX 1 2 DC 0V
R1 2 CAT TRES 1E-6
.MODEL TRES RES(R=1,TC1=30.866905105089)
GP1 ANO CAT VALUE={-ABS(I(VX))*(EXP(((((-2.873853E-03/30.86691)*((V(2,CAT)*1E6)/(I(VX)+1E-6)-
1))+1)*5.486216E-02*ABS(V(ANO,CAT)))-1)}
*****
.ENDS 25CTQ045

Thermal Model Subcircuit
.SUBCKT 25CTQ045 5 1

CTHERM1 5 4 4.04E-01
CTHERM2 4 3 2.01E+00
CTHERM3 3 2 8.32E+00
CTHERM4 2 1 3.80E+02

R THERM1 5 4 1.62E+00
R THERM2 4 3 1.22E+00
R THERM1 3 2 3.50E-01
R THERM1 2 1 4.34E-02

.ENDS 25CTQ045
    
```

Data and specifications subject to change without notice.
 This product has been designed and qualified for Industrial Level and Lead-Free.
 Qualification Standards can be found on IR's Web site.