

HCD-V818

SERVICE MANUAL

E Model



HCD-V818 is the tuner, deck, Video CD and amplifier section in MHC-V818.

This stereo system is equipped with the Dolby B-type noise reduction system*.

* Manufactured under license from Dolby Laboratories Licensing Corporation.

DOLBY and the double-D symbol DD are trademarks of Dolby Laboratories Licensing Corporation.

CD SECTION	Model Name Using Similar Mechanism	HCD-V800
	CD Mechanism Type	CDM38L-5BD24AL
	Base Unit Type	BU-5BD24AL
	Optical Pick-up Type	KSS-213D/Q-NP
TAPE DECK SECTION	Model Name Using Similar Mechanism	HCD-GRX8/R800/RX88/RX99
	Tape Transport Mechanism Type	TCM-230AWR1 TCM-230PWR1

SPECIFICATIONS

Amplifier section

The following measured at AC 120, 220, 240 V 50/60Hz

DIN power output (rated)

105 + 105 watts
(8 ohms at 1 kHz, DIN)

Continuous RMS power output (reference)

130 + 130 watts
(8 ohms at 1 kHz, 10% THD)

Peak music power output (reference)

2000 watts

Inputs

VIDEO (AUDIO) IN (phono jacks):

voltage 250 mV,
impedance 47 kilohms

MD IN (phono jacks):

voltage 450 mV,
impedance 47 kilohms

MIC 1/2 (phone jack):

sensitivity 1 mV,
impedance 10 kilohms

Outputs

MD OUT (phono jacks):

voltage 250 mV
impedance 1 kilohms

VIDEO OUT (phono jack):

max. output level
1Vp-p, unbalanced,
Sync negative, load
impedance 75 ohms

S-VIDEO OUT (4-pin/mini-DIN jack):

Y: 1Vp-p, unbalanced,
Sync negative,
C: 0.286Vp-p,
load impedance 75 ohms

PHONES (stereo phone jack):

accepts headphones of 8 ohms or more

SPEAKER:

accepts impedance of 8 to 16 ohms

SURROUND SPEAKER:

accepts impedance of 16 ohms

SUPER WOOFER:

Voltage 1 V, impedance 1 kilohm

VIDEO CD/CD player section

System

Compact disc and digital audio and video system

Laser

Semiconductor laser
($\lambda=780\text{nm}$)

Emission duration:
continuous

Max. 44.6 μW^*

Laser output

*This output is the value measured at a distance of 200 mm from the objective lens surface on the Optical Pick-up Block with 7 mm aperture.

Wavelength

780 - 790 nm

Frequency response

2 Hz - 20 kHz (± 0.5 dB)

Signal-to-noise ratio

More than 90 dB

Dynamic range

More than 90 dB

Video

Color system format

NTSC, PAL

CD OPTICAL DIGITAL OUT

(Square optical connector jack, rear panel)

Wavelength

600 nm

Output Level

-18 dBm

Tape player section

Recording system

4-track 2-channel stereo

Frequency response

40 - 13,000 Hz (± 3 dB),

(DOLBY NR OFF)

using Sony TYPE I

cassette

40 - 14,000 Hz (± 3 dB),

using Sony TYPE II

cassette

Tuner section

FM stereo, FM / AM superheterodyne tuner

— Continued on next page —

COMPACT DISC DECK RECEIVER



SONY®

8-3. SCHEMATIC DIAGRAM – CD SECTION –

- See page 35 for Waveforms.
- See page 85 for IC Block Diagrams.

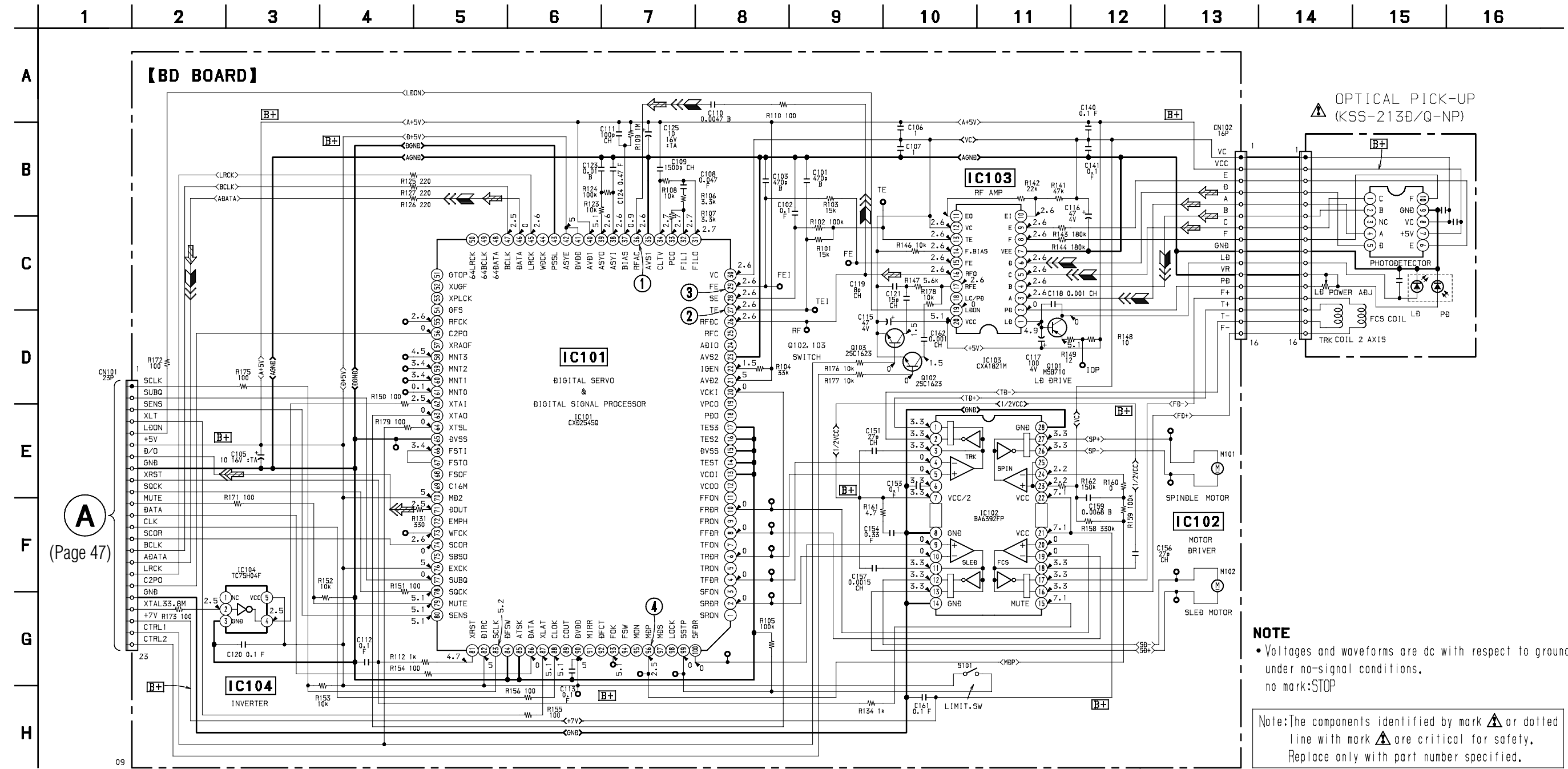

(Page 47)

8-5. SCHEMATIC DIAGRAM – DECK SECTION –
• See page 86 for IC Block Diagrams.

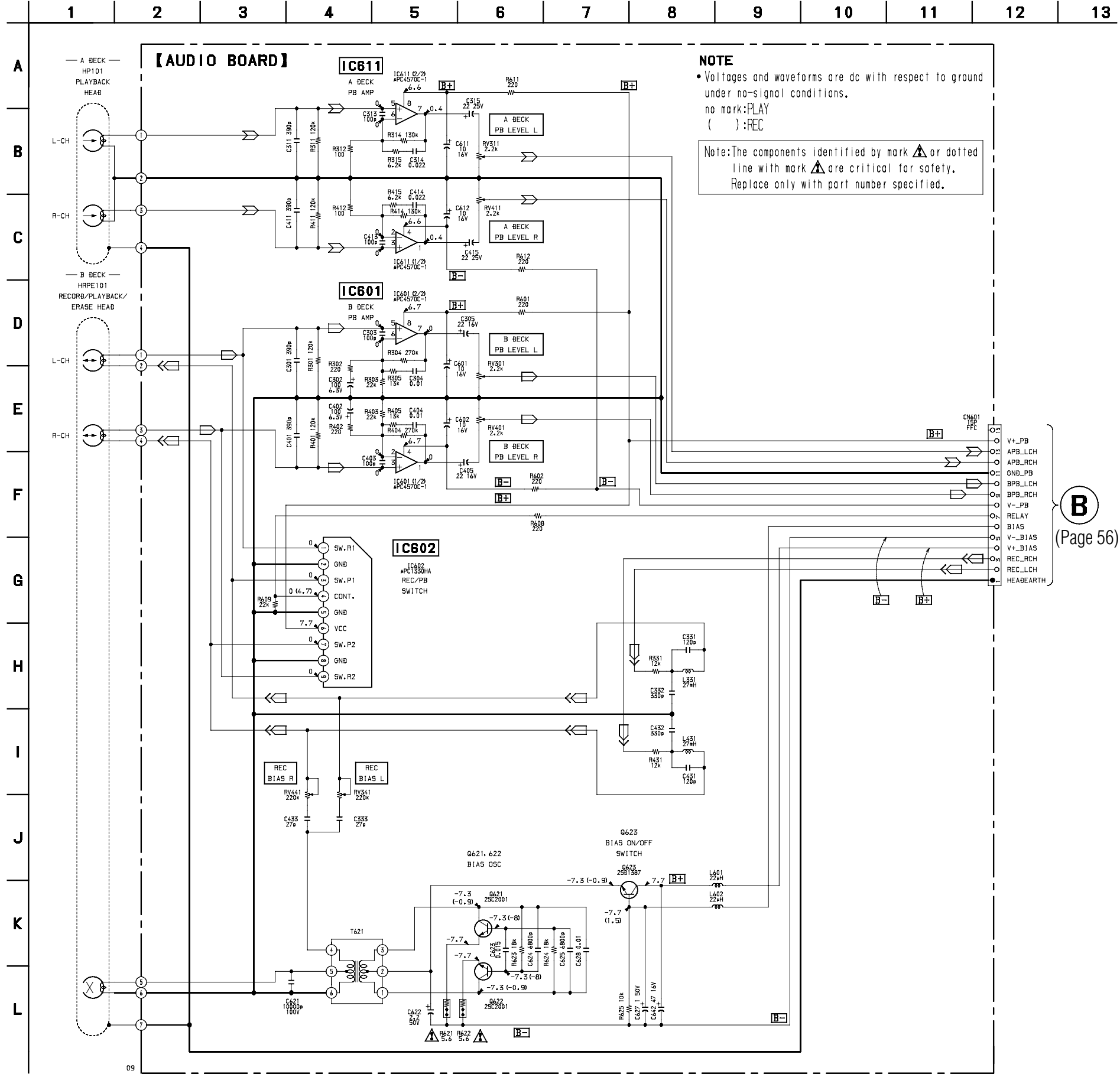

8-8. SCHEMATIC DIAGRAM – VIDEO (1/3) SECTION –

- See page 36 for Waveforms.
- See page 89 for IC Pin Functions.

* Note
When replacing IC502, refer to "IC502 of video Board" in "Service Note" (page 13).

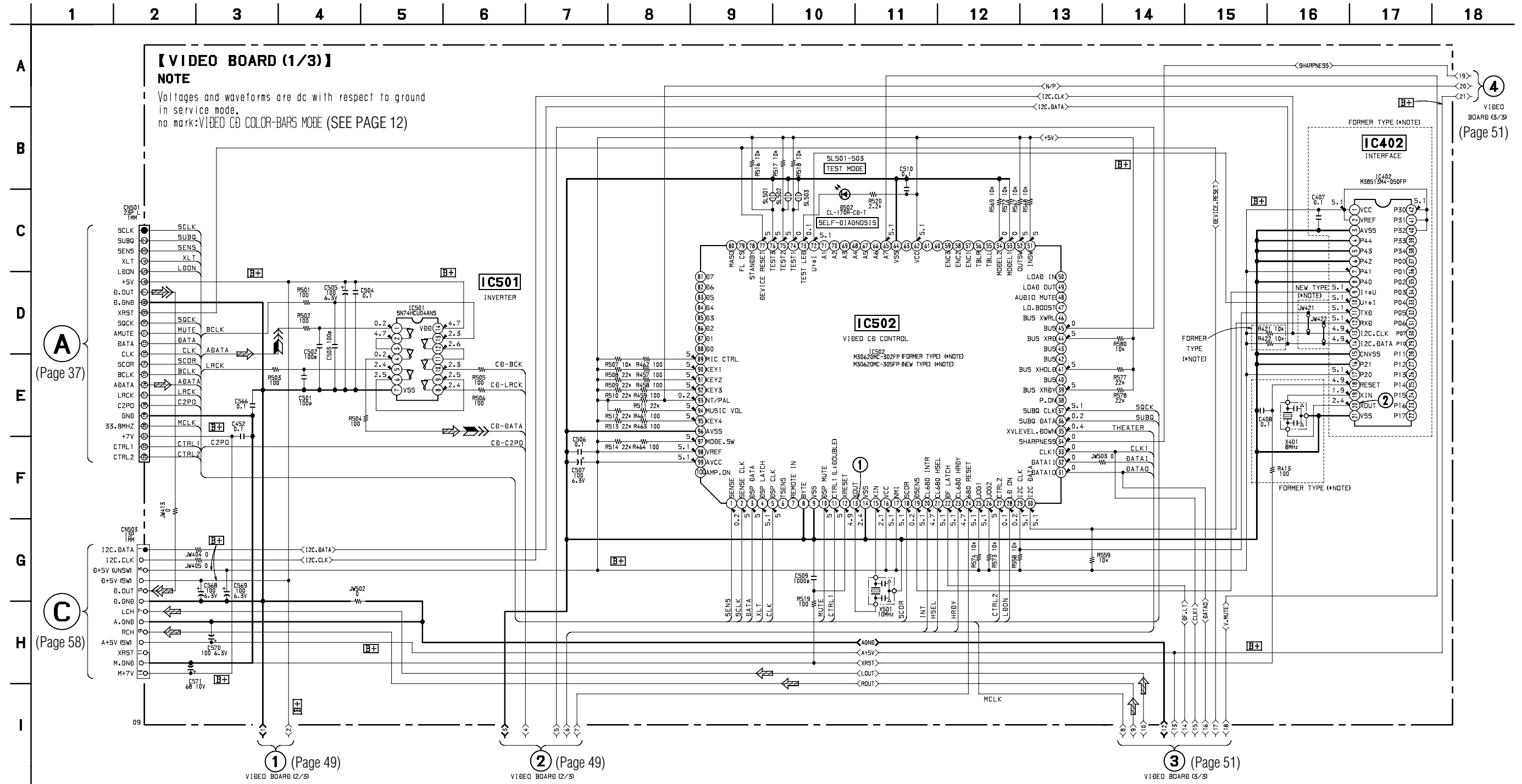

8-9. SCHEMATIC DIAGRAM – VIDEO (2/3) SECTION –

- See page 36 for Waveforms.
- See page 45 for Printed Wiring Board.
- See page 94 for IC Pin Functions.

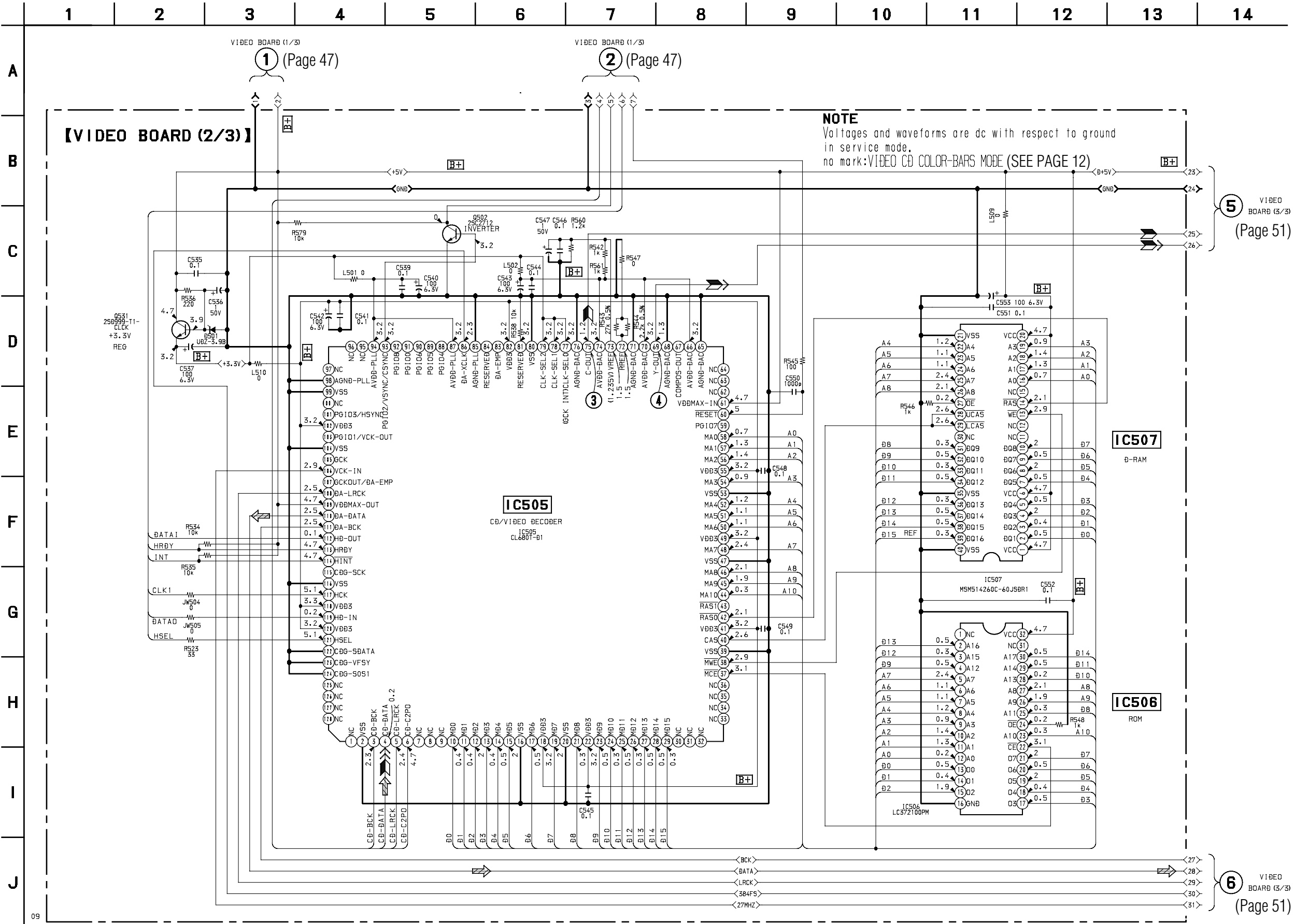

NOTE
 Voltages and waveforms are dc with respect to ground in service mode.
 no mark: VIDEO CB COLOR-BARS MODE (SEE PAGE 12)

5 VIDEO BOARD (3/3) (Page 51)

6 VIDEO BOARD (3/3) (Page 51)

8-10. SCHEMATIC DIAGRAM – VIDEO (3/3) SECTION –

- See page 36 for Waveforms.
- See page 45 for Printed Wiring Board.

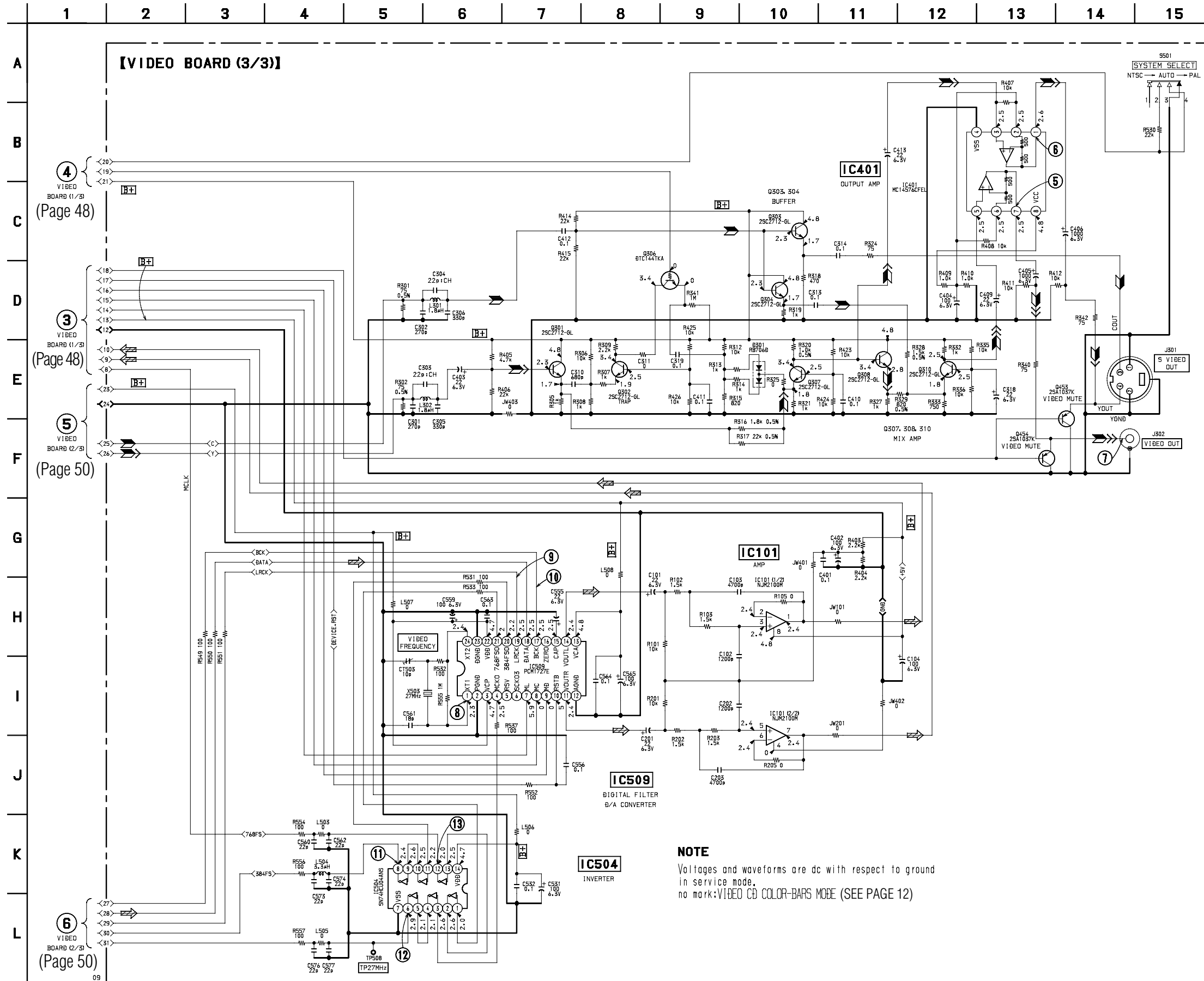

8-12. SCHEMATIC DIAGRAM – MAIN (1/4) SECTION –

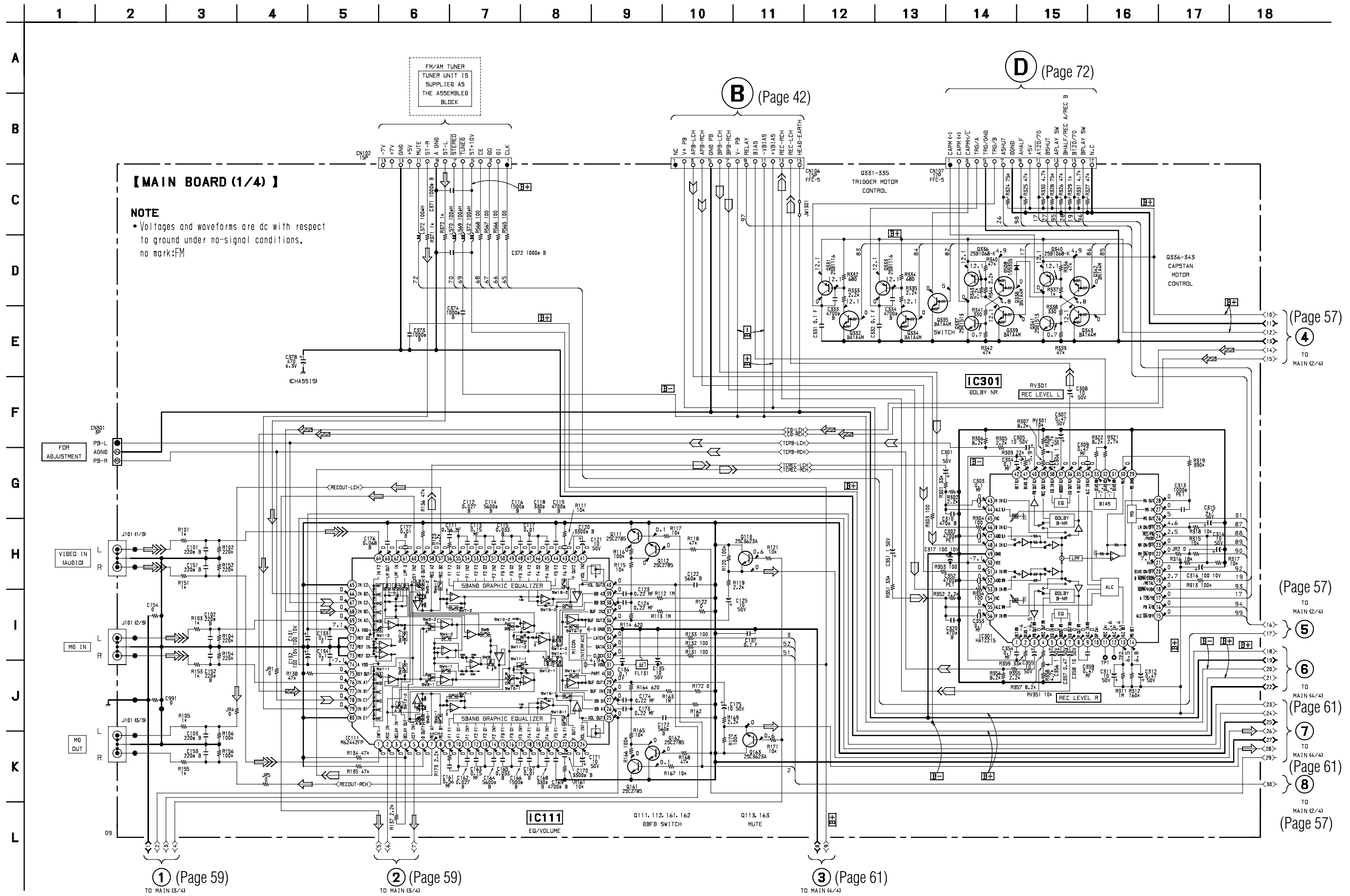

8-13. SCHEMATIC DIAGRAM – MAIN (2/4) SECTION –

- See page 36 for Waveforms.
- See page 53 for Printed Wiring Board.
- See page 89 for IC Pin Functions.

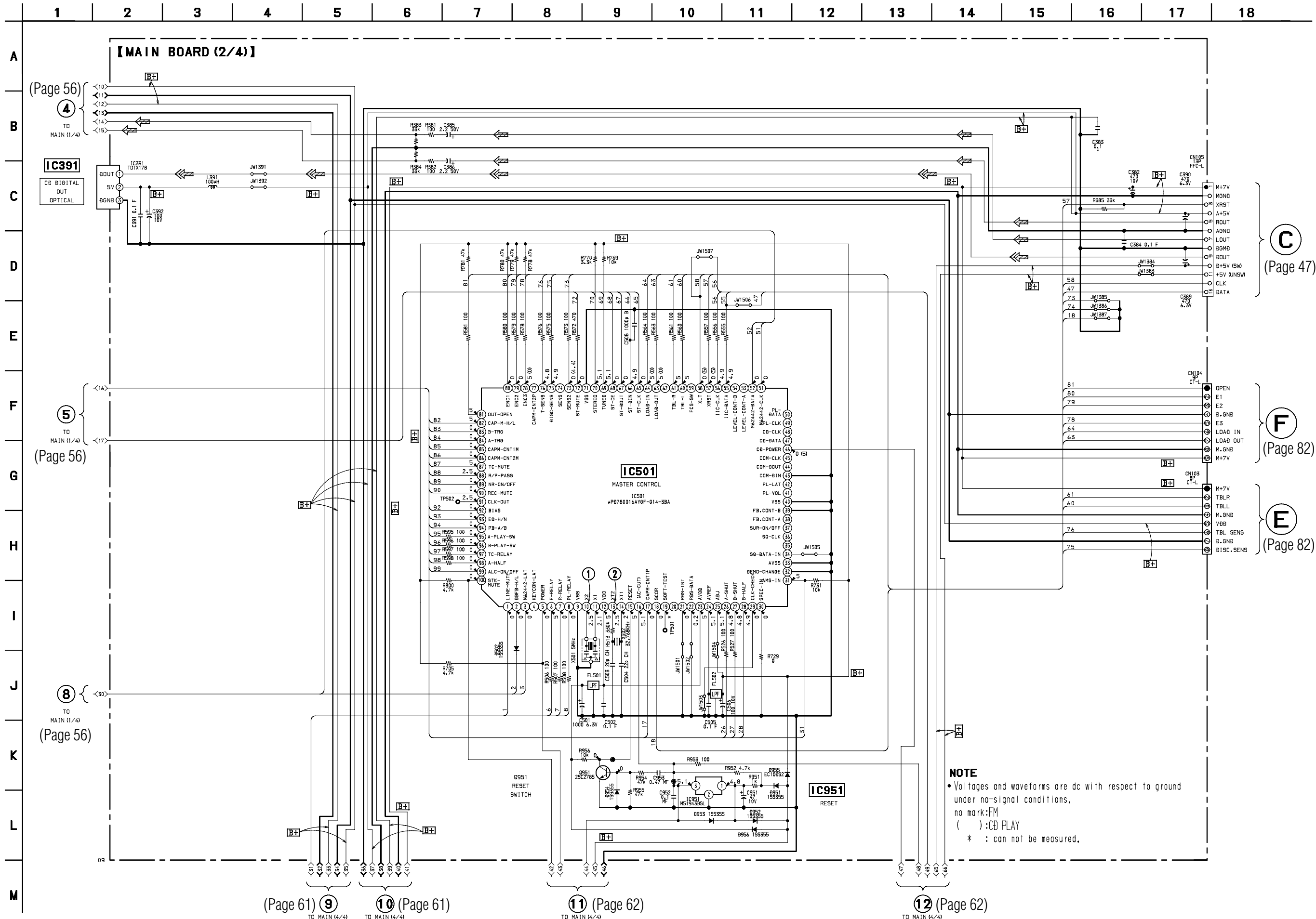

8-14. SCHEMATIC DIAGRAM – MAIN (3/4) SECTION –
 • See page 53 for Printed Wiring Board.

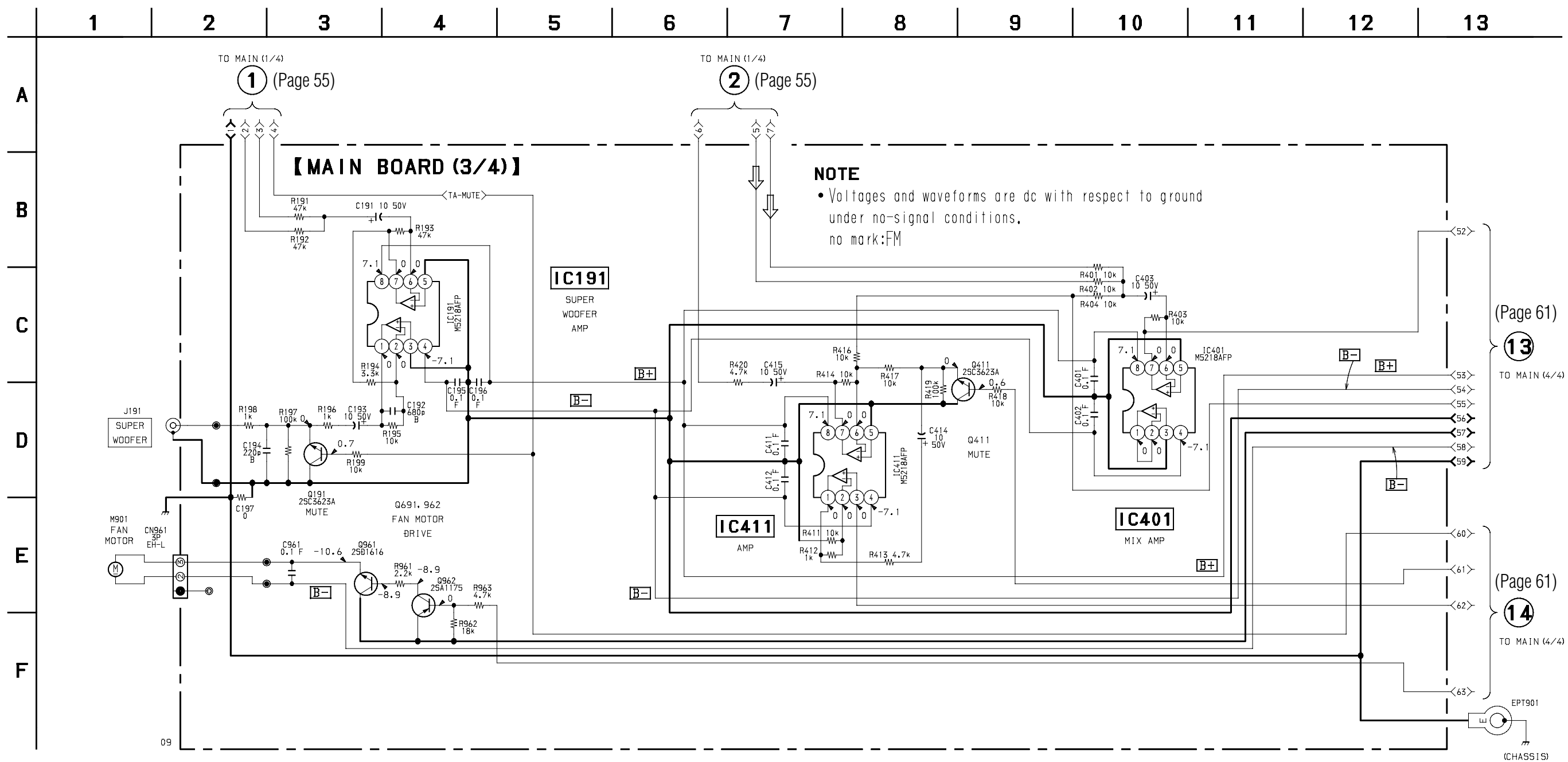

8-15. SCHEMATIC DIAGRAM – MAIN (4/4) SECTION –
• See page 53 for Printed Wiring Board.

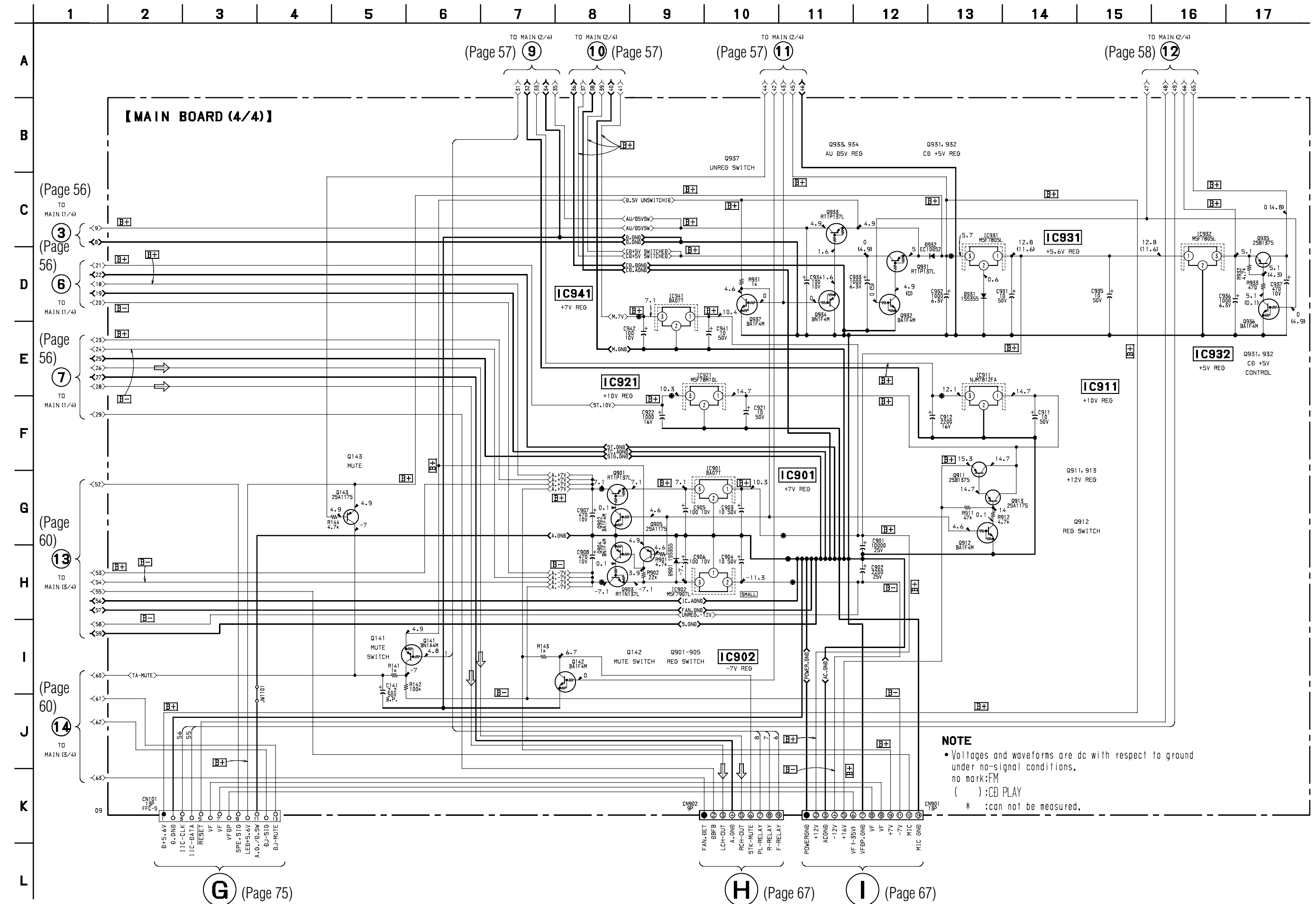

8-16. SCHEMATIC DIAGRAM – MIC/HP SECTION –
• See page 86 for IC Block Diagrams.

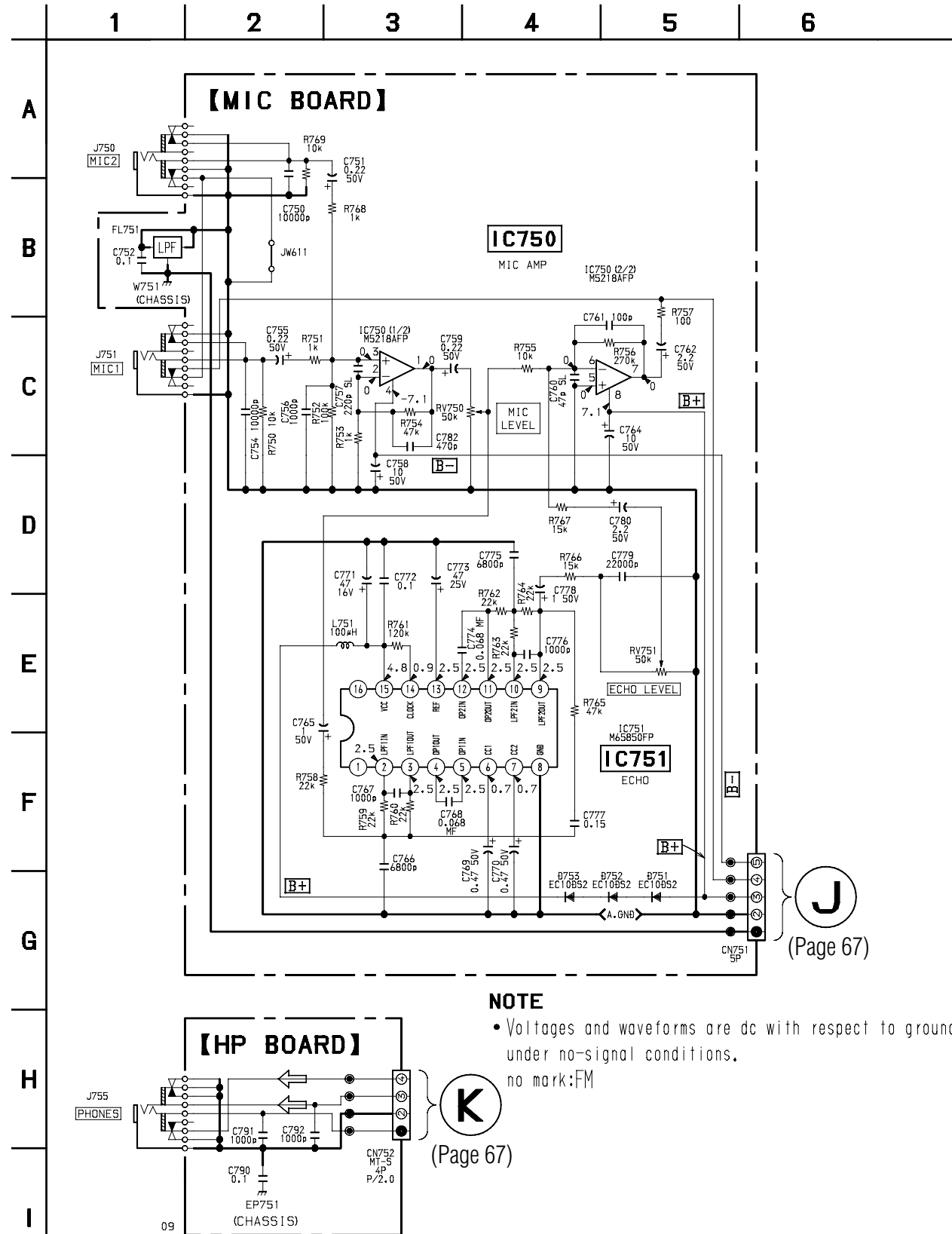

8-17. PRINTED WIRING BOARD – MIC/HP SECTION –
• See page 22 for Circuit Boards Location.

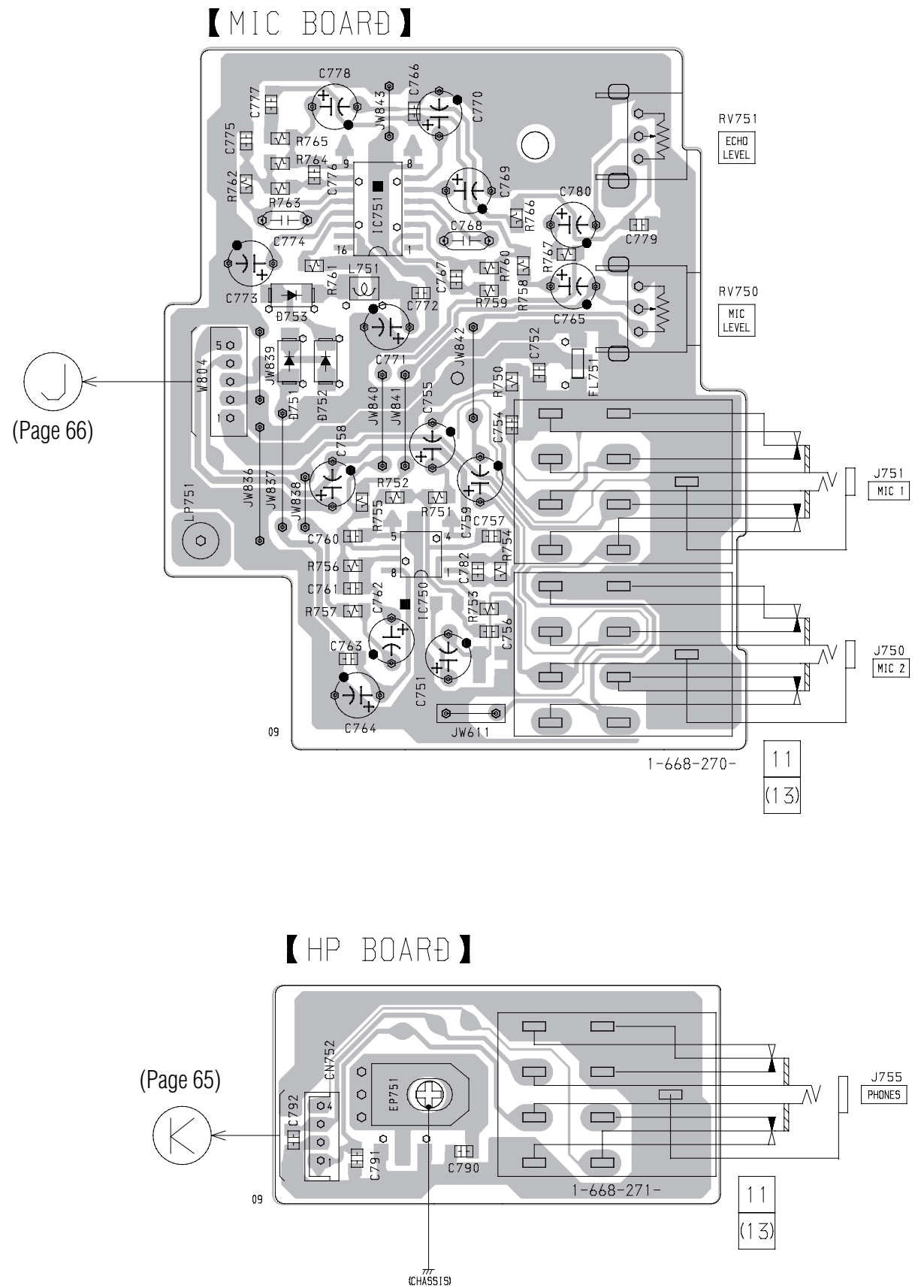

8-19. SCHEMATIC DIAGRAM – POWER AMP SECTION –

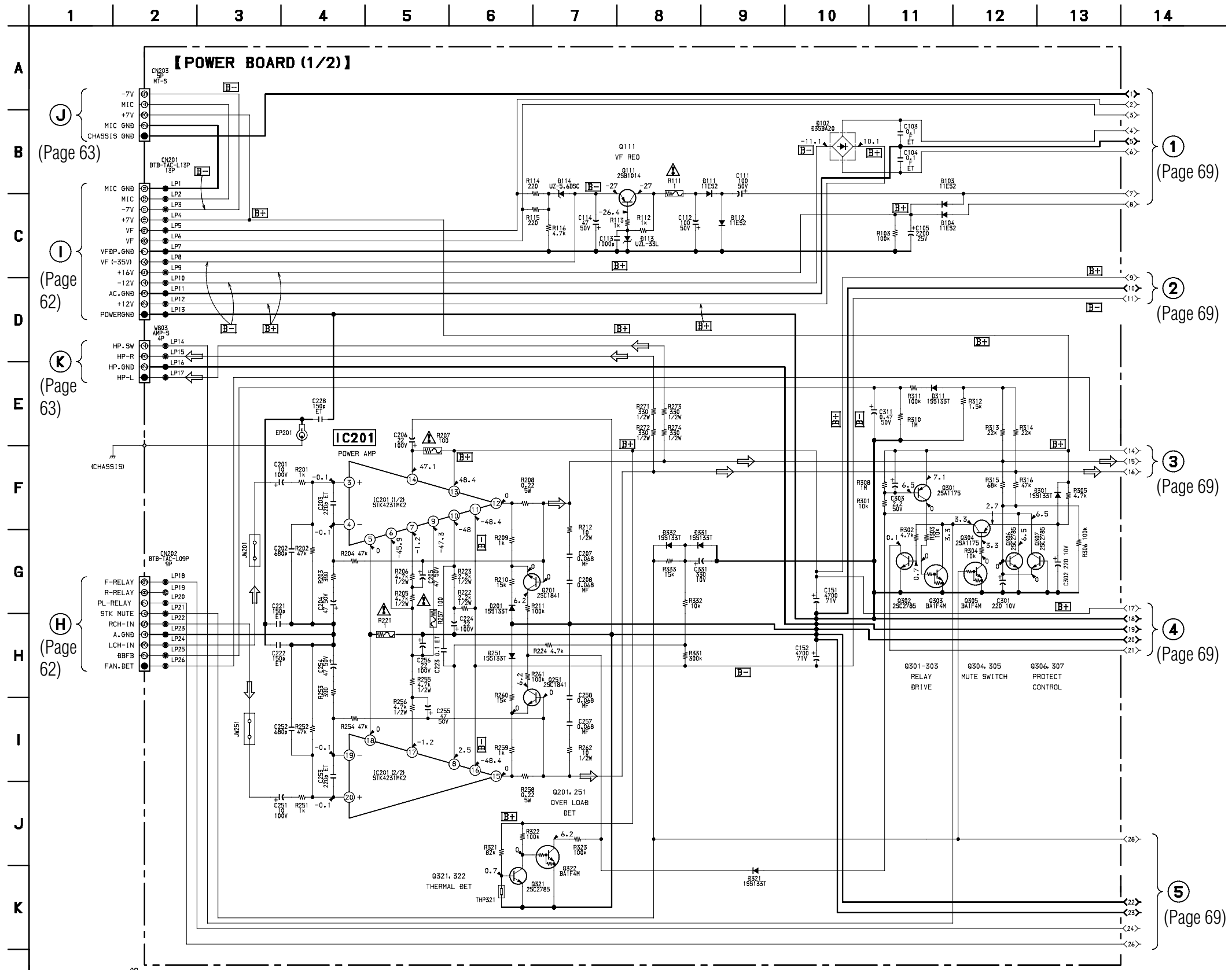

Note: The components identified by mark or dotted line with mark are critical for safety. Replace only with part number specified.

NOTE
 • Voltages and waveforms are dc with respect to ground under no-signal conditions, no mark:FM

① (Page 69)
 ② (Page 69)
 ③ (Page 69)
 ④ (Page 69)
 ⑤ (Page 69)

8-20. SCHEMATIC DIAGRAM – TRANSFORMER SECTION –
 • See page 65 for Printed Wiring Board. (POWER BOARD)

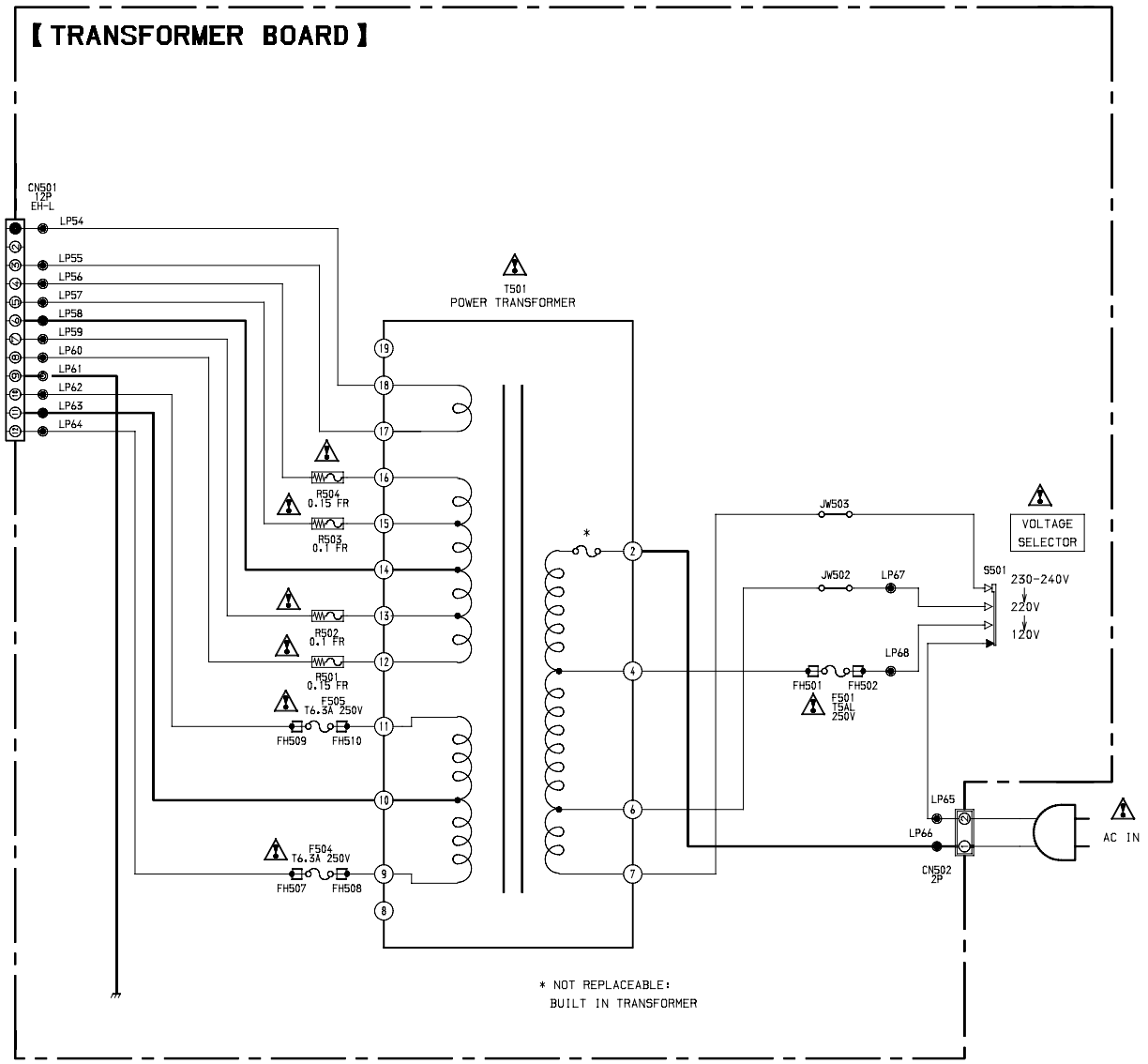
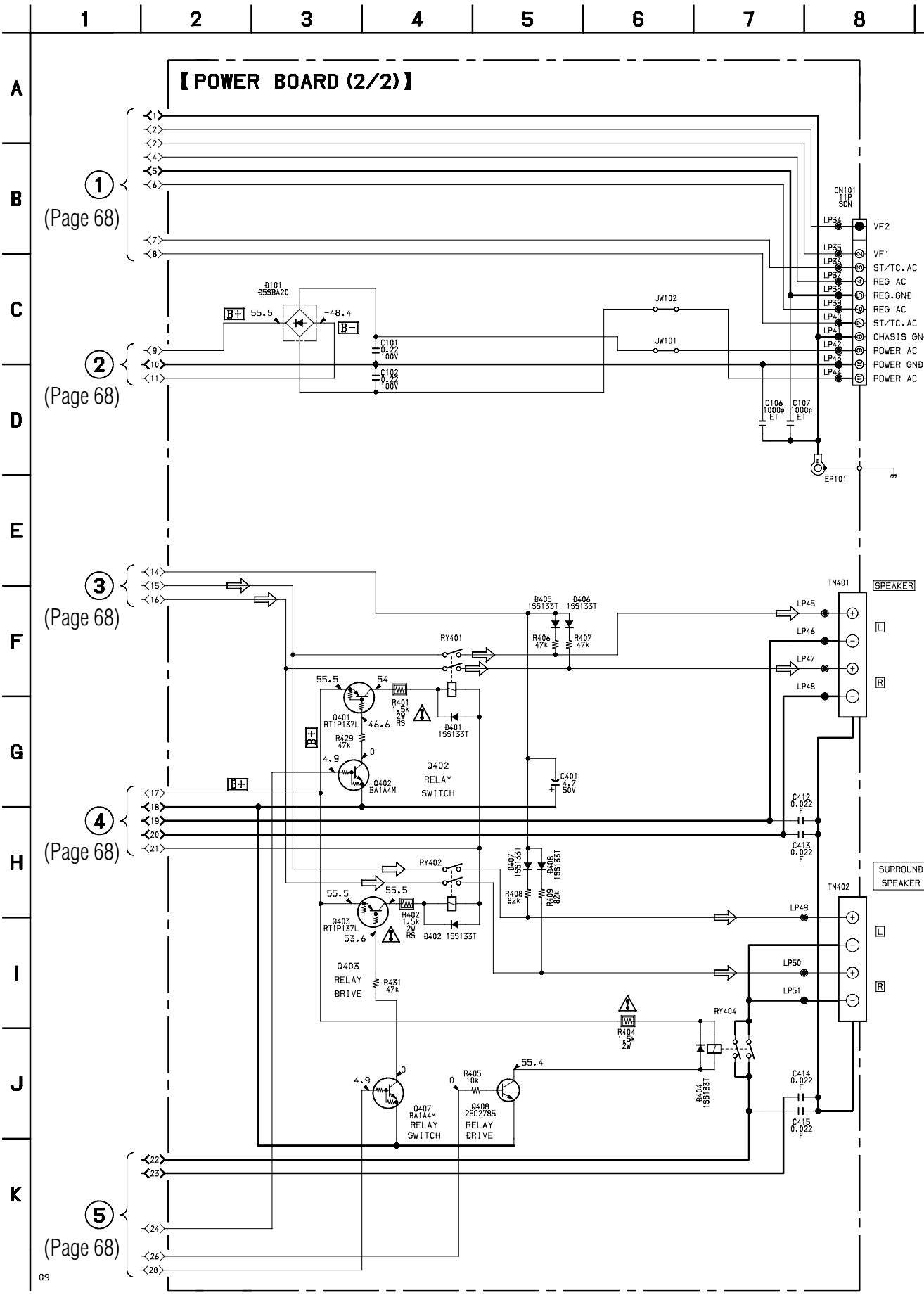

NOTE
 • Voltages and waveforms are dc with respect to ground under no-signal conditions.
 no mark:FM

Note: The components identified by mark or dotted line with mark are critical for safety. Replace only with part number specified.

8-21. PRINTED WIRING BOARD – TRANSFORMER SECTION –
 • See page 22 for Circuit Boards Location.

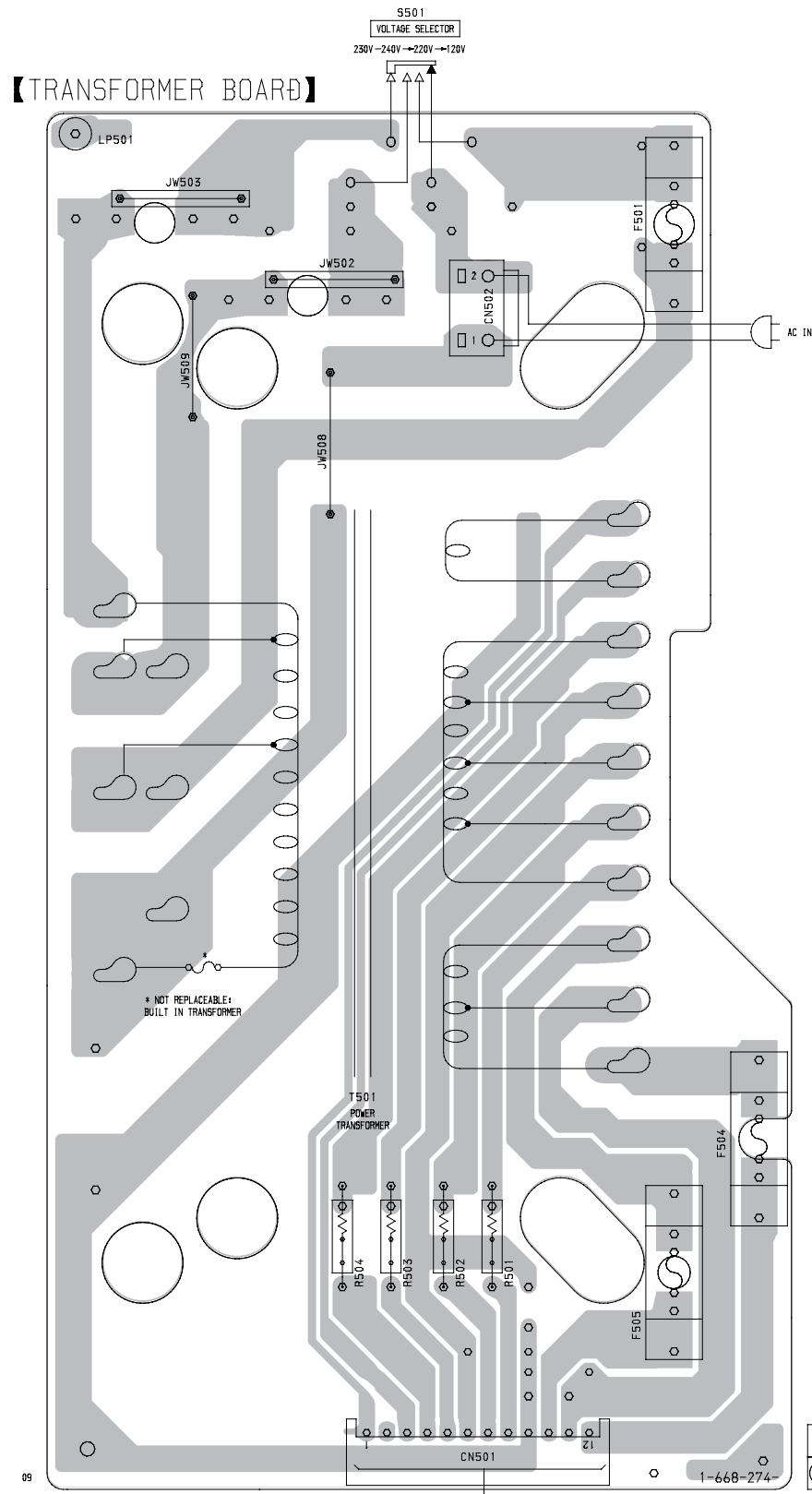

(Page 66)

8-22. PRINTED WIRING BOARD – LEAF SW SECTION –
 • See page 22 for Circuit Boards Location.

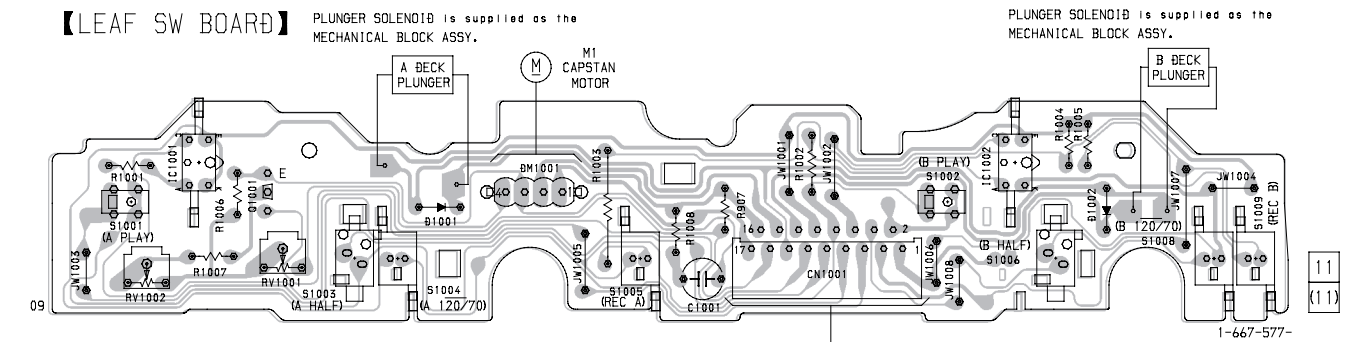

(Page 53)

8-23. SCHEMATIC DIAGRAM – LEAF SW SECTION –

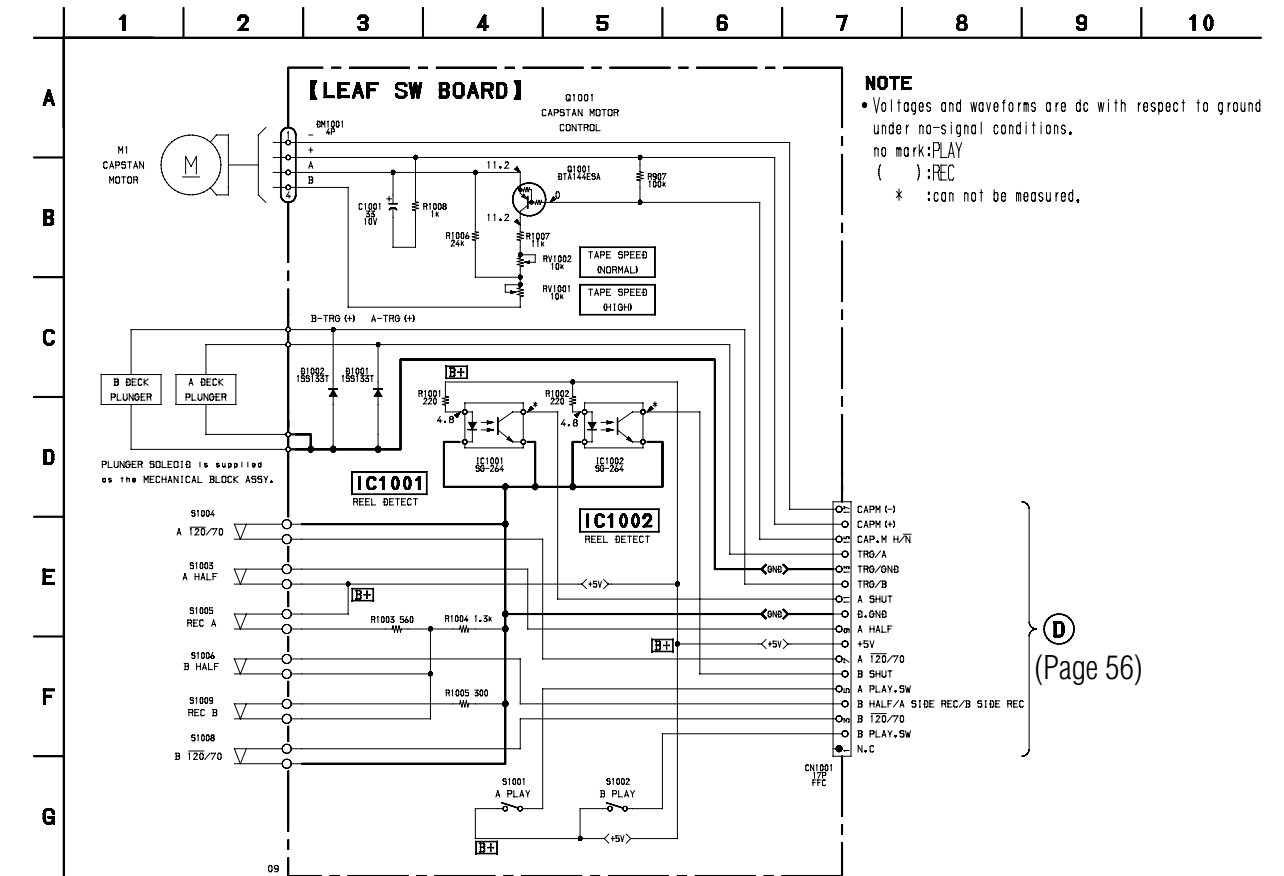

(Page 56)

8-25. SCHEMATIC DIAGRAM – DISPLAY SECTION –

- See page 36 for Waveforms.
- See page 86 for IC Block Diagrams.
- See page 97 for IC Pin Functions.

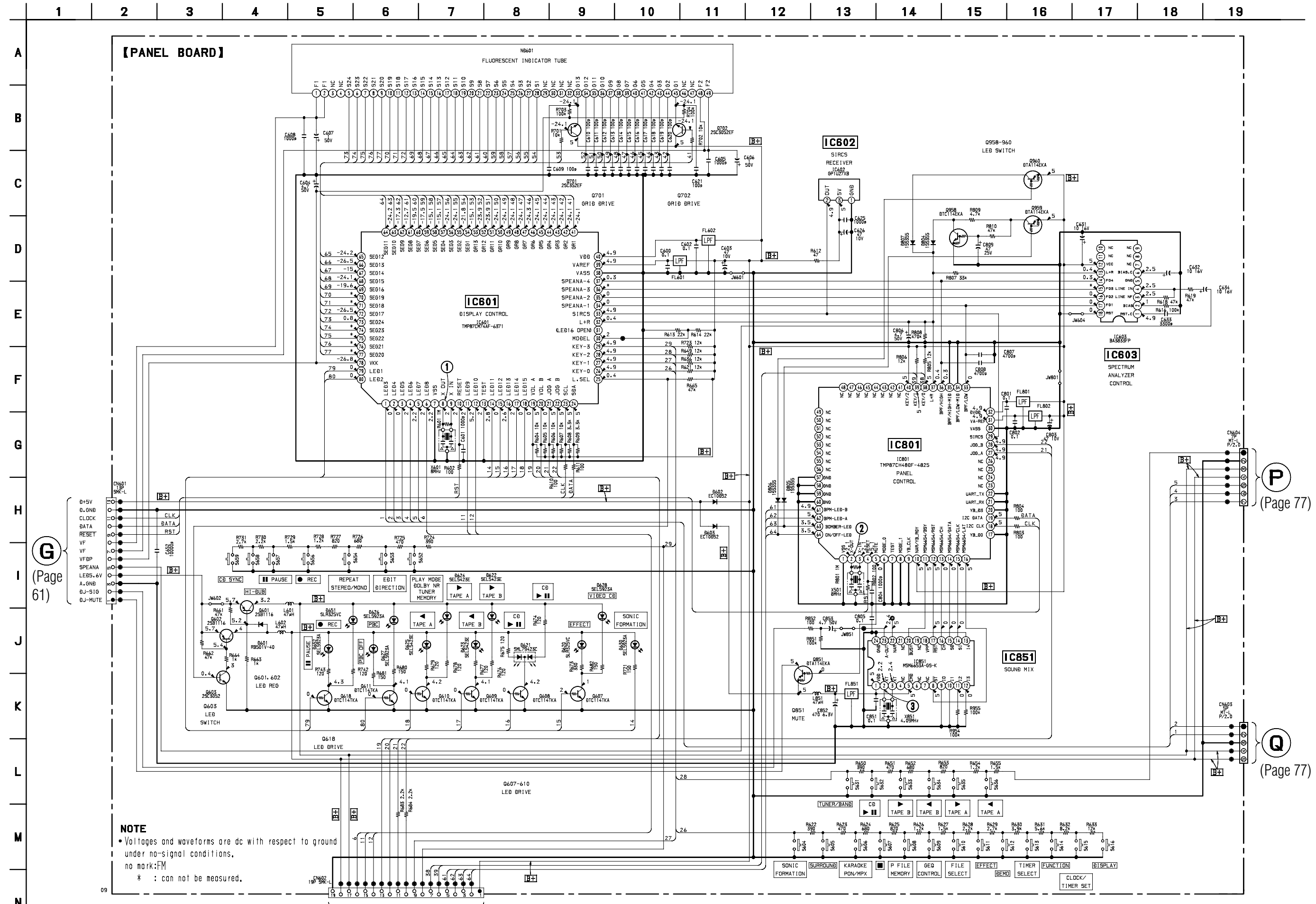

G (Page 61)

P (Page 77)

Q (Page 77)

O (Page 78)

8-26. SCHEMATIC DIAGRAM - PANEL SECTION -

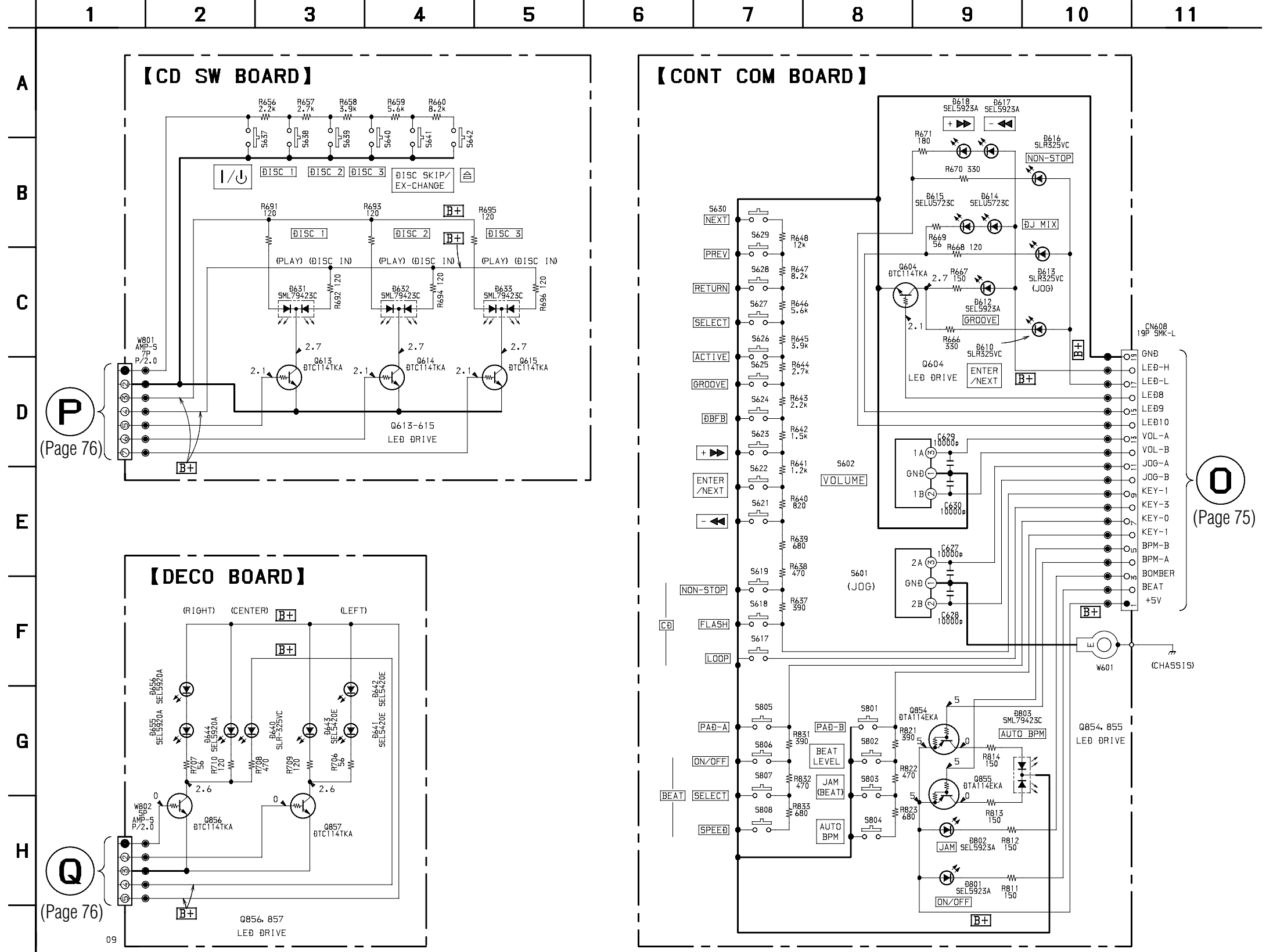

NOTE

- Voltages and waveforms are dc with respect to ground under no-signal conditions.
- no mark:FM

8-28. SCHEMATIC DIAGRAM – CD MOTOR SECTION –
 • See page 86 for IC Block Diagrams.

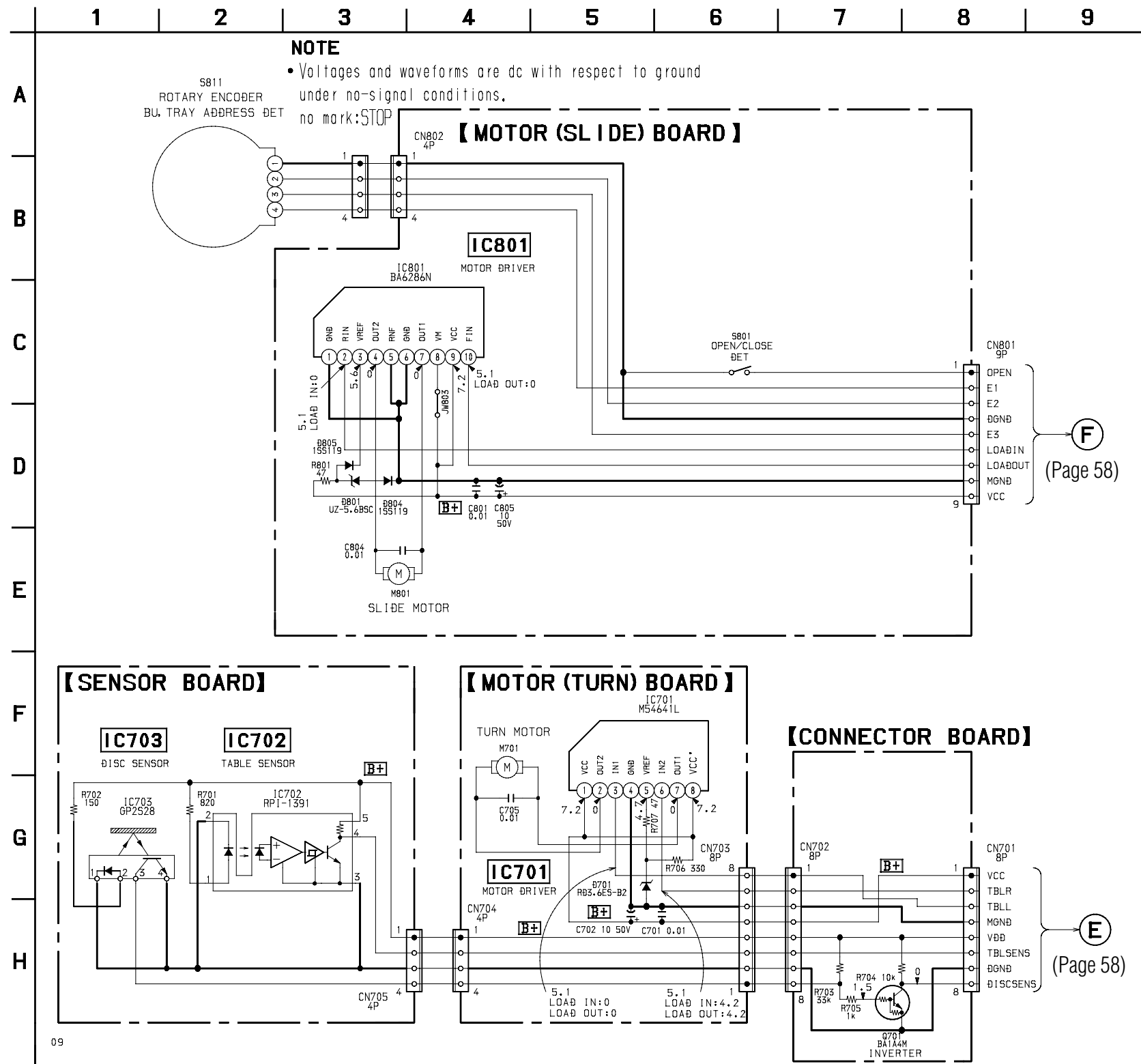

8-30. IC BLOCK DIAGRAMS

• CD section

IC101 CXD2545Q

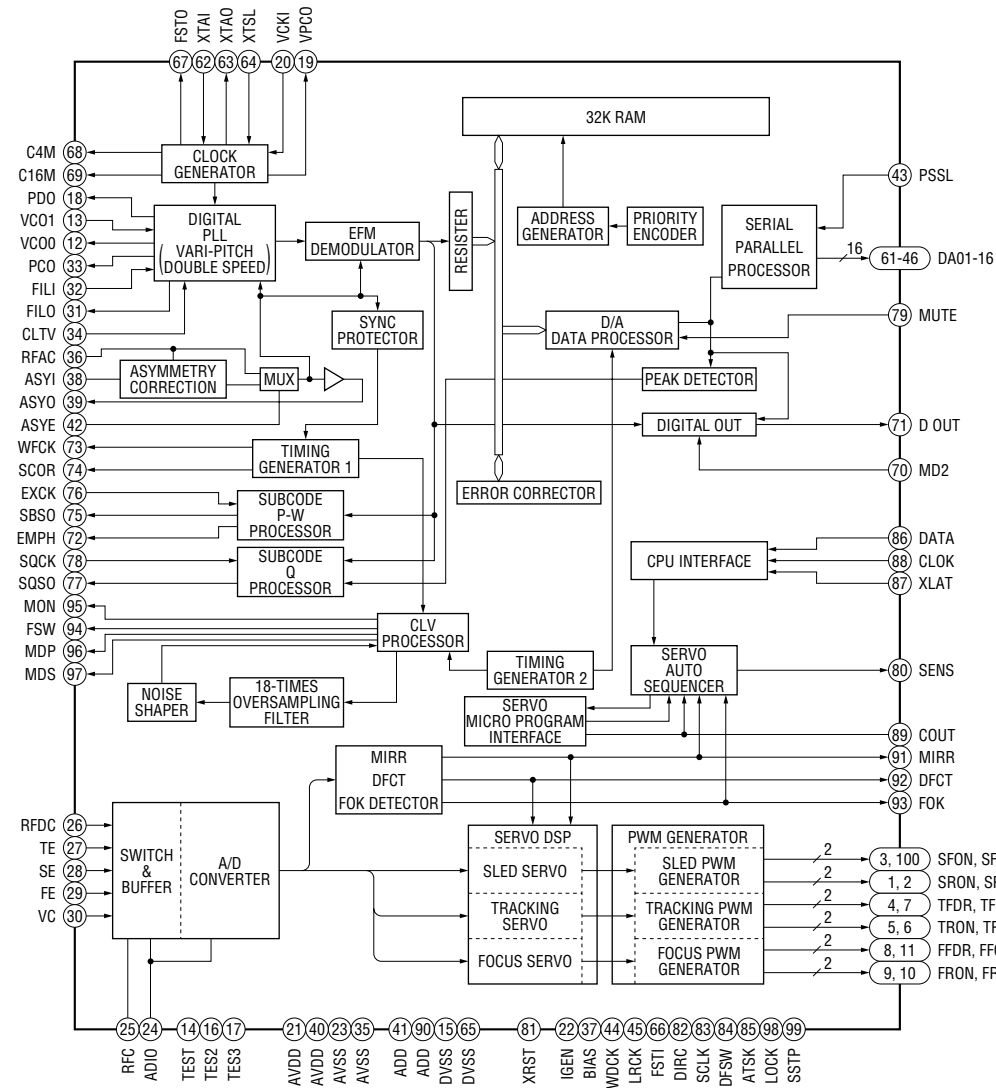

• VIDEO section

IC509 PCM1727E

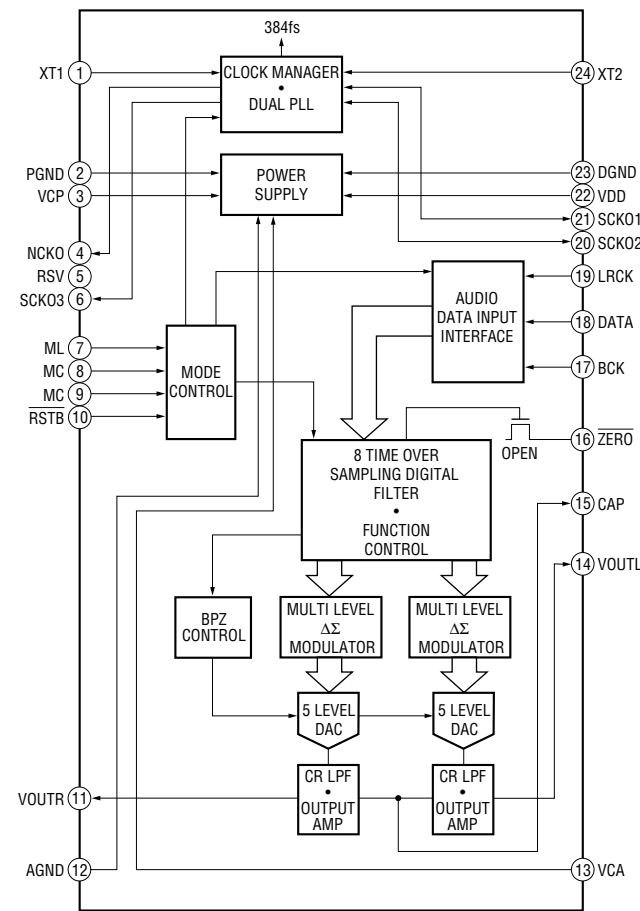

• DISPLAY section

IC603 BA3833F

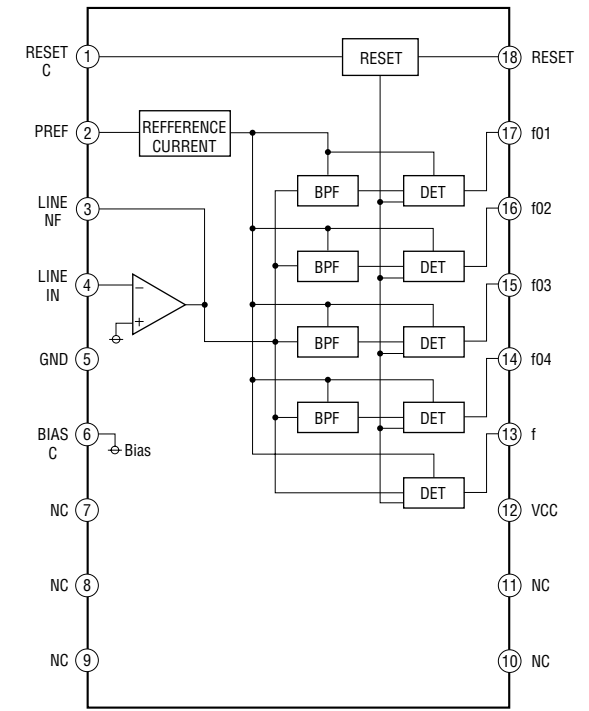

IC851 MSM6653A-517GS-K

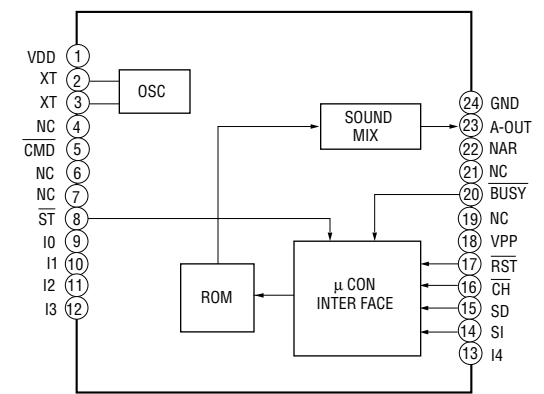

• Deck section

IC602 uPC1330HA

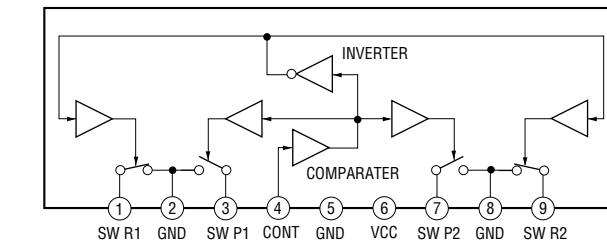

• MIC/HP section

IC751 M65850FP

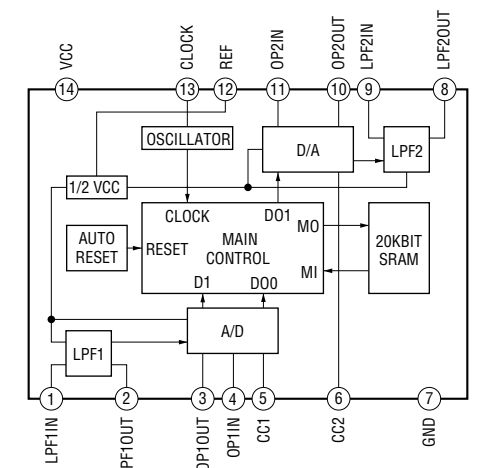

• CD motor section

IC701 M54641L

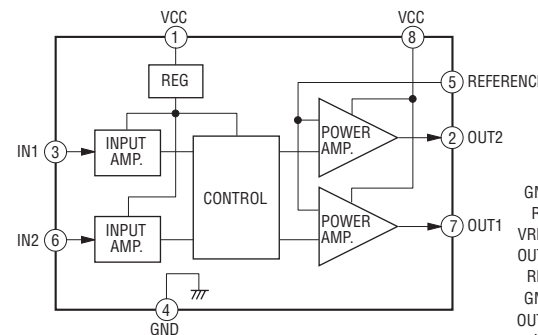

IC801 BA6286N

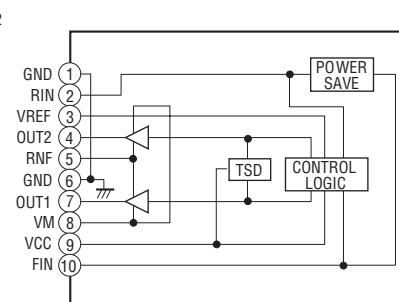

IC102 BA6392FP

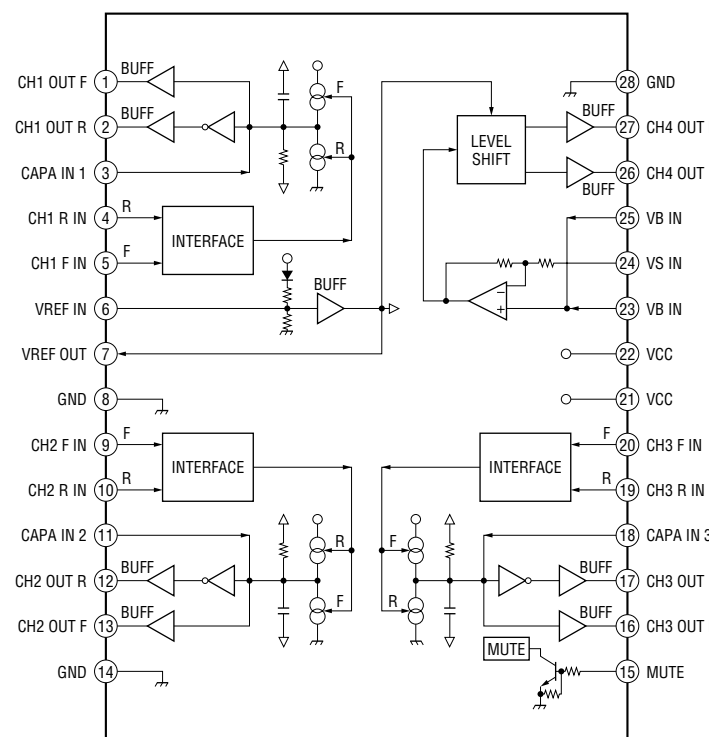

IC103 CXA1821M

