



PCA9633

4-bit Fm+ I²C-bus LED driver

Rev. 03 — 20 December 2006

Product data sheet

1. General description

The PCA9633 is an I²C-bus controlled 4-bit LED driver optimized for Red/Green/Blue/Amber (RGBA) color mixing applications. Each LED output has its own 8-bit resolution (256 steps) fixed frequency Individual PWM controller that operates at 97 kHz with a duty cycle that is adjustable from 0 % to 99.6 % to allow the LED to be set to a specific brightness value. A fifth 8-bit resolution (256 steps) Group PWM controller has both a fixed frequency of 190 Hz and an adjustable frequency between 24 Hz to once every 10.73 seconds with a duty cycle that is adjustable from 0 % to 99.6 % that is used to either dim or blink all LEDs with the same value.

Each LED output can be off, on (no PWM control), set at its Individual PWM controller value or at both Individual and Group PWM controller values. The LED output driver is programmed to be either open-drain with a 25 mA current sink capability at 5 V or totem-pole with a 25 mA sink, 10 mA source capability at 5 V. The PCA9633 operates with a supply voltage range of 2.3 V to 5.5 V and the outputs are 5.5 V tolerant. LEDs can be directly connected to the LED output (up to 25 mA, 5.5 V) or controlled with external drivers and a minimum amount of discrete components for larger current or higher voltage LEDs.

The PCA9633 is one of the first LED controller devices in a new Fast-mode Plus (Fm+) family. Fm+ devices offer higher frequency (up to 1 MHz) and more densely populated bus operation (up to 4000 pF).

The active LOW Output Enable input pin (\overline{OE}) allows asynchronous control of the LED outputs and can be used to set all the outputs to a defined I²C-bus programmable logic state. The \overline{OE} can also be used to externally PWM the outputs, which is useful when multiple devices need to be dimmed or blinked together using software control. This feature is available for the 16-pin version only.

Software programmable LED Group and three Sub Call I²C addresses allow all or defined groups of PCA9633 devices to respond to a common I²C address, allowing for example, all red LEDs to be turned on or off at the same time or marquee chasing effect, thus minimizing I²C-bus commands.

The PCA9633 is offered with 3 different I²C-bus address options: fixed I²C-bus address (8-pin version), 4 different I²C-bus addresses from 2 programmable address pins (10-pin version), and 126 different I²C-bus addresses from 7 programmable address pins (16-pin version). They are software identical except for the different number of address combinations.

The Software Reset (SWRST) Call allows the master to perform a reset of the PCA9633 through the I²C-bus, identical to the Power-On Reset (POR) that initializes the registers to their default state causing the outputs to be set HIGH (LED off). This allows an easy and quick way to reconfigure all device registers to the same condition.

2. Features

- 4 LED drivers. Each output programmable at:
 - ◆ Off
 - ◆ On
 - ◆ Programmable LED brightness
 - ◆ Programmable group dimming/blinking mixed with individual LED brightness
- 1 MHz Fast-mode Plus I²C-bus interface with 30 mA high drive capability on SDA output for driving high capacitive buses
- 256-step (8-bit) linear programmable brightness per LED output varying from fully off (default) to maximum brightness using a 97 kHz PWM signal
- 256-step group brightness control allows general dimming (using a 190 Hz PWM signal) from fully off to maximum brightness (default)
- 256-step group blinking with frequency programmable from 24 Hz to 10.73 s and duty cycle from 0 % to 99.6 %
- Four totem-pole outputs (sink 25 mA and source 10 mA at 5 V) with software programmable open-drain LED outputs selection (default at totem-pole). No input function.
- Output state change programmable on the Acknowledge or the STOP Command to update outputs byte-by-byte or all at the same time (default to 'Change on STOP').
- Active LOW Output Enable (\overline{OE}) input pin. LED outputs programmable to '1', '0' or 'high-impedance' (default at power-up) when \overline{OE} is HIGH, thus allowing hardware blinking and dimming of the LEDs (16-pin version only).
- 2 hardware address pins (10-pin version) and 7 hardware address pins (16-pin version) allow respectively up to 4 and 126 PCA9633 devices to be connected to the same I²C-bus. No hardware address pins in the 8-pin version.
- 4 software programmable I²C-bus addresses (one LED Group Call address and three LED Sub Call addresses) allow groups of devices to be addressed at the same time in any combination (for example, one register used for 'All Call' so that all the PCA9633s on the I²C-bus can be addressed at the same time and the second register used for three different addresses so that $\frac{1}{3}$ of all devices on the bus can be addressed at the same time in a group). Software enable and disable for I²C-bus address.
- Software Reset feature (SWRST Call) allows the device to be reset through the I²C-bus
- Up to 126 possible hardware adjustable individual I²C-bus addresses per device so that each device can be programmed individually.
- 25 MHz internal oscillator requires no external components
- Internal power-on reset
- Noise filter on SDA/SCL inputs
- Edge rate control on outputs
- No glitch on power-up
- Supports hot insertion
- Low standby current
- Operating power supply voltage range of 2.3 V to 5.5 V
- 5.5 V tolerant inputs
- -40 °C to +85 °C operation

- ESD protection exceeds 2000 V HBM per JESD22-A114, 200 V MM per JESD22-A115, and 1000 V CDM per JESD22-C101
- Latch-up testing is done to JEDEC Standard JESD78 which exceeds 100 mA
- Packages offered: SO, TSSOP (MSOP), HVQFN, HVSON

3. Applications

- RGB or RGBA LED drivers
- LED status information
- LED displays
- LCD backlights
- Keypad backlights for cellular phones or handheld devices

4. Ordering information

Table 1. Ordering information

| Type number | Topside mark | Package | | |
|-------------|--------------|---------|---|----------|
| | | Name | Description | Version |
| PCA9633D16 | PCA9633 | SO16 | plastic small outline package; 16 leads; body width 3.9 mm | SOT109-1 |
| PCA9633DP1 | 9633 | TSSOP8 | plastic thin shrink small outline package; 8 leads; body width 3 mm | SOT505-1 |
| PCA9633DP2 | 9633 | TSSOP10 | plastic thin shrink small outline package; 10 leads; body width 3 mm | SOT552-1 |
| PCA9633PW | PCA9633 | TSSOP16 | plastic thin shrink small outline package; 16 leads; body width 4.4 mm | SOT403-1 |
| PCA9633BS | 9633 | HVQFN16 | plastic thermal enhanced very thin quad flat package; no leads; 16 terminals; body 4 × 4 × 0.85 mm | SOT629-1 |
| PCA9633TK | 9633 | HVSON8 | plastic thermal enhanced very thin small outline package; no leads; 8 terminals; body 3 × 3 × 0.85 mm | SOT908-1 |

5. Block diagram

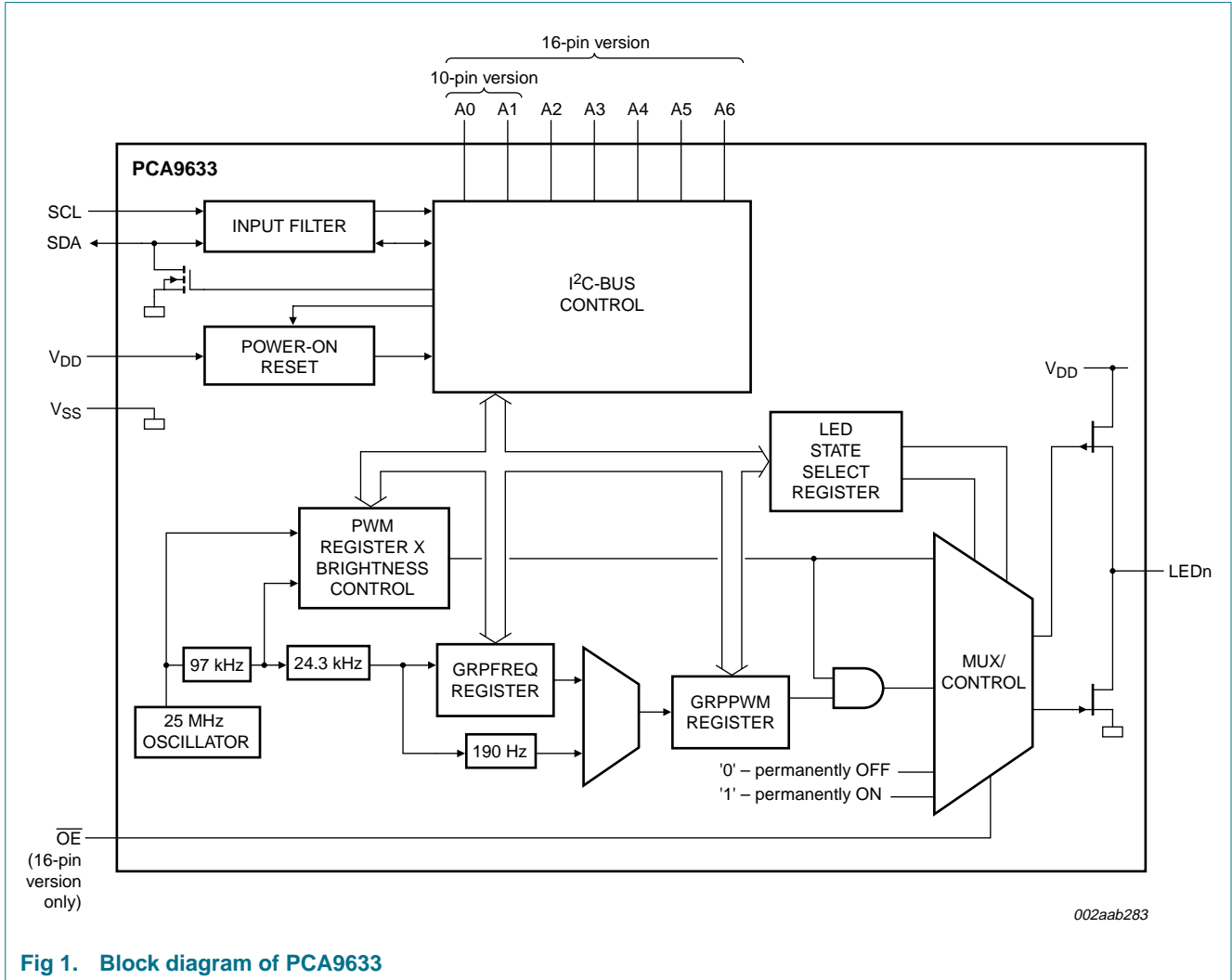

Fig 1. Block diagram of PCA9633

6. Pinning information

6.1 Pinning

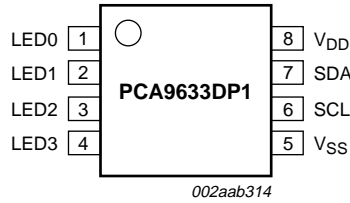

Fig 2. Pin configuration for TSSOP8

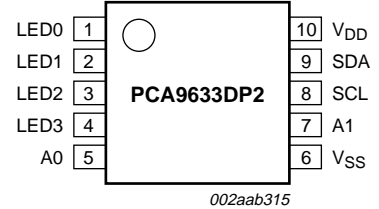

Fig 3. Pin configuration for TSSOP10

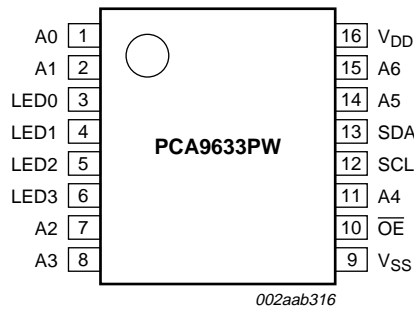

Fig 4. Pin configuration for TSSOP16

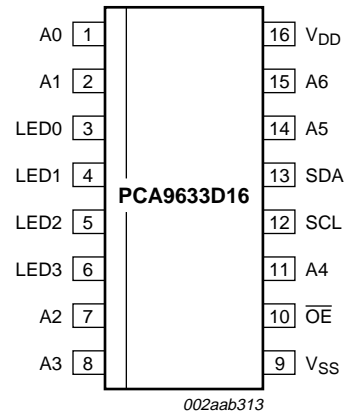

Fig 5. Pin configuration for SO16

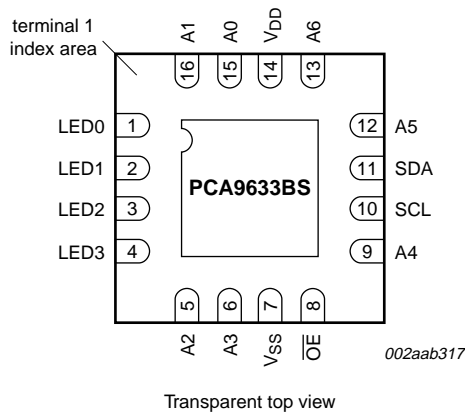

Fig 6. Pin configuration for HVQFN16

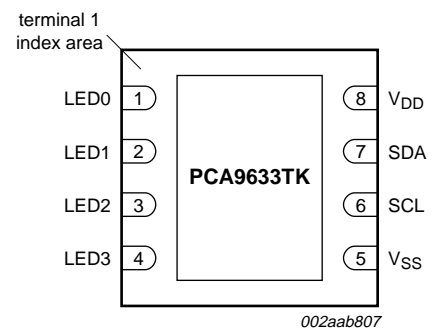

Fig 7. Pin configuration for HVSON8

6.2 Pin description

Table 2. Pin description for TSSOP8 and HVSON8

| Symbol | Pin | Type | Description |
|-----------------|-----|--------------|-------------------|
| LED0 | 1 | O | LED driver 0 |
| LED1 | 2 | O | LED driver 1 |
| LED2 | 3 | O | LED driver 2 |
| LED3 | 4 | O | LED driver 3 |
| V _{SS} | 5 | power supply | supply ground |
| SCL | 6 | I | serial clock line |
| SDA | 7 | I/O | serial data line |
| V _{DD} | 8 | power supply | supply voltage |

Table 3. Pin description for TSSOP10

| Symbol | Pin | Type | Description |
|-----------------|-----|--------------|-------------------|
| LED0 | 1 | O | LED driver 0 |
| LED1 | 2 | O | LED driver 1 |
| LED2 | 3 | O | LED driver 2 |
| LED3 | 4 | O | LED driver 3 |
| A0 | 5 | I | address input 0 |
| V _{SS} | 6 | power supply | supply ground |
| A1 | 7 | I | address input 1 |
| SCL | 8 | I | serial clock line |
| SDA | 9 | I/O | serial data line |
| V _{DD} | 10 | power supply | supply voltage |

Table 4. Pin description for SO16 and TSSOP16

| Symbol | Pin | Type | Description |
|------------------------|-----|--------------|--------------------------|
| A0 | 1 | I | address input 0 |
| A1 | 2 | I | address input 1 |
| LED0 | 3 | O | LED driver 0 |
| LED1 | 4 | O | LED driver 1 |
| LED2 | 5 | O | LED driver 2 |
| LED3 | 6 | O | LED driver 3 |
| A2 | 7 | I | address input 2 |
| A3 | 8 | I | address input 3 |
| V _{SS} | 9 | power supply | supply ground |
| $\overline{\text{OE}}$ | 10 | I | active LOW Output Enable |
| A4 | 11 | I | address input 4 |
| SCL | 12 | I | serial clock line |
| SDA | 13 | I/O | serial data line |
| A5 | 14 | I | address input 5 |
| A6 | 15 | I | address input 6 |
| V _{DD} | 16 | power supply | supply voltage |

Table 5. Pin description for HVQFN16

| Symbol | Pin | Type | Description |
|--------------------------------|-----|--------------|--------------------------|
| LED0 | 1 | O | LED driver 0 |
| LED1 | 2 | O | LED driver 1 |
| LED2 | 3 | O | LED driver 2 |
| LED3 | 4 | O | LED driver 3 |
| A2 | 5 | I | address input 2 |
| A3 | 6 | I | address input 3 |
| V _{SS} ^[1] | 7 | power supply | supply ground |
| $\overline{\text{OE}}$ | 8 | I | active LOW Output Enable |
| A4 | 9 | I | address input 4 |
| SCL | 10 | I | serial clock line |
| SDA | 11 | I/O | serial data line |
| A5 | 12 | I | address input 5 |
| A6 | 13 | I | address input 6 |
| V _{DD} | 14 | power supply | supply voltage |
| A0 | 15 | I | address input 0 |
| A1 | 16 | I | address input 1 |

- [1] HVQFN package die supply ground is connected to both the V_{SS} pin and the exposed center pad. The V_{SS} pin must be connected to supply ground for proper device operation. For enhanced thermal, electrical, and board-level performance, the exposed pad needs to be soldered to the board using a corresponding thermal pad on the board, and for proper heat conduction through the board thermal vias need to be incorporated in the PCB in the thermal pad region.

7. Functional description

Refer to [Figure 1 “Block diagram of PCA9633”](#).

7.1 Device addresses

Following a START condition, the bus master must output the address of the slave it is accessing.

There are a maximum of 128 possible programmable addresses using the 7 hardware address pins. Two of these addresses, Software Reset and LED All Call, cannot be used because their default power-up state is ON, leaving a maximum of 126 addresses. Using other reserved addresses, as well as any other subcall address, will reduce the total number of possible addresses even further.

7.1.1 Regular I²C-bus slave address

The I²C-bus slave address of the PCA9633 is shown in [Figure 8](#). To conserve power, no internal pull-up resistors are incorporated on the hardware selectable address pins and they must be pulled HIGH or LOW (10-pin and 16-pin versions).

Remark: For the 16-pin version, reserved I²C-bus addresses must be used with caution since they can interfere with:

- ‘reserved for future use’ I²C-bus addresses (0000 011, 1111 1XX)
- slave devices that use the 10-bit addressing scheme (1111 0XX)
- slave devices that are designed to respond to the General Call address (0000 000)
- High-speed mode (Hs-mode) master code (0000 1XX).

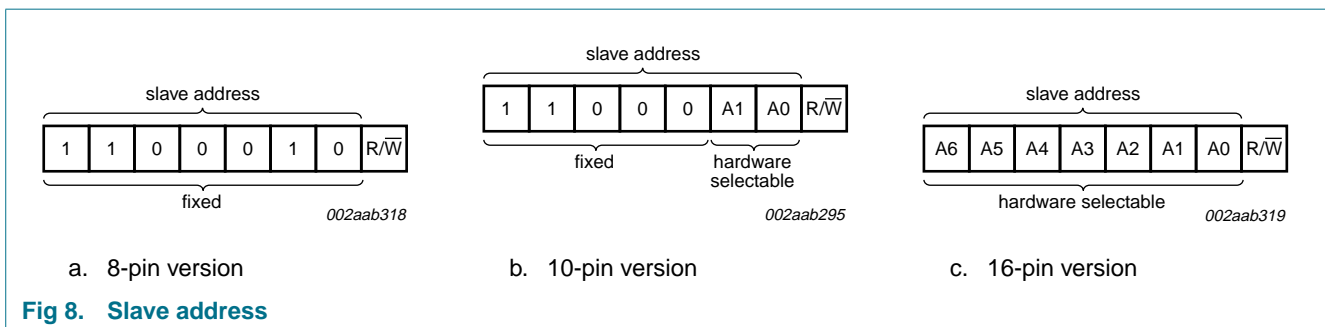

The last bit of the address byte defines the operation to be performed. When set to logic 1 a read is selected, while a logic 0 selects a write operation.

7.1.2 LED All Call I²C-bus address

- Default power-up value (ALLCALLADR register): E0h or 1110 000
- Programmable through I²C-bus (volatile programming)
- At power-up, LED All Call I²C-bus address is enabled. PCA9633 sends an ACK when E0h (R/W = 0) or E1h (R/W = 1) is sent by the master.

See [Section 7.3.8 “LED All Call I²C-bus address, ALLCALLADR”](#) for more detail.

Remark: The default LED All Call I²C-bus address (E0h or 1110 000) must not be used as a regular I²C-bus slave address since this address is enabled at power-up. All the PCA9633s on the I²C-bus will acknowledge the address if sent by the I²C-bus master.

7.1.3 LED Sub Call I²C-bus addresses

- 3 different I²C-bus addresses can be used
- Default power-up values:
 - SUBADR1 register: E2h or 1110 001
 - SUBADR2 register: E4h or 1110 010
 - SUBADR3 register: E8h or 1110 100
- Programmable through I²C-bus (volatile programming)
- At power-up, Sub Call I²C-bus addresses are disabled. PCA9633 does not send an ACK when E2h ($R/\overline{W} = 0$) or E3h ($R/\overline{W} = 1$), E4h ($R/\overline{W} = 0$) or E5h ($R/\overline{W} = 1$), or E8h ($R/\overline{W} = 0$) or E9h ($R/\overline{W} = 1$) is sent by the master.

See [Section 7.3.7 “I²C-bus subaddress 1 to 3, SUBADR_x”](#) for more detail.

Remark: The default LED Sub Call I²C-bus addresses may be used as regular I²C-bus slave addresses as long as they are disabled.

7.1.4 Software Reset I²C-bus address

The address shown in [Figure 9](#) is used when a reset of the PCA9633 needs to be performed by the master. The Software Reset address (SWRST Call) must be used with $R/\overline{W} = 0$. If $R/\overline{W} = 1$, the PCA9633 does not acknowledge the SWRST. See [Section 7.6 “Software Reset”](#) for more detail.

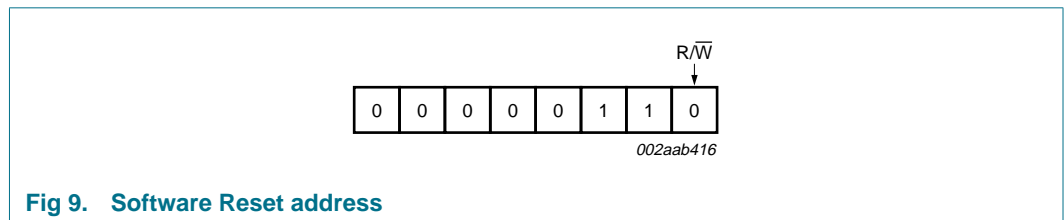

Fig 9. Software Reset address

Remark: The Software Reset I²C-bus address is a reserved address and cannot be used as a regular I²C-bus slave address (16-pin version) or as an LED All Call or LED Sub Call address.

7.2 Control register

Following the successful acknowledgement of the slave address, LED All Call address or LED Sub Call address, the bus master will send a byte to the PCA9633, which will be stored in the Control register.

The lowest 4 bits are used as a pointer to determine which register will be accessed (D[3:0]). The highest 3 bits are used as Auto-Increment flag and Auto-Increment options (AI[2:0]). Bit 4 is unused and must be programmed with zero (0) for proper device operation.

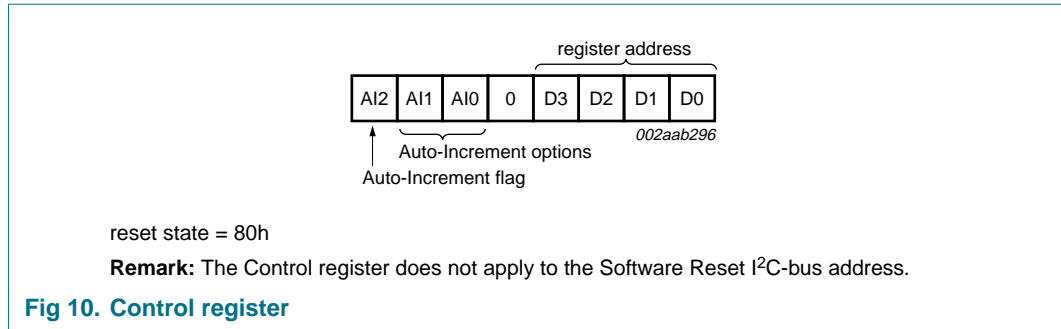

When the Auto-Increment flag is set (AI2 = 1), the four low order bits of the Control register are automatically incremented after a read or write. This allows the user to program the registers sequentially. Four different types of Auto-Increment are possible, depending on AI1 and AI0 values.

Table 6. Auto-Increment options

| AI2 | AI1 | AI0 | Function |
|-----|-----|-----|---|
| 0 | 0 | 0 | no Auto-Increment |
| 1 | 0 | 0 | Auto-Increment for all registers. D3, D2, D1, D0 roll over to '0000' after the last register (1100) is accessed. |
| 1 | 0 | 1 | Auto-Increment for individual brightness registers only. D3, D2, D1, D0 roll over to '0010' after the last register (0101) is accessed. |
| 1 | 1 | 0 | Auto-Increment for global control registers only. D3, D2, D1, D0 roll over to '0110' after the last register (0111) is accessed. |
| 1 | 1 | 1 | Auto-Increment for individual and global control registers only. D3, D2, D1, D0 roll over to '0010' after the last register (0111) is accessed. |

Remark: Other combinations not shown in [Table 6](#) (AI[2:0] = 001, 010, and 011) are reserved and must not be used for proper device operation.

AI[2:0] = 000 is used when the same register must be accessed several times during a single I²C-bus communication, for example, changes the brightness of a single LED. Data is overwritten each time the register is accessed during a write operation.

AI[2:0] = 100 is used when all the registers must be sequentially accessed, for example, power-up programming.

AI[2:0] = 101 is used when the four LED drivers must be individually programmed with different values during the same I²C-bus communication, for example, changing color setting to another color setting.

AI[2:0] = 110 is used when the LED drivers must be globally programmed with different settings during the same I²C-bus communication, for example, global brightness or blinking change.

AI[2:0] = 111 is used when individual and global changes must be performed during the same I²C-bus communication, for example, changing a color and global brightness at the same time.

Only the 4 least significant bits D[3:0] are affected by the AI[2:0] bits.

When the Control register is written, the register entry point determined by D[3:0] is the first register that will be addressed (read or write operation), and can be anywhere between 0000 and 1100 (as defined in [Table 7](#)). When AI[2] = 1, the Auto-Increment flag is set and the rollover value at which the point where the register increment stops and goes to the next one is determined by AI[2:0]. See [Table 6](#) for rollover values. For example, if the Control register = 1110 1000 (E8h), then the register addressing sequence will be (in hex):
 08 → ... → 0C → 00 → ... → 07 → 02 → ... → 07 → 02 → ... → 07 → 02 → ... as long as the master keeps sending or reading data.

7.3 Register definitions

Table 7. Register summary^{[1][2]}

| Register number (hex) | D3 | D2 | D1 | D0 | Name | Type | Function |
|-----------------------|----|----|----|----|------------|------------|---|
| 00h | 0 | 0 | 0 | 0 | MODE1 | read/write | Mode register 1 |
| 01h | 0 | 0 | 0 | 1 | MODE2 | read/write | Mode register 2 |
| 02h | 0 | 0 | 1 | 0 | PWM0 | read/write | brightness control LED0 |
| 03h | 0 | 0 | 1 | 1 | PWM1 | read/write | brightness control LED1 |
| 04h | 0 | 1 | 0 | 0 | PWM2 | read/write | brightness control LED2 |
| 05h | 0 | 1 | 0 | 1 | PWM3 | read/write | brightness control LED3 |
| 06h | 0 | 1 | 1 | 0 | GRPPWM | read/write | group duty cycle control |
| 07h | 0 | 1 | 1 | 1 | GRPFREQ | read/write | group frequency |
| 08h | 1 | 0 | 0 | 0 | LEDOUT | read/write | LED output state |
| 09h | 1 | 0 | 0 | 1 | SUBADR1 | read/write | I ² C-bus subaddress 1 |
| 0Ah | 1 | 0 | 1 | 0 | SUBADR2 | read/write | I ² C-bus subaddress 2 |
| 0Bh | 1 | 0 | 1 | 1 | SUBADR3 | read/write | I ² C-bus subaddress 3 |
| 0Ch | 1 | 1 | 0 | 0 | ALLCALLADR | read/write | LED All Call I ² C-bus address |

[1] Only D[3:0] = 0000 to 1100 are allowed and will be acknowledged. D[3:0] = 1101, 1110, or 1111 are reserved and will not be acknowledged.

[2] When writing to the Control register, bit 4 must be programmed with logic 0 for proper device operation.

7.3.1 Mode register 1, MODE1

Table 8. MODE1 - Mode register 1 (address 00h) bit description

Legend: * default value.

| Bit | Symbol | Access | Value | Description |
|-----|---------|-----------|-------|--|
| 7 | AI2 | read only | 0 | Register Auto-Increment disabled |
| | | | 1* | Register Auto-Increment enabled |
| 6 | AI1 | read only | 0* | Auto-Increment bit 1 = 0 |
| | | | 1 | Auto-Increment bit 1 = 1 |
| 5 | AI0 | read only | 0* | Auto-Increment bit 0 = 0 |
| | | | 1 | Auto-Increment bit 0 = 1 |
| 4 | SLEEP | R/W | 0 | Normal mode ^[1] . |
| | | | 1* | Low power mode. Oscillator off ^[2] . |
| 3 | SUB1 | R/W | 0* | PCA9633 does not respond to I ² C-bus subaddress 1. |
| | | | 1 | PCA9633 responds to I ² C-bus subaddress 1. |
| 2 | SUB2 | R/W | 0* | PCA9633 does not respond to I ² C-bus subaddress 2. |
| | | | 1 | PCA9633 responds to I ² C-bus subaddress 2. |
| 1 | SUB3 | R/W | 0* | PCA9633 does not respond to I ² C-bus subaddress 3. |
| | | | 1 | PCA9633 responds to I ² C-bus subaddress 3. |
| 0 | ALLCALL | R/W | 0 | PCA9633 does not respond to LED All Call I ² C-bus address. |
| | | | 1* | PCA9633 responds to LED All Call I ² C-bus address. |

[1] It takes 500 μ s max. for the oscillator to be up and running once SLEEP bit has been set to logic 1. Timings on LEDn outputs are not guaranteed if PWMx, GRPPWM or GRPFREQ registers are accessed within the 500 μ s window.

[2] No blinking or dimming is possible when the oscillator is off.

7.3.2 Mode register 2, MODE2

Table 9. MODE2 - Mode register 2 (address 01h) bit description

Legend: * default value.

| Bit | Symbol | Access | Value | Description |
|-----|-----------------------|-----------|-------|---|
| 7 | - | read only | 0* | reserved |
| 6 | - | read only | 0* | reserved |
| 5 | DMBLNK | R/W | 0* | Group control = dimming |
| | | | 1 | Group control = blinking |
| 4 | INVRT ^[1] | R/W | 0* | Output logic state not inverted. Value to use when no external driver used. Applicable when $\overline{OE} = 0$ for PCA9633 16-pin version. |
| | | | 1 | Output logic state inverted. Value to use when external driver used. Applicable when $\overline{OE} = 0$ for PCA9633 16-pin version. |
| 3 | OCH | R/W | 0* | Outputs change on STOP command ^[2] |
| | | | 1 | Outputs change on ACK. |
| 2 | OUTDRV ^[1] | R/W | 0 | The 4 LED outputs are configured with an open-drain structure. |
| | | | 1* | The 4 LED outputs are configured with a totem-pole structure. |

Table 9. MODE2 - Mode register 2 (address 01h) bit description ...continued

Legend: * default value.

| Bit | Symbol | Access | Value | Description |
|--------|--------------------------------------|--------|-------|---|
| 1 to 0 | OUTNE[1:0] [3][4] | R/W | 00 | When $\overline{OE} = 1$ (output drivers not enabled), LEDn = 0. |
| | | | 01* | When $\overline{OE} = 1$ (output drivers not enabled): LEDn = 1 when OUTDRV = 1 LEDn = high-impedance when OUTDRV = 0 (same as OUTNE[1:0] = 10) |
| | | | 10 | When $\overline{OE} = 1$ (output drivers not enabled), LEDn = high-impedance. |
| | | | 11 | reserved |

- [1] See [Section 7.7 “Using the PCA9633 with and without external drivers”](#) for more details.
- [2] Change of the outputs at the STOP command allows synchronizing outputs of more than one PCA9633. Applicable to registers from 02h (PWM0) to 08h (LEDOUT) only.
- [3] See [Section 7.4 “Active LOW output enable input”](#) for more details.
- [4] OUTNE[1:0] is only for PCA9633 16-pin version.

7.3.3 PWM registers 0 to 3, PWMx—Individual brightness control registers

Table 10. PWM0 to PWM3 - PWM registers 0 to 3 (address 02h to 05h) bit description

Legend: * default value.

| Address | Register | Bit | Symbol | Access | Value | Description |
|---------|----------|-----|-----------|--------|------------|----------------------------|
| 02h | PWM0 | 7:0 | IDC0[7:0] | R/W | 0000 0000* | PWM0 Individual Duty Cycle |
| 03h | PWM1 | 7:0 | IDC1[7:0] | R/W | 0000 0000* | PWM1 Individual Duty Cycle |
| 04h | PWM2 | 7:0 | IDC2[7:0] | R/W | 0000 0000* | PWM2 Individual Duty Cycle |
| 05h | PWM3 | 7:0 | IDC3[7:0] | R/W | 0000 0000* | PWM3 Individual Duty Cycle |

A 97 kHz fixed frequency signal is used for each output. Duty cycle is controlled through 256 linear steps from 00h (0 % duty cycle = LED output off) to FFh (99.6 % duty cycle = LED output at maximum brightness). Applicable to LED outputs programmed with LDRx = 10 or 11 (LEDOUT register).

$$duty\ cycle = \frac{IDC[7:0]}{256}$$

7.3.4 Group duty cycle control, GRPPWM

Table 11. GRPPWM - Group duty cycle control register (address 06h) bit description

Legend: * default value.

| Address | Register | Bit | Symbol | Access | Value | Description |
|---------|----------|-----|----------|--------|-----------|-----------------|
| 06h | GRPPWM | 7:0 | GDC[7:0] | R/W | 1111 1111 | GRPPWM register |

When DMBLNK bit (MODE2 register) is programmed with 0, a 190 Hz fixed frequency signal is superimposed with the 97 kHz individual brightness control signal. GRPPWM is then used as a global brightness control allowing the LED outputs to be dimmed with the same value. The value in GRPFREQ is then a ‘Don’t care’.

General brightness for the 4 outputs is controlled through 256 linear steps from 00h (0 % duty cycle = LED output off) to FFh (99.6 % duty cycle = maximum brightness). Applicable to LED outputs programmed with LDRx = 11 (LEDOUT register).

When DMBLNK bit is programmed with 1, GRPPWM and GRPFREQ registers define a global blinking pattern, where GRPFREQ contains the blinking period (from 24 Hz to 10.73 s) and GRPPWM the duty cycle (ON/OFF ratio in %).

$$duty\ cycle = \frac{GDC[7:0]}{256}$$

7.3.5 Group frequency, GRPFREQ

Table 12. GRPFREQ - Group Frequency register (address 07h) bit description

Legend: * default value.

| Address | Register | Bit | Symbol | Access | Value | Description |
|---------|----------|-----|-----------|--------|------------|------------------|
| 07h | GRPFREQ | 7:0 | GFRQ[7:0] | R/W | 0000 0000* | GRPFREQ register |

GRPFREQ is used to program the global blinking period when DMBLNK bit (MODE2 register) is equal to 1. Value in this register is a 'Don't care' when DMBLNK = 0. Applicable to LED outputs programmed with LDRx = 11 (LEDOUT register).

Blinking period is controlled through 256 linear steps from 00h (41 ms, frequency 24 Hz) to FFh (10.73 s).

$$global\ blinking\ period = \frac{GFRQ[7:0] + 1}{24} \text{ (in seconds)}$$

7.3.6 LED driver output state, LEDOUT

Table 13. LEDOUT - LED driver output state register (address 08h) bit description

Legend: * default value.

| Address | Register | Bit | Symbol | Access | Value | Description |
|---------|----------|-----|--------|--------|-------|---------------------------|
| 08h | LEDOUT | 7:6 | LDR3 | R/W | 00* | LED3 output state control |
| | | 5:4 | LDR2 | R/W | 00* | LED2 output state control |
| | | 3:2 | LDR1 | R/W | 00* | LED1 output state control |
| | | 1:0 | LDR0 | R/W | 00* | LED0 output state control |

LDRx = 00 — LED driver x is off (default power-up state).

LDRx = 01 — LED driver x is fully on (individual brightness and group dimming/blinking not controlled).

LDRx = 10 — LED driver x individual brightness can be controlled through its PWMx register.

LDRx = 11 — LED driver x individual brightness and group dimming/blinking can be controlled through its PWMx register and the GRPPWM registers.

7.3.7 I²C-bus subaddress 1 to 3, SUBADR_x

Table 14. SUBADR1 to SUBADR3 - I²C-bus subaddress registers 0 to 3 (address 09h to 0Bh) bit description

Legend: * default value.

| Address | Register | Bit | Symbol | Access | Value | Description |
|---------|----------|-----|---------|--------|-----------|-----------------------------------|
| 09h | SUBADR1 | 7:1 | A1[7:1] | R/W | 1110 001* | I ² C-bus subaddress 1 |
| | | 0 | A1[0] | R only | 0* | reserved |
| 0Ah | SUBADR2 | 7:1 | A2[7:1] | R/W | 1110 010* | I ² C-bus subaddress 2 |
| | | 0 | A2[0] | R only | 0* | reserved |
| 0Bh | SUBADR3 | 7:1 | A3[7:1] | R/W | 1110 100* | I ² C-bus subaddress 3 |
| | | 0 | A3[0] | R only | 0* | reserved |

Subaddresses are programmable through the I²C-bus. Default power-up values are E2h, E4h, E8h, and the device(s) will not acknowledge these addresses right after power-up (the corresponding SUB_x bit in MODE1 register is equal to 0).

Once subaddresses have been programmed to their right values, SUB_x bits need to be set to 1 in order to have the device acknowledging these addresses (MODE1 register).

Only the 7 MSBs representing the I²C-bus subaddress are valid. The LSB in SUBADR_x register is a read-only bit (0).

When SUB_x is set to 1, the corresponding I²C-bus subaddress can be used during either an I²C-bus read or write sequence.

7.3.8 LED All Call I²C-bus address, ALLCALLADR

Table 15. ALLCALLADR - LED All Call I²C-bus address register (address 0Ch) bit description

Legend: * default value.

| Address | Register | Bit | Symbol | Access | Value | Description |
|---------|------------|-----|---------|--------|-----------|---|
| 0Ch | ALLCALLADR | 7:1 | AC[7:1] | R/W | 1110 000* | ALLCALL I ² C-bus address register |
| | | 0 | AC[0] | R only | 0* | reserved |

The LED All Call I²C-bus address allows all the PCA9633s in the bus to be programmed at the same time (ALLCALL bit in register MODE1 must be equal to 1, power-up default state). This address is programmable through the I²C-bus and can be used during either an I²C-bus read or write sequence. The register address can be programmed as a sub call.

Only the 7 MSBs representing the All Call I²C-bus address are valid. The LSB in ALLCALLADR register is a Read-only bit (0).

If ALLCALL bit = 0, the device does not acknowledge the address programmed in register ALLCALLADR.

7.4 Active LOW output enable input

The active LOW output enable (\overline{OE}) pin, allows to enable or disable all the LED outputs at the same time.

This control signal is only available for the 16-pin version and does not apply to the 8-pin or 10-pin versions.

- When a LOW level is applied to \overline{OE} pin, all the LED outputs are enabled and follow the output state defined in the LEDOUT register with the polarity defined by INVRT bit (MODE2 register).
- When a HIGH level is applied to \overline{OE} pin, all the LED outputs are programmed to the value that is defined by OUTNE[1:0] in the MODE2 register.

Table 16. LED outputs when $\overline{OE} = 1$

| OUTNE1 | OUTNE0 | LED outputs |
|--------|--------|---|
| 0 | 0 | 0 |
| 0 | 1 | 1 if OUTDRV = 1, high-impedance if OUTDRV = 0 |
| 1 | 0 | high-impedance |
| 1 | 1 | reserved |

The \overline{OE} pin can be used as a synchronization signal to switch on/off several PCA9633 devices at the same time. This requires an external clock reference that provides blinking period and the duty cycle.

The \overline{OE} pin can also be used as an external dimming control signal. The frequency of the external clock must be high enough not to be seen by the human eye, and the duty cycle value determines the brightness of the LEDs.

Remark: Do not use \overline{OE} as an external blinking control signal when internal global blinking is selected (DMBLNK = 1, MODE2 register) since it will result in an undefined blinking pattern. Do not use \overline{OE} as an external dimming control signal when internal global dimming is selected (DMBLNK = 0, MODE2 register) since it will result in an undefined dimming pattern.

7.5 Power-on reset

When power is applied to V_{DD} , an internal Power-on reset holds the PCA9633 in a reset condition until V_{DD} has reached V_{POR} . At this point, the reset condition is released and the PCA9633 registers and I²C-bus state machine are initialized to their default states (all zeroes) causing all the channels to be deselected. Thereafter, V_{DD} must be lowered below 0.2 V to reset the device.

7.6 Software Reset

The Software Reset Call (SWRST Call) allows all the devices in the I²C-bus to be reset to the power-up state value through a specific formatted I²C-bus command. To be performed correctly, it implies that the I²C-bus is functional and that there is no device hanging the bus.

The SWRST Call function is defined as the following:

1. A START command is sent by the I²C-bus master.
2. The reserved SWRST I²C-bus address '0000 011' with the R/\overline{W} bit set to 0 (write) is sent by the I²C-bus master.
3. The PCA9633 device(s) acknowledge(s) after seeing the SWRST Call address '0000 0110' (06h) only. If the R/\overline{W} bit is set to 1 (read), no acknowledge is returned to the I²C-bus master.
4. Once the SWRST Call address has been sent and acknowledged, the master sends 2 bytes with 2 specific values (SWRST data byte 1 and byte 2):
 - a. Byte 1 = A5h: the PCA9633 acknowledges this value only. If byte 1 is not equal to A5h, the PCA9633 does not acknowledge it.
 - b. Byte 2 = 5Ah: the PCA9633 acknowledges this value only. If byte 2 is not equal to 5Ah, then the PCA9633 does not acknowledge it.

If more than 2 bytes of data are sent, the PCA9633 does not acknowledge any more.

5. Once the right 2 bytes (SWRST data byte 1 and byte 2 only) have been sent and correctly acknowledged, the master sends a STOP command to end the SWRST Call: the PCA9633 then resets to the default value (power-up value) and is ready to be addressed again within the specified bus free time (t_{BUF}).

The I²C-bus master must interpret a non-acknowledge from the PCA9633 (at any time) as a 'SWRST Call Abort'. The PCA9633 does not initiate a reset of its registers. This happens only when the format of the SWRST Call sequence is not correct.

7.7 Using the PCA9633 with and without external drivers

The PCA9633 LED output drivers are 5.5 V only tolerant and can sink up to 25 mA at 5 V.

If the device needs to drive LEDs to a higher voltage and/or higher current, use of an external driver is required.

- INVRT bit (MODE2 register) can be used to keep the LED PWM control firmware the same (PWMx and GRPPWM values directly calculated from their respective formulas and the LED output state determined by LEDOUT register value) independently of the type of external driver. This bit allows LED output polarity inversion/non-inversion only when $\overline{OE} = 0$.
- OUTDRV bit (MODE2 register) allows minimizing the amount of external components required to control the external driver (N-type or P-type device).

Table 17. Use of INVRT and OUTDRV based on connection to the LEDn outputs when $\overline{OE} = 0$

| INVRT | OUTDRV | Direct connection to LEDn | | External N-type driver | | External P-type driver | |
|-------|--------|---|---------------------------------------|---|-----------------------------|---|-----------------------------|
| | | Firmware | External pull-up resistor | Firmware | External pull-up resistor | Firmware | External pull-up resistor |
| 0 | 0 | formulas and LED output state values apply ^[2] | LED current limiting R ^[2] | formulas and LED output state values inverted | required | formulas and LED output state values apply | required |
| 0 | 1 | formulas and LED output state values apply ^[2] | LED current limiting R ^[2] | formulas and LED output state values inverted | not required | formulas and LED output state values apply ^[4] | not required ^[4] |
| 1 | 0 | formulas and LED output state values inverted | LED current limiting R | formulas and LED output state values apply | required | formulas and LED output state values inverted | required |
| 1 | 1 | formulas and LED output state values inverted | LED current limiting R | formulas and LED output state values apply ^[3] | not required ^[3] | formulas and LED output state values inverted | not required |

[1] \overline{OE} applies to 16-pin version only. When $\overline{OE} = 1$, LED output state is controlled only by OUTNE[1:0] bits (MODE2 register).

[2] Correct configuration when LEDs directly connected to the LEDn outputs (connection to V_{DD} through current limiting resistor).

[3] Optimum configuration when external N-type (NPN, NMOS) driver used.

[4] Optimum configuration when external P-type (PNP, PMOS) driver used.

Table 18. Output transistors based on LEDOUT registers, INVRT and OUTDRV bits when $\overline{OE} = 0$ ^[1]

| LEDOUT | INVRT | OUTDRV | Upper transistor (V _{DD} to LEDn) | Lower transistor (LEDn to V _{SS}) | LEDn state |
|---|-------|--------|--|---|--|
| 00 | 0 | 0 | off | off | high-Z ^[2] |
| LED driver off | 0 | 1 | on | off | V _{DD} |
| | 1 | 0 | off | on | V _{SS} |
| | 1 | 1 | off | on | V _{SS} |
| 01 | 0 | 0 | off | on | V _{SS} |
| LED driver on | 0 | 1 | off | on | V _{SS} |
| | 1 | 0 | off | off | high-Z ^[2] |
| | 1 | 1 | on | off | V _{DD} |
| 10 Individual brightness control | 0 | 0 | off | Individual PWM (non-inverted) | V _{SS} or high-Z ^[2] = PWMx value |
| | 0 | 1 | Individual PWM (non-inverted) | Individual PWM (non-inverted) | V _{SS} or V _{DD} = PWMx value |
| | 1 | 0 | off | Individual PWM (inverted) | high-Z ^[2] or V _{SS} = 1 – PWMx value |
| | 1 | 1 | Individual PWM (inverted) | Individual PWM (inverted) | V _{DD} or V _{SS} = 1 – PWMx value |
| 11 Individual + Group dimming/blinking | 0 | 0 | off | Individual + Group PWM (non-inverted) | V _{SS} or high-Z ^[2] = PWMx/GRPPWM values |
| | 0 | 1 | Individual PWM (non-inverted) | Individual PWM (non-inverted) | V _{SS} or V _{DD} = PWMx/GRPPWM values |
| | 1 | 0 | off | Individual + Group PWM (inverted) | high-Z ^[2] or V _{SS} = (1 – PWMx) or (1 – GRPPWM) values |
| | 1 | 1 | Individual PWM (inverted) | Individual PWM (inverted) | V _{DD} or V _{SS} = (1 – PWMx) or (1 – GRPPWM) values |

[1] \overline{OE} applies to 16-pin version only. When $\overline{OE} = 1$, LED output state is controlled only by OUTNE[1:0] bits (MODE2 register).

[2] External pull-up or LED current limiting resistor connects LEDn to V_{DD}.

7.8 Individual brightness control with group dimming/blinking

A 97 kHz fixed frequency signal with programmable duty cycle (8 bits, 256 steps) is used to control individually the brightness for each LED.

On top of this signal, one of the following signals can be superimposed (this signal can be applied to the 4 LED outputs):

- A lower 190 Hz fixed frequency signal with programmable duty cycle (8 bits, 256 steps) is used to provide a global brightness control.
- A programmable frequency signal from 24 Hz to 1/10.73 Hz (8 bits, 256 steps) with programmable duty cycle (8 bits, 256 steps) is used to provide a global blinking control.

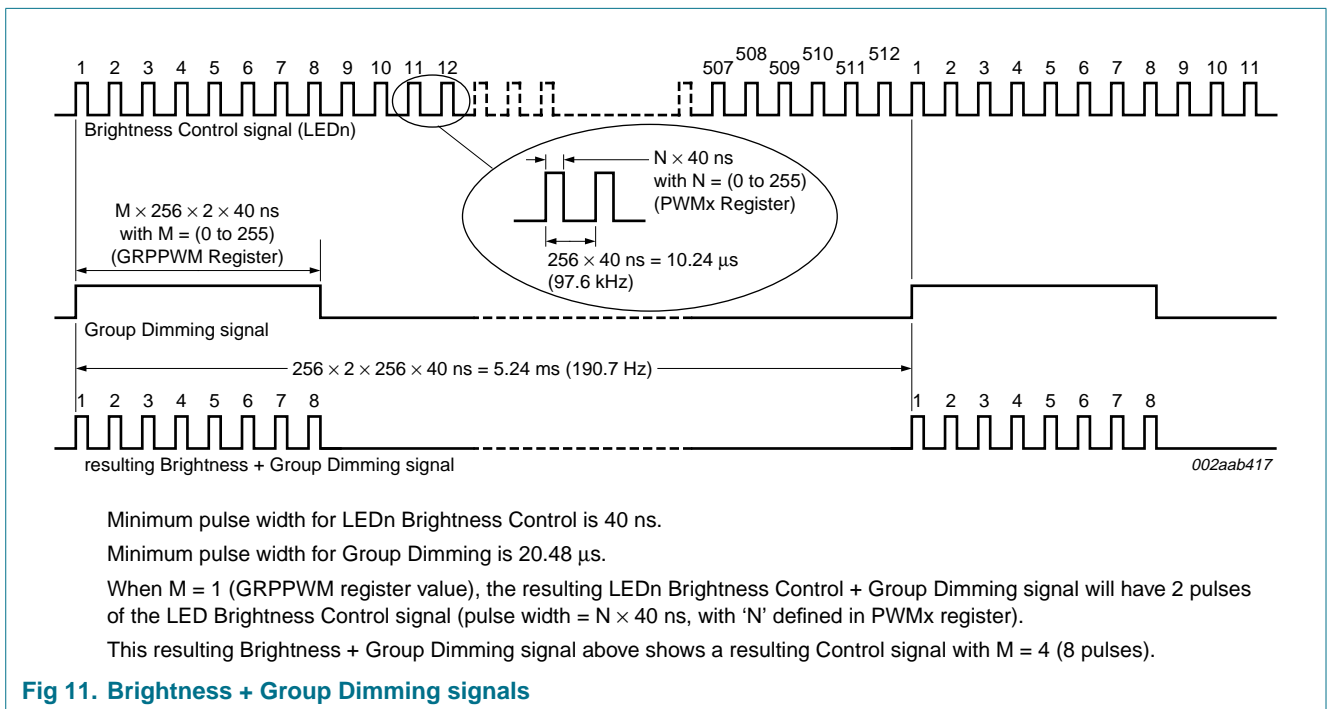

Fig 11. Brightness + Group Dimming signals

8. Characteristics of the I²C-bus

The I²C-bus is for 2-way, 2-line communication between different ICs or modules. The two lines are a serial data line (SDA) and a serial clock line (SCL). Both lines must be connected to a positive supply via a pull-up resistor when connected to the output stages of a device. Data transfer may be initiated only when the bus is not busy.

8.1 Bit transfer

One data bit is transferred during each clock pulse. The data on the SDA line must remain stable during the HIGH period of the clock pulse as changes in the data line at this time will be interpreted as control signals (see [Figure 12](#)).

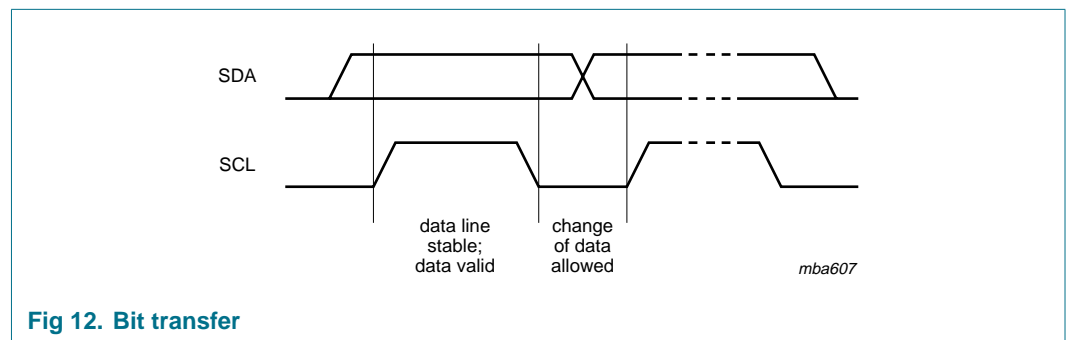

Fig 12. Bit transfer

8.1.1 START and STOP conditions

Both data and clock lines remain HIGH when the bus is not busy. A HIGH-to-LOW transition of the data line while the clock is HIGH is defined as the START condition (S). A LOW-to-HIGH transition of the data line while the clock is HIGH is defined as the STOP condition (P) (see [Figure 13](#)).

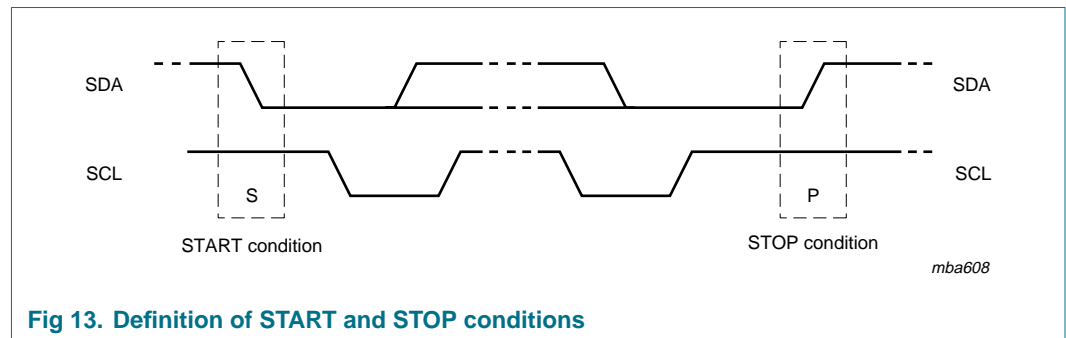

Fig 13. Definition of START and STOP conditions

8.2 System configuration

A device generating a message is a 'transmitter'; a device receiving is the 'receiver'. The device that controls the message is the 'master' and the devices which are controlled by the master are the 'slaves' (see [Figure 14](#)).

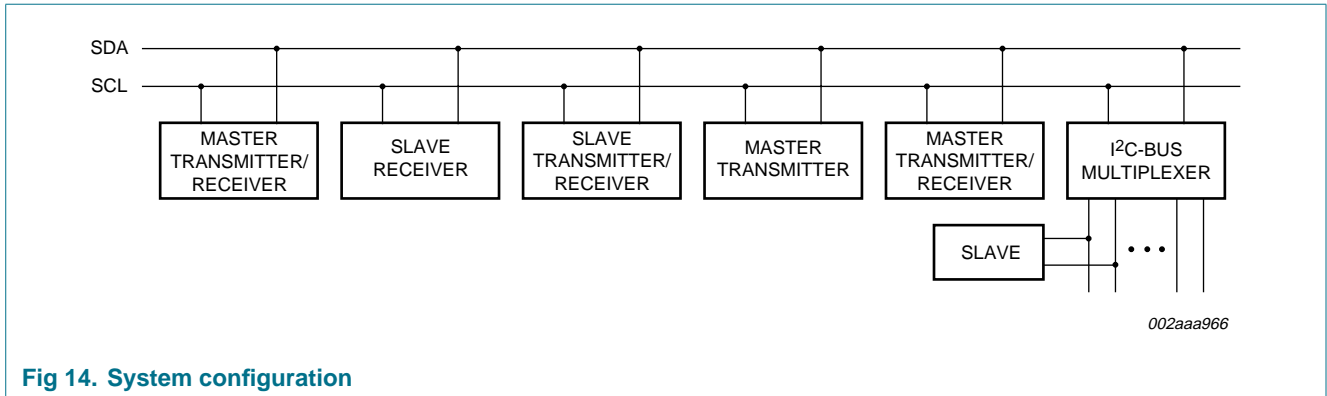

Fig 14. System configuration

8.3 Acknowledge

The number of data bytes transferred between the START and the STOP conditions from transmitter to receiver is not limited. Each byte of eight bits is followed by one acknowledge bit. The acknowledge bit is a HIGH level put on the bus by the transmitter, whereas the master generates an extra acknowledge related clock pulse.

A slave receiver which is addressed must generate an acknowledge after the reception of each byte. Also a master must generate an acknowledge after the reception of each byte that has been clocked out of the slave transmitter. The device that acknowledges has to pull down the SDA line during the acknowledge clock pulse, so that the SDA line is stable LOW during the HIGH period of the acknowledge related clock pulse; set-up time and hold time must be taken into account.

A master receiver must signal an end of data to the transmitter by not generating an acknowledge on the last byte that has been clocked out of the slave. In this event, the transmitter must leave the data line HIGH to enable the master to generate a STOP condition.

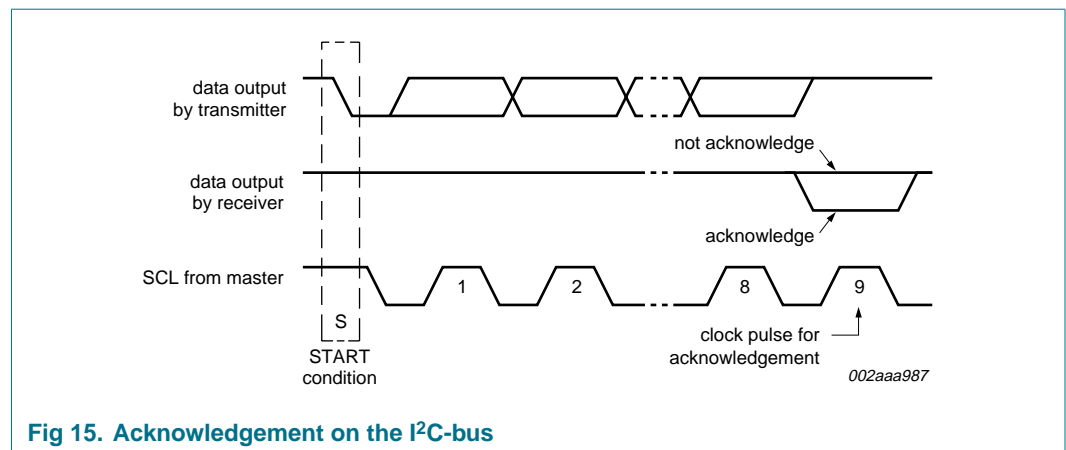
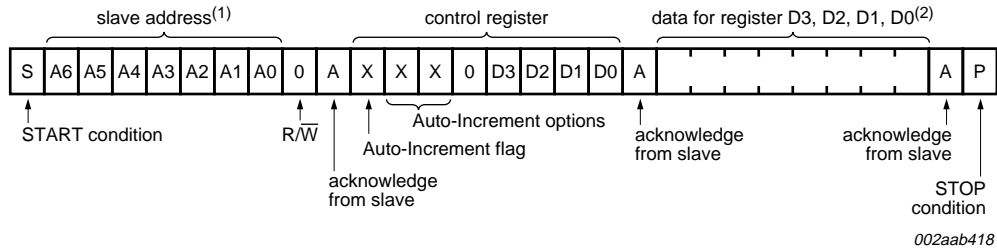

Fig 15. Acknowledgement on the I²C-bus

9. Bus transactions



- (1) 16-pin version only.
- (2) See [Table 7](#) for register definition.

Fig 16. Write to a specific register

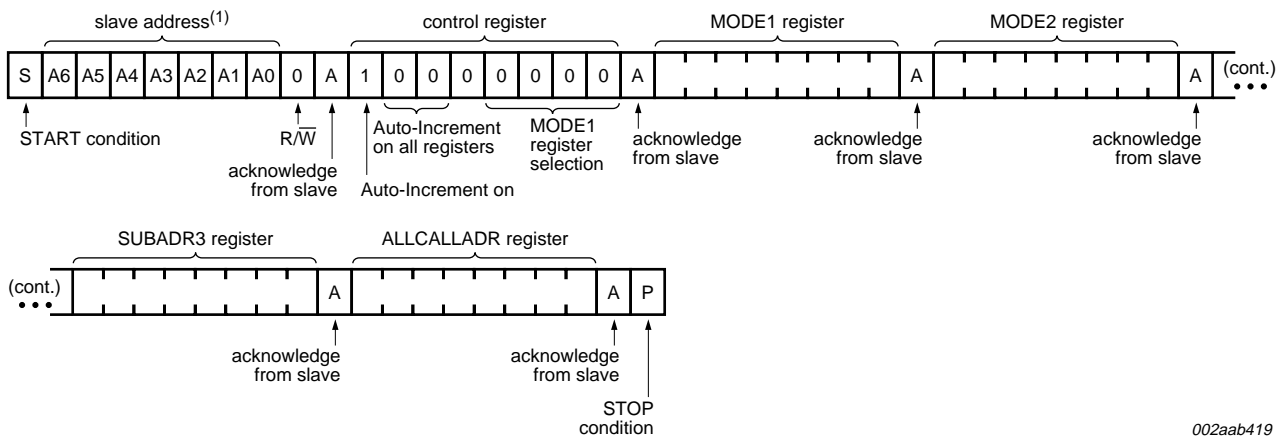

- (1) 16-pin version only.

Fig 17. Write to all registers using the Auto-Increment feature

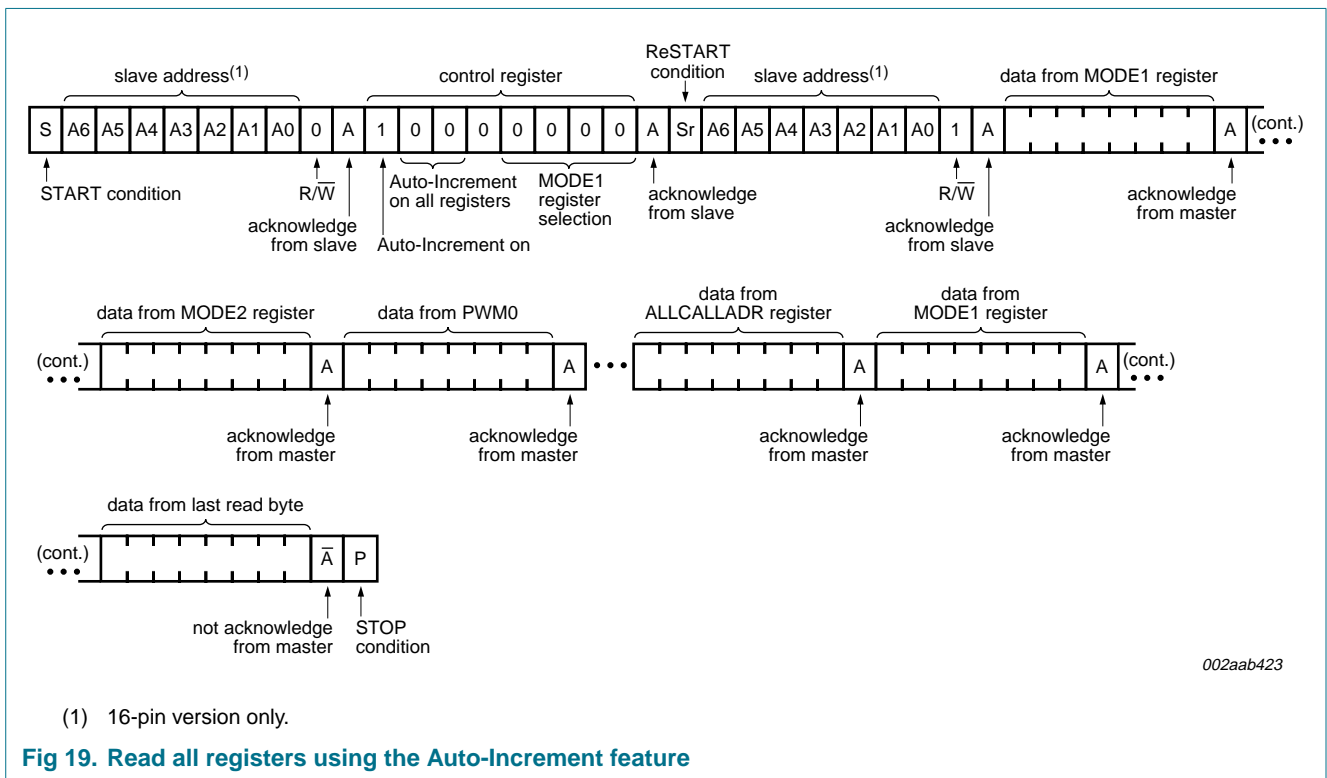
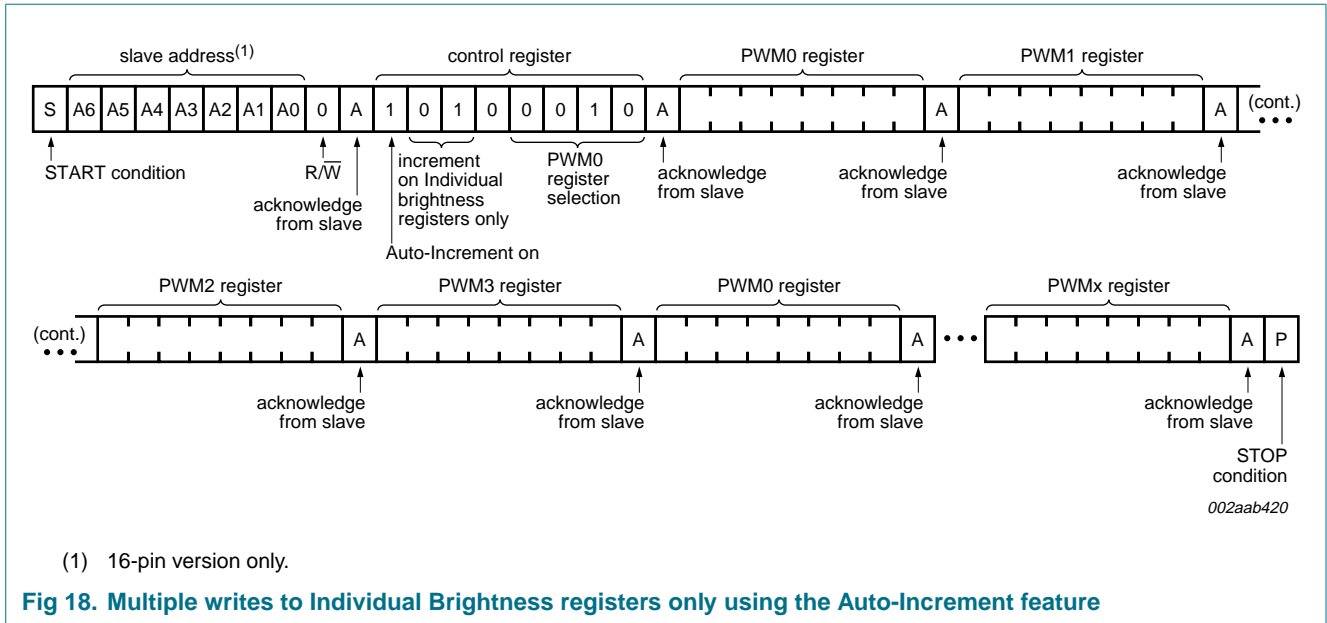

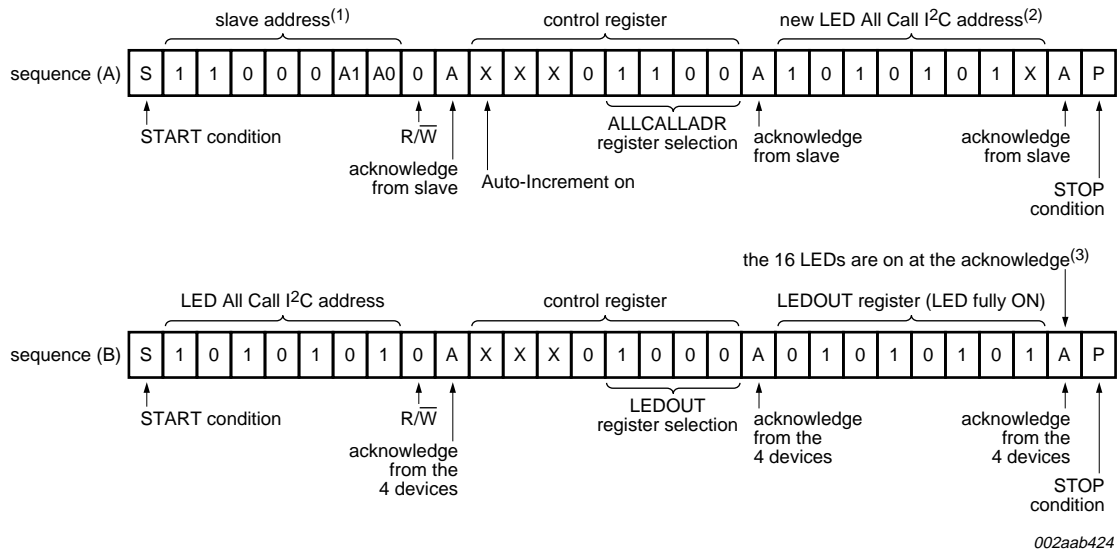

- (1) 10-pin version is used for this figure. Four PCA9633DP2 are used and the same sequence (A) (above) is sent to each of them. A[1:0] = 00 to 11.
- (2) ALLCALL bit in MODE1 register is equal to 1 for this example.
- (3) OCH bit in MODE2 register is equal to 1 for this example.

Fig 20. LED All Call I²C-bus address programming and LED All Call sequence example

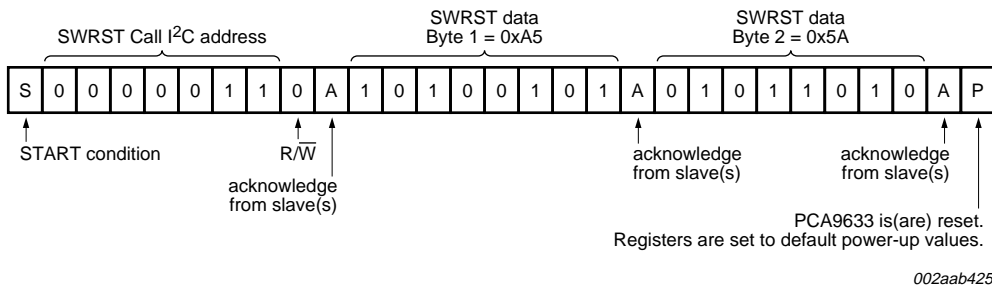
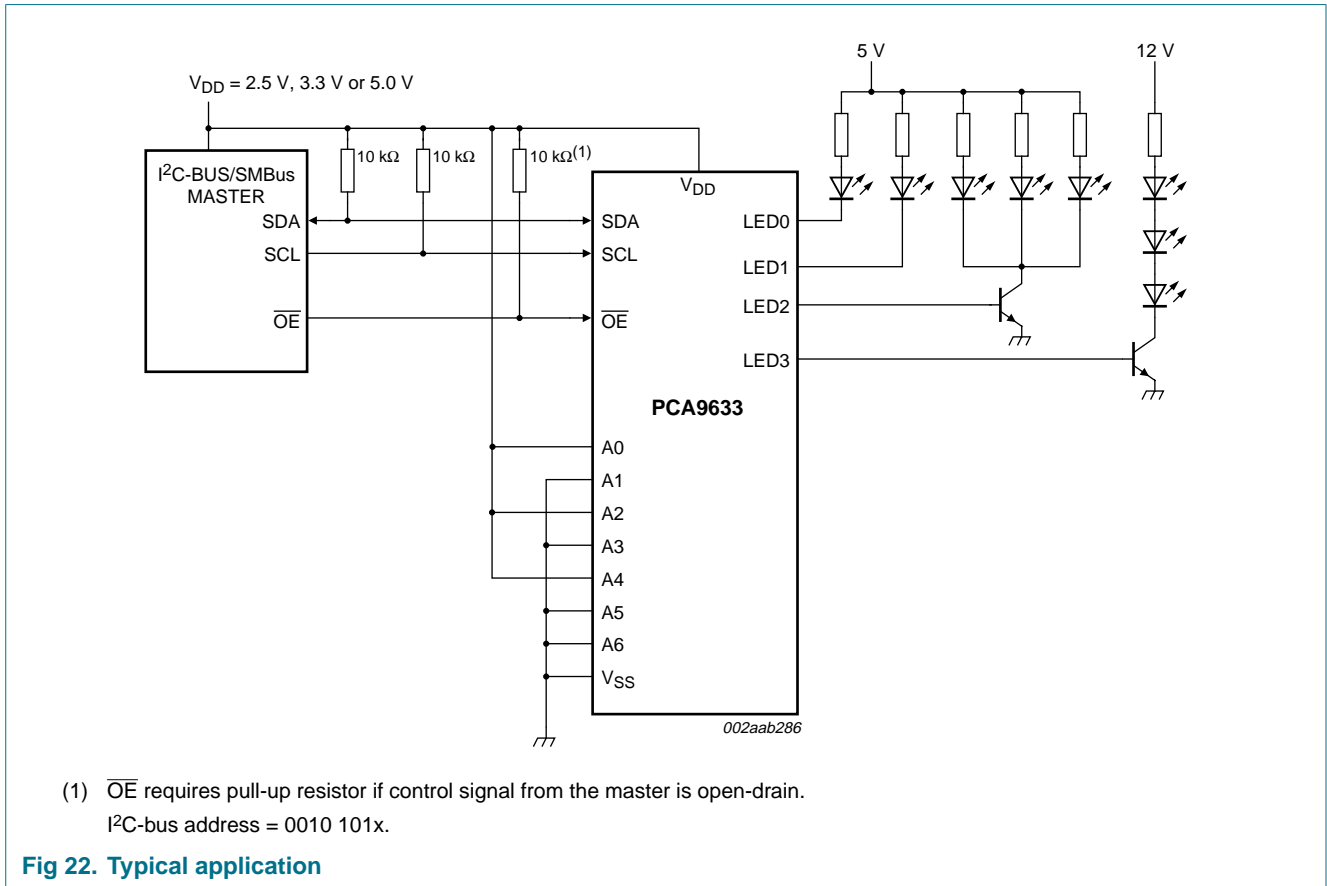

Fig 21. Software Reset (SWRST) Call sequence

10. Application design-in information



11. Limiting values

Table 19. Limiting values

In accordance with the Absolute Maximum Rating System (IEC 60134).

| Symbol | Parameter | Conditions | Min | Max | Unit |
|----------------------|--------------------------------|------------|-----------------------|------|------|
| V _{DD} | supply voltage | | -0.5 | +6.0 | V |
| V _{I/O} | voltage on an input/output pin | | V _{SS} - 0.5 | 5.5 | V |
| I _{O(LEDn)} | output current on pin LEDn | | - | 25 | mA |
| I _{SS} | ground supply current | | - | 100 | mA |
| P _{tot} | total power dissipation | | - | 400 | mW |
| T _{stg} | storage temperature | | -65 | +150 | °C |
| T _{amb} | ambient temperature | operating | -40 | +85 | °C |

12. Static characteristics

Table 20. Static characteristics
 $V_{DD} = 2.3\text{ V to }5.5\text{ V}; V_{SS} = 0\text{ V}; T_{amb} = -40\text{ }^{\circ}\text{C to }+85\text{ }^{\circ}\text{C};$ unless otherwise specified.

| Symbol | Parameter | Conditions | Min | Typ | Max | Unit | |
|------------------------------------|--------------------------------|---|--------------|-----|---------------|---------------|----|
| Supply | | | | | | | |
| V_{DD} | supply voltage | | 2.3 | - | 5.5 | V | |
| I_{DD} | supply current | operating mode; no load; $f_{SCL} = 1\text{ MHz}$ | | | | | |
| | | $V_{DD} = 2.3\text{ V}$ | - | 2.5 | 10 | mA | |
| | | $V_{DD} = 3.3\text{ V}$ | - | 2.5 | 10 | mA | |
| | | $V_{DD} = 5.5\text{ V}$ | - | 2.5 | 10 | mA | |
| I_{stb} | standby current | no load; $f_{SCL} = 0\text{ Hz}$; I/O = inputs; $V_I = V_{DD}$ | | | | | |
| | | $V_{DD} = 2.3\text{ V}$ | - | 2.3 | 11 | μA | |
| | | $V_{DD} = 3.3\text{ V}$ | - | 2.9 | 12 | μA | |
| | | $V_{DD} = 5.5\text{ V}$ | - | 3.8 | 15.5 | μA | |
| V_{POR} | power-on reset voltage | no load; $V_I = V_{DD}$ or V_{SS} | [1] | - | 1.70 | 2.0 | V |
| Input SCL; input/output SDA | | | | | | | |
| V_{IL} | LOW-level input voltage | | -0.5 | - | +0.3 V_{DD} | V | |
| V_{IH} | HIGH-level input voltage | | 0.7 V_{DD} | - | 5.5 | V | |
| I_{OL} | LOW-level output current | $V_{OL} = 0.4\text{ V}; V_{DD} = 2.3\text{ V}$ | 20 | - | - | mA | |
| | | $V_{OL} = 0.4\text{ V}; V_{DD} = 5.0\text{ V}$ | 30 | - | - | mA | |
| I_L | leakage current | $V_I = V_{DD}$ or V_{SS} | -1 | - | +1 | μA | |
| C_i | input capacitance | $V_I = V_{SS}$ | - | 6 | 10 | pF | |
| LED driver outputs | | | | | | | |
| I_{OL} | LOW-level output current | $V_{OL} = 0.5\text{ V}; V_{DD} = 2.3\text{ V}$ | [2] | 12 | - | - | mA |
| | | $V_{OL} = 0.5\text{ V}; V_{DD} = 3.0\text{ V}$ | [2] | 17 | - | - | mA |
| | | $V_{OL} = 0.5\text{ V}; V_{DD} = 4.5\text{ V}$ | [2] | 25 | - | - | mA |
| $I_{OL(tot)}$ | total LOW-level output current | $V_{OL} = 0.5\text{ V}; V_{DD} = 4.5\text{ V}$ | [2] | - | - | 100 | mA |
| I_{OH} | HIGH-level output current | open-drain; $V_{OH} = V_{DD}$ | -50 | - | +50 | μA | |
| V_{OH} | HIGH-level output voltage | $I_{OH} = -10\text{ mA}; V_{DD} = 2.3\text{ V}$ | 1.6 | - | - | V | |
| | | $I_{OH} = -10\text{ mA}; V_{DD} = 3.0\text{ V}$ | 2.3 | - | - | V | |
| | | $I_{OH} = -10\text{ mA}; V_{DD} = 4.5\text{ V}$ | 4.0 | - | - | V | |
| C_o | output capacitance | | - | 2.5 | 5 | pF | |
| OE input | | | | | | | |
| V_{IL} | LOW-level input voltage | | -0.5 | - | +0.8 | V | |
| V_{IH} | HIGH-level input voltage | | 2 | - | 5.5 | V | |
| I_{LI} | input leakage current | | -1 | - | +1 | μA | |
| C_i | input capacitance | | - | 3.7 | 5 | pF | |

Table 20. Static characteristics ...continued
 $V_{DD} = 2.3\text{ V to }5.5\text{ V}$; $V_{SS} = 0\text{ V}$; $T_{amb} = -40\text{ }^{\circ}\text{C to }+85\text{ }^{\circ}\text{C}$; unless otherwise specified.

| Symbol | Parameter | Conditions | Min | Typ | Max | Unit |
|-----------------------|--------------------------|------------|--------------|-----|---------------|---------------|
| Address inputs | | | | | | |
| V_{IL} | LOW-level input voltage | | -0.5 | - | +0.3 V_{DD} | V |
| V_{IH} | HIGH-level input voltage | | 0.7 V_{DD} | - | 5.5 | V |
| I_{LI} | input leakage current | | -1 | - | +1 | μA |
| C_i | input capacitance | | - | 3.7 | 5 | pF |

- [1] V_{DD} must be lowered to 0.2 V in order to reset part.
- [2] Each bit must be limited to a maximum of 25 mA and the total package limited to 100 mA due to internal busing limits.

13. Dynamic characteristics

Table 21. Dynamic characteristics

| Symbol | Parameter | Conditions | Standard- mode I ² C-bus | | Fast-mode I ² C-bus | | Fast-mode Plus I ² C-bus | | Unit |
|--------------|---|------------|-------------------------------------|------|--------------------------------|-----|-------------------------------------|------|---------------|
| | | | Min | Max | Min | Max | Min | Max | |
| f_{SCL} | SCL clock frequency | [1] | 0 | 100 | 0 | 400 | 0 | 1000 | kHz |
| t_{BUF} | bus free time between a STOP and START condition | | 4.7 | - | 1.3 | - | 0.5 | - | μs |
| $t_{HD;STA}$ | hold time (repeated) START condition | | 4.0 | - | 0.6 | - | 0.26 | - | μs |
| $t_{SU;STA}$ | set-up time for a repeated START condition | | 4.7 | - | 0.6 | - | 0.26 | - | μs |
| $t_{SU;STO}$ | set-up time for STOP condition | | 4.0 | - | 0.6 | - | 0.26 | - | μs |
| $t_{HD;DAT}$ | data hold time | | 0 | - | 0 | - | 0 | - | ns |
| $t_{VD;ACK}$ | data valid acknowledge time | [2] | 0.3 | 3.45 | 0.1 | 0.9 | 0.05 | 0.45 | μs |
| $t_{VD;DAT}$ | data valid time | [3] | 0.3 | 3.45 | 0.1 | 0.9 | 0.05 | 0.45 | μs |
| $t_{SU;DAT}$ | data set-up time | | 250 | - | 100 | - | 50 | - | ns |
| t_{LOW} | LOW period of the SCL clock | | 4.7 | - | 1.3 | - | 0.5 | - | μs |
| t_{HIGH} | HIGH period of the SCL clock | | 4.0 | - | 0.6 | - | 0.26 | - | μs |
| t_f | fall time of both SDA and SCL signals | [5][6] | - | 300 | $20 + 0.1C_b$ [4] | 300 | - | 120 | ns |
| t_r | rise time of both SDA and SCL signals | | - | 1000 | $20 + 0.1C_b$ [4] | 300 | - | 120 | ns |
| t_{SP} | pulse width of spikes that must be suppressed by the input filter | [7] | - | 50 | - | 50 | - | 50 | ns |

- [1] Minimum SCL clock frequency is limited by the bus time-out feature, which resets the serial bus interface if either SDA or SCL is held LOW for a minimum of 25 ms. Disable bus time-out feature for DC operation.
- [2] $t_{VD;ACK}$ = time for Acknowledgement signal from SCL LOW to SDA (out) LOW.
- [3] $t_{VD;DAT}$ = minimum time for SDA data out to be valid following SCL LOW.
- [4] C_b = total capacitance of one bus line in pF.

- [5] A master device must internally provide a hold time of at least 300 ns for the SDA signal (refer to the V_{IL} of the SCL signal) in order to bridge the undefined region of SCL's falling edge.
- [6] The maximum t_r for the SDA and SCL bus lines is specified at 300 ns. The maximum fall time (t_f) for the SDA output stage is specified at 250 ns. This allows series protection resistors to be connected between the SDA and the SCL pins and the SDA/SCL bus lines without exceeding the maximum specified t_r .
- [7] Input filters on the SDA and SCL inputs suppress noise spikes less than 50 ns.

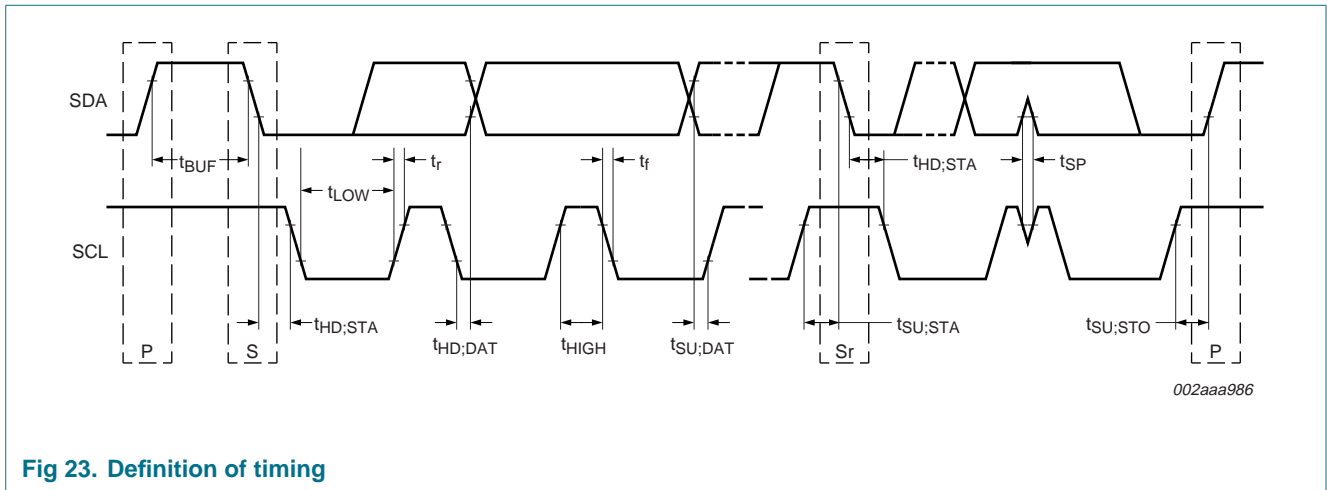

Fig 23. Definition of timing

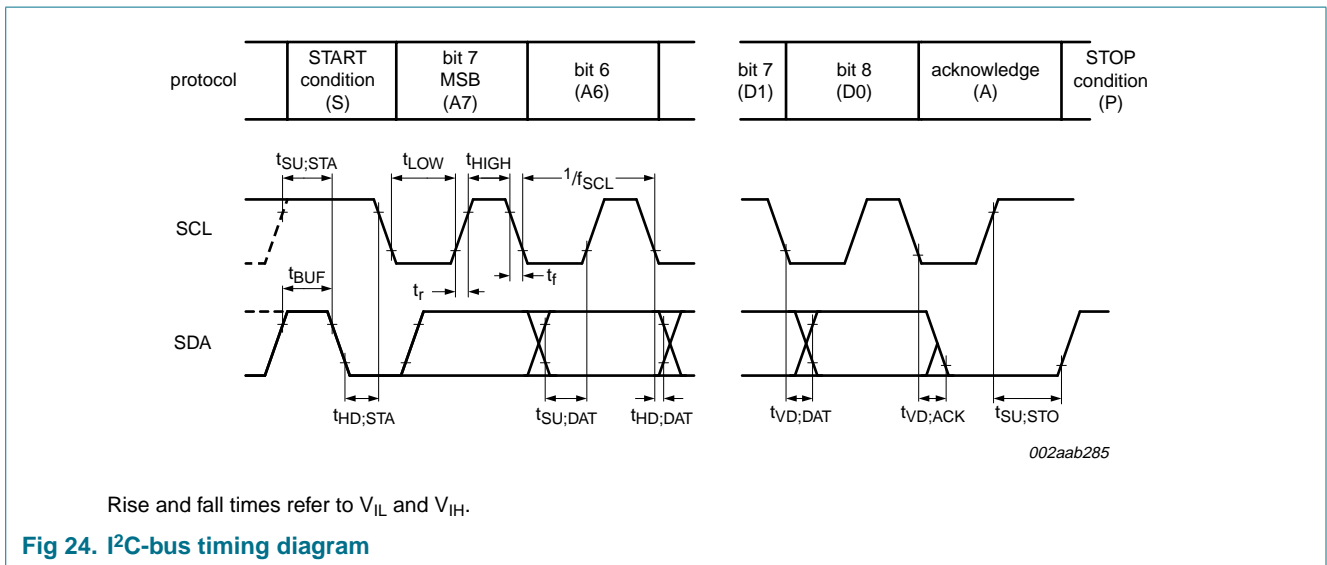
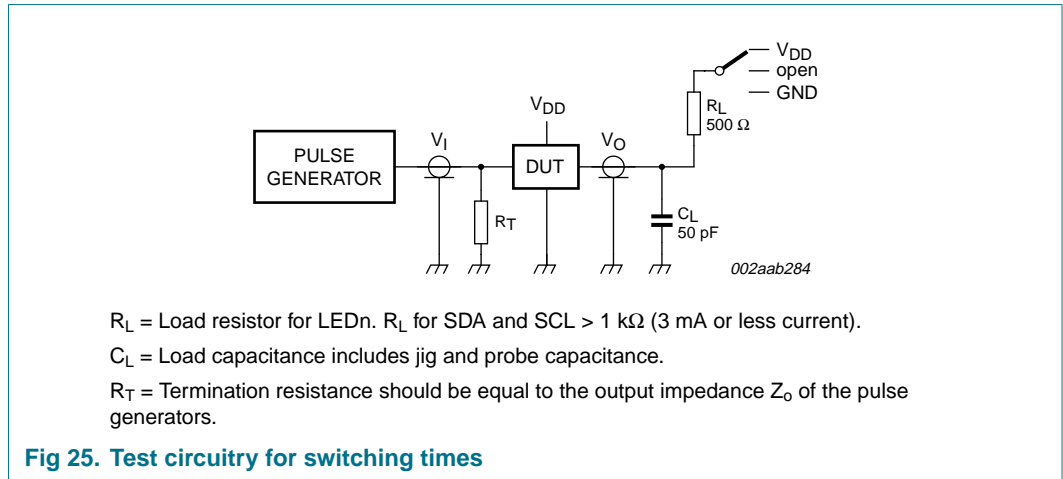

Fig 24. I²C-bus timing diagram

14. Test information



15. Package outline

SO16: plastic small outline package; 16 leads; body width 3.9 mm

SOT109-1

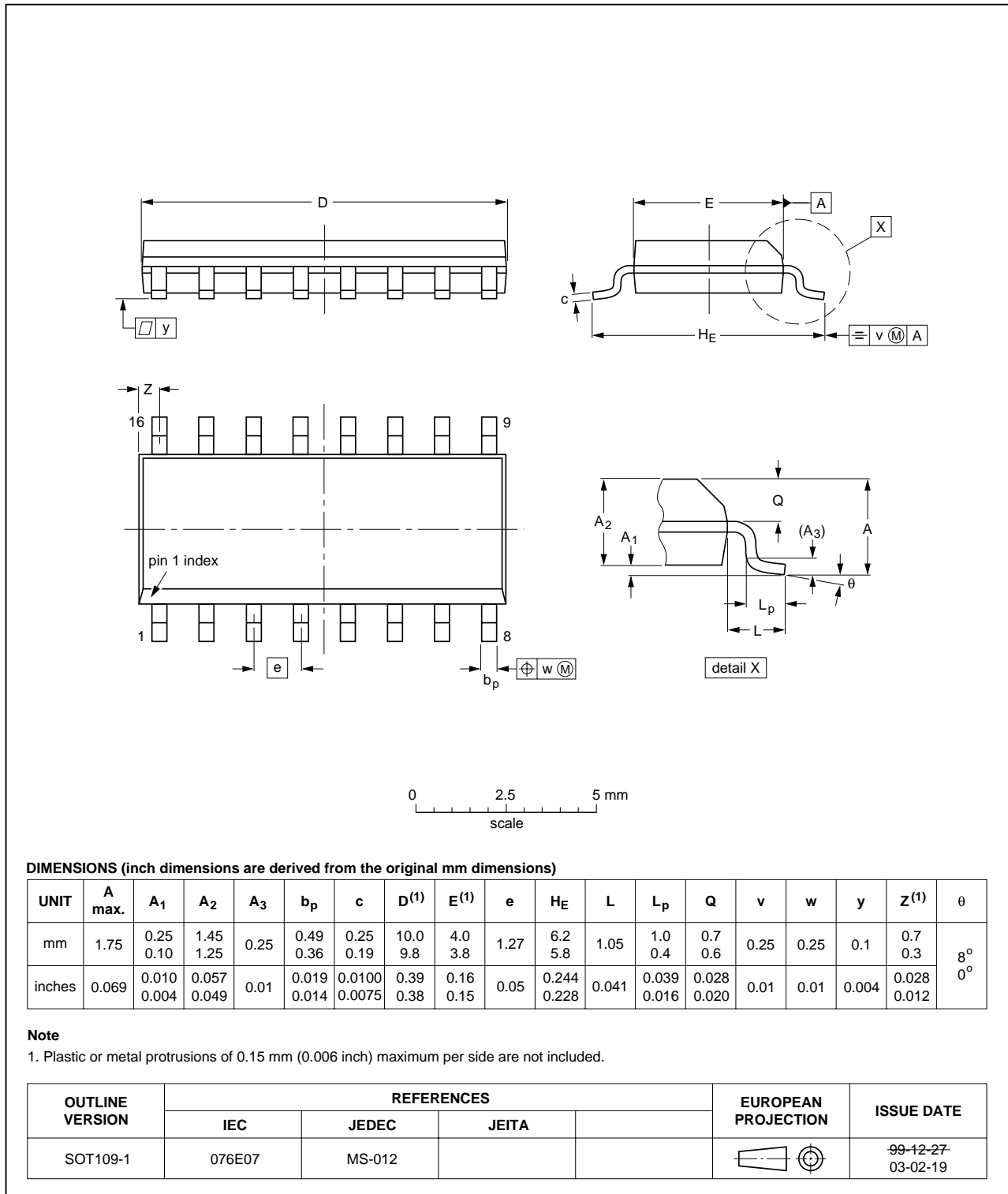

Fig 26. Package outline SOT109-1 (SO16)

TSSOP8: plastic thin shrink small outline package; 8 leads; body width 3 mm

SOT505-1

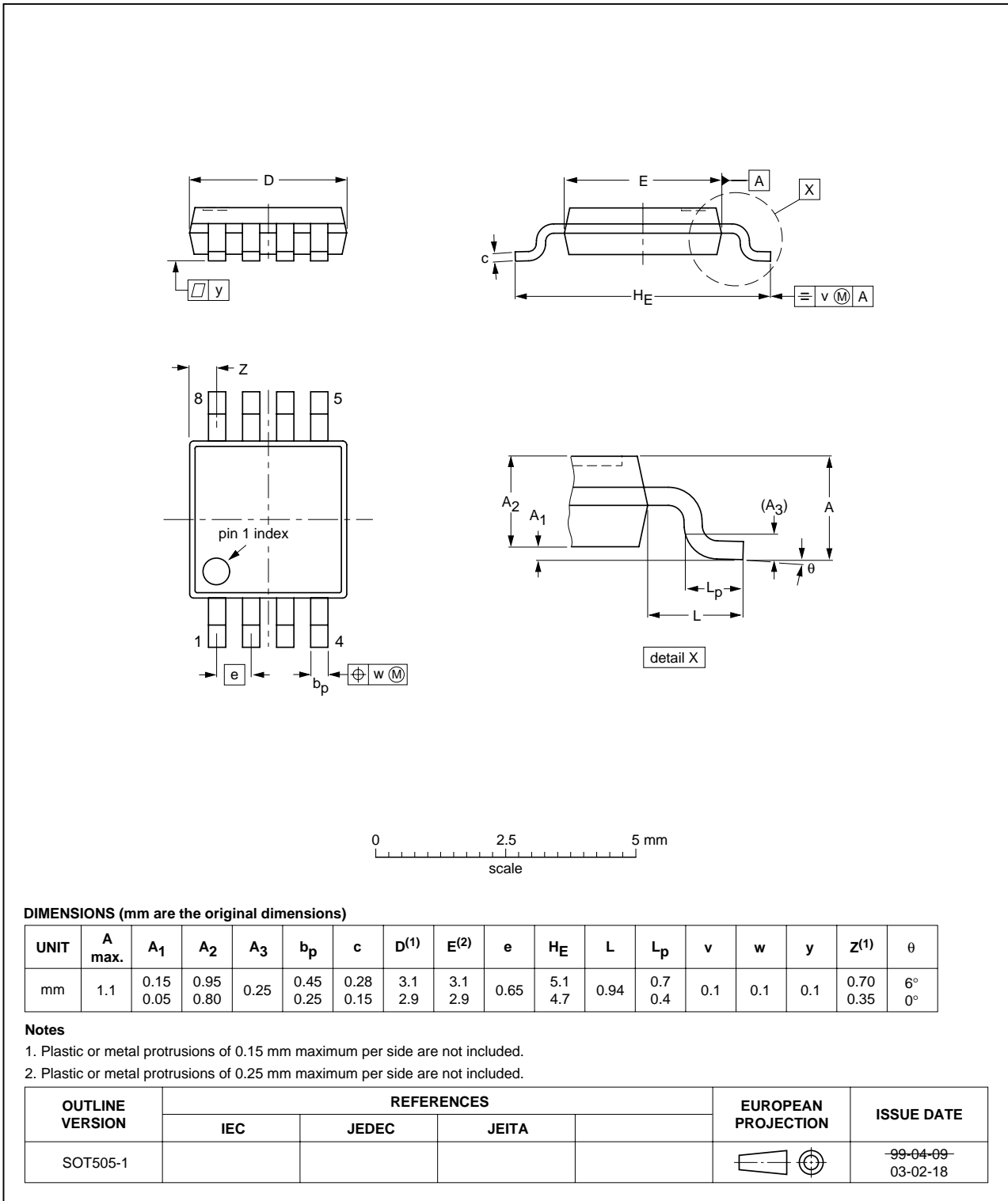

Fig 27. Package outline SOT505-1 (TSSOP8)

TSSOP10: plastic thin shrink small outline package; 10 leads; body width 3 mm

SOT552-1

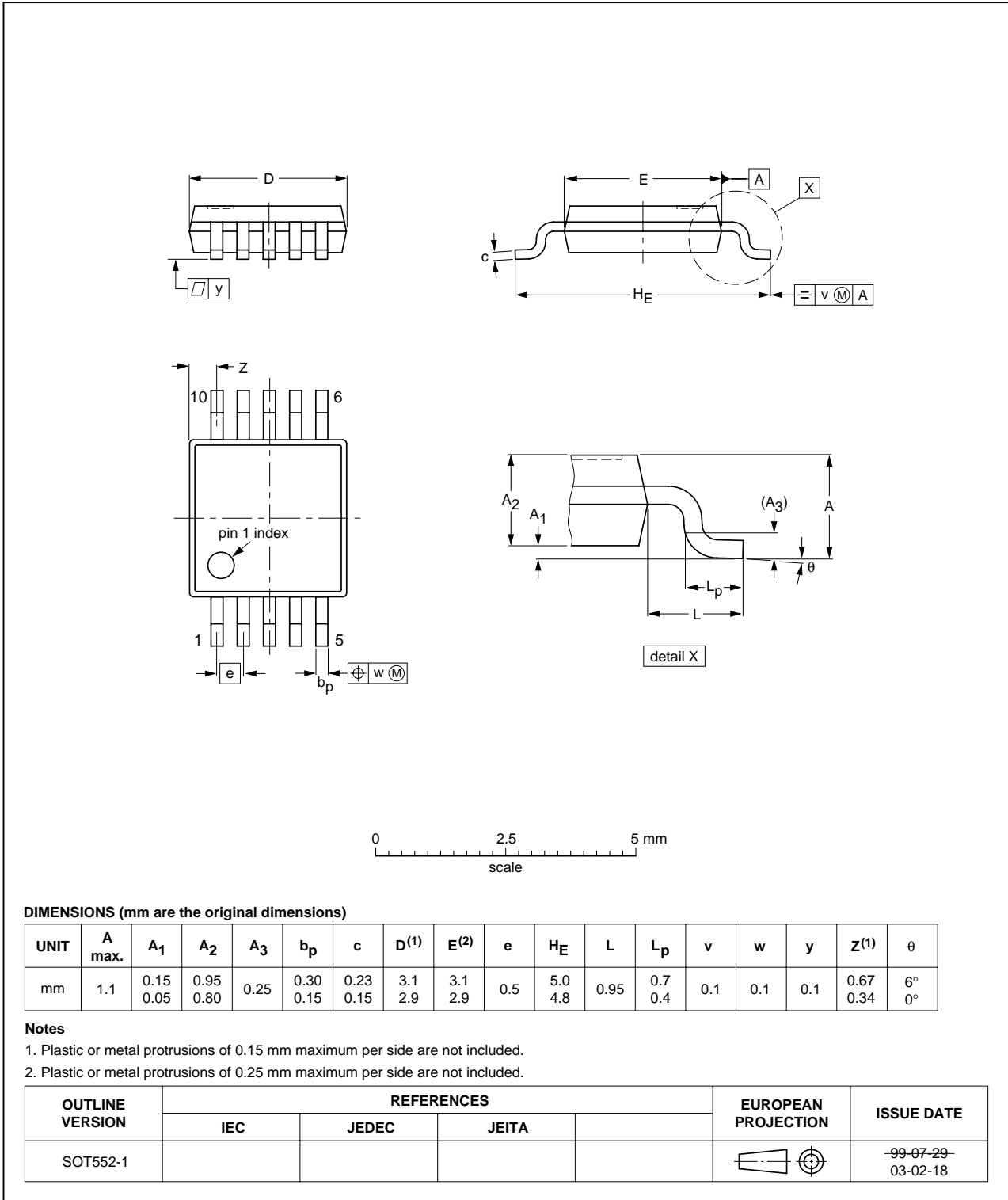

Fig 28. Package outline SOT552-1 (TSSOP10)

TSSOP16: plastic thin shrink small outline package; 16 leads; body width 4.4 mm

SOT403-1

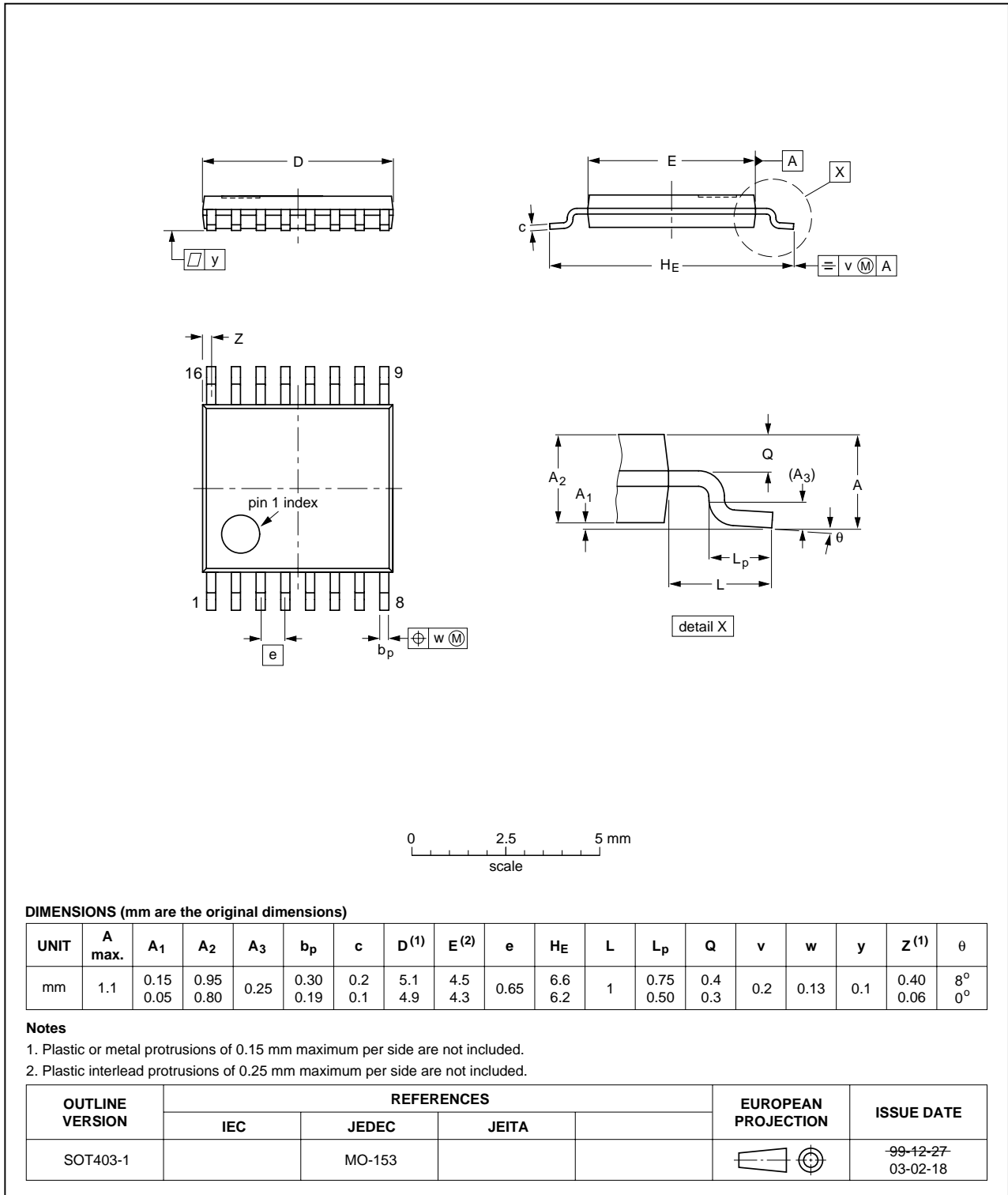

Fig 29. Package outline SOT403-1 (TSSOP16)

HVQFN16: plastic thermal enhanced very thin quad flat package; no leads; 16 terminals; body 4 x 4 x 0.85 mm

SOT629-1

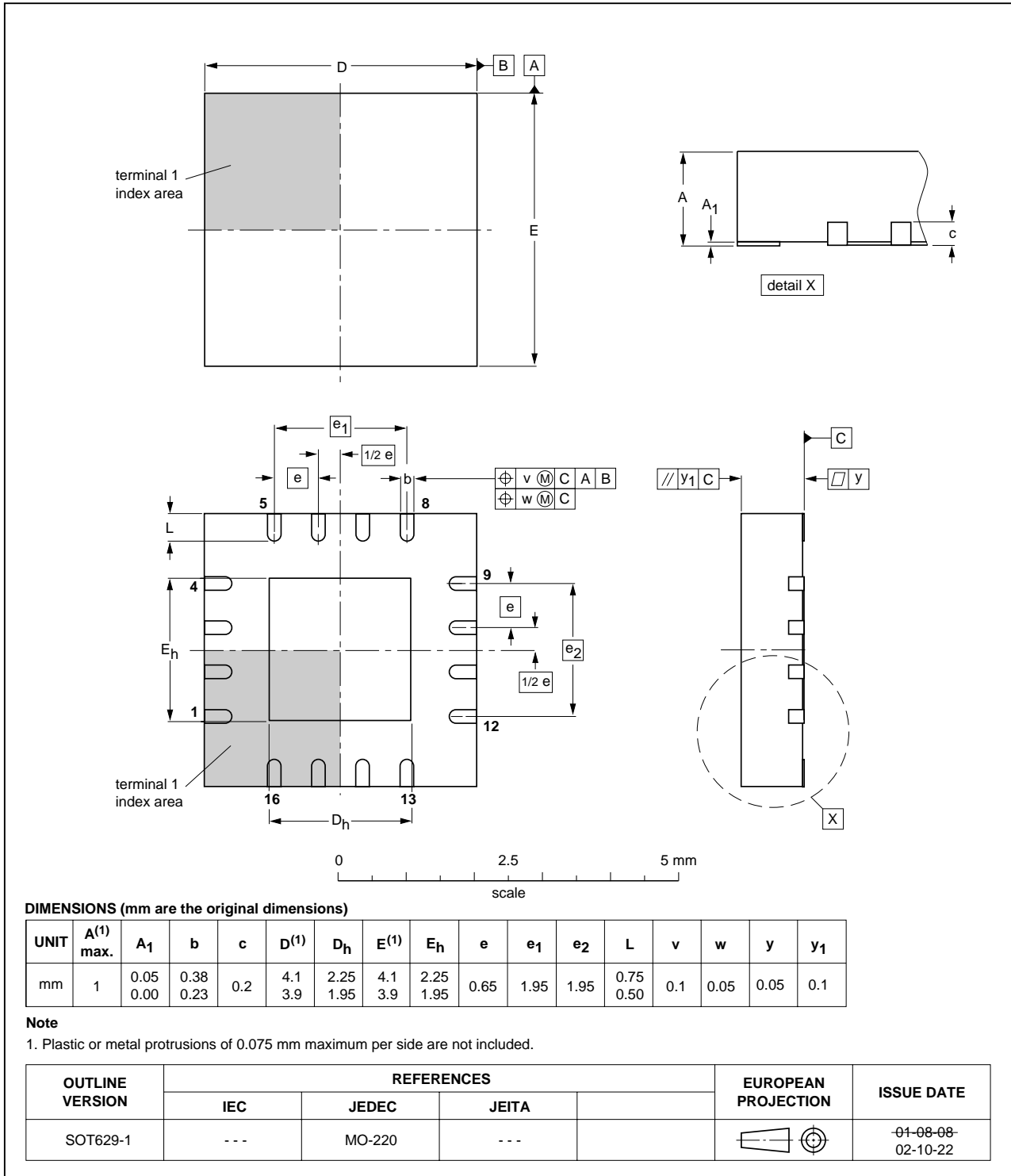

Fig 30. Package outline SOT629-1 (HVQFN16)

HVSON8: plastic thermal enhanced very thin small outline package; no leads;
8 terminals; body 3 x 3 x 0.85 mm

SOT908-1

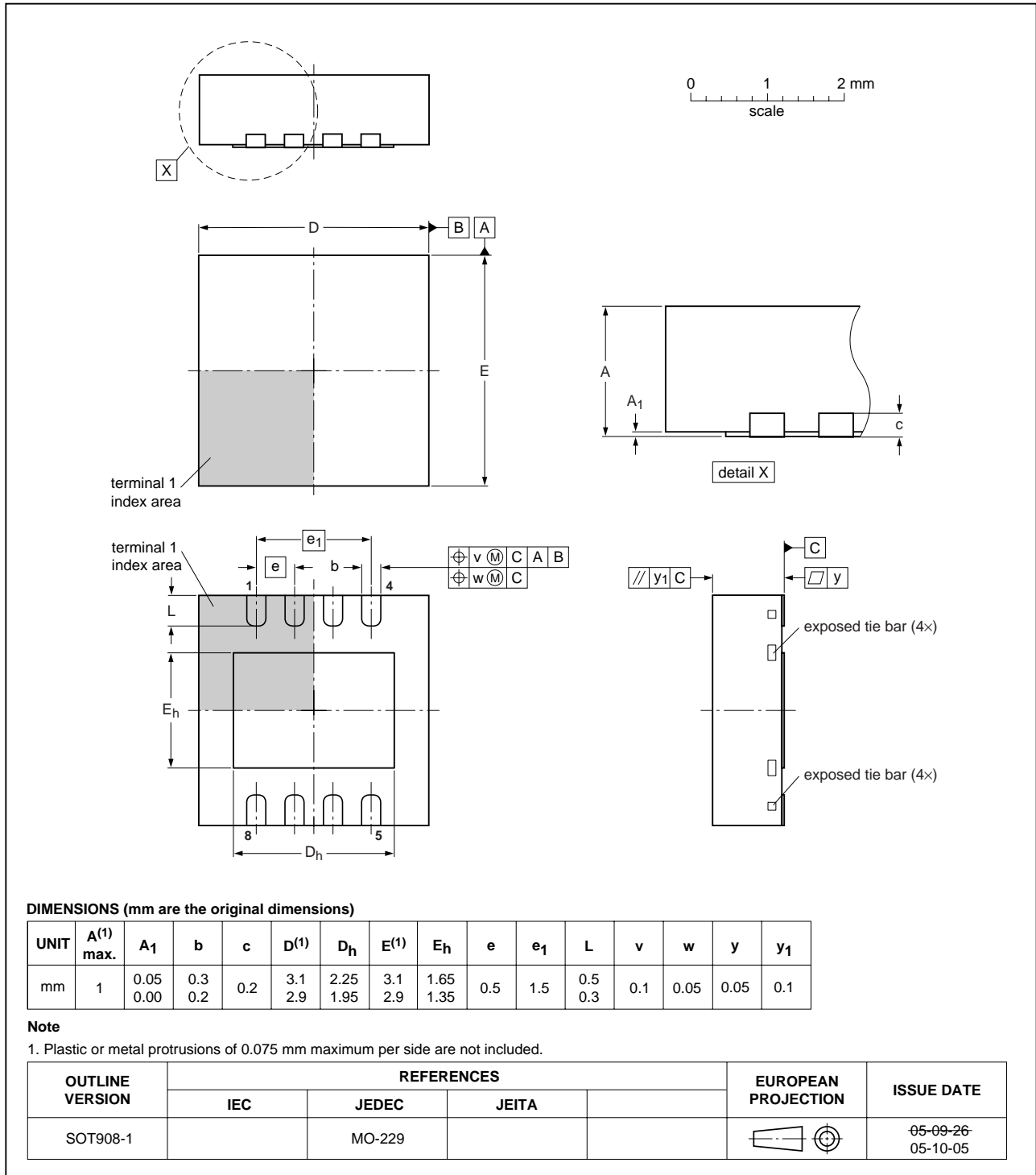

Fig 31. Package outline SOT908-1 (HVSON8)

16. Handling information

Inputs and outputs are protected against electrostatic discharge in normal handling. However, to be completely safe you must take normal precautions appropriate to handling integrated circuits.

17. Soldering

This text provides a very brief insight into a complex technology. A more in-depth account of soldering ICs can be found in Application Note *AN10365 "Surface mount reflow soldering description"*.

17.1 Introduction to soldering

Soldering is one of the most common methods through which packages are attached to Printed Circuit Boards (PCBs), to form electrical circuits. The soldered joint provides both the mechanical and the electrical connection. There is no single soldering method that is ideal for all IC packages. Wave soldering is often preferred when through-hole and Surface Mount Devices (SMDs) are mixed on one printed wiring board; however, it is not suitable for fine pitch SMDs. Reflow soldering is ideal for the small pitches and high densities that come with increased miniaturization.

17.2 Wave and reflow soldering

Wave soldering is a joining technology in which the joints are made by solder coming from a standing wave of liquid solder. The wave soldering process is suitable for the following:

- Through-hole components
- Leaded or leadless SMDs, which are glued to the surface of the printed circuit board

Not all SMDs can be wave soldered. Packages with solder balls, and some leadless packages which have solder lands underneath the body, cannot be wave soldered. Also, leaded SMDs with leads having a pitch smaller than ~0.6 mm cannot be wave soldered, due to an increased probability of bridging.

The reflow soldering process involves applying solder paste to a board, followed by component placement and exposure to a temperature profile. Leaded packages, packages with solder balls, and leadless packages are all reflow solderable.

Key characteristics in both wave and reflow soldering are:

- Board specifications, including the board finish, solder masks and vias
- Package footprints, including solder thieves and orientation
- The moisture sensitivity level of the packages
- Package placement
- Inspection and repair
- Lead-free soldering versus PbSn soldering

17.3 Wave soldering

Key characteristics in wave soldering are:

- Process issues, such as application of adhesive and flux, clinching of leads, board transport, the solder wave parameters, and the time during which components are exposed to the wave
- Solder bath specifications, including temperature and impurities

17.4 Reflow soldering

Key characteristics in reflow soldering are:

- Lead-free versus SnPb soldering; note that a lead-free reflow process usually leads to higher minimum peak temperatures (see [Figure 32](#)) than a PbSn process, thus reducing the process window
- Solder paste printing issues including smearing, release, and adjusting the process window for a mix of large and small components on one board
- Reflow temperature profile; this profile includes preheat, reflow (in which the board is heated to the peak temperature) and cooling down. It is imperative that the peak temperature is high enough for the solder to make reliable solder joints (a solder paste characteristic). In addition, the peak temperature must be low enough that the packages and/or boards are not damaged. The peak temperature of the package depends on package thickness and volume and is classified in accordance with [Table 22](#) and [23](#)

Table 22. SnPb eutectic process (from J-STD-020C)

| Package thickness (mm) | Package reflow temperature (°C) | |
|------------------------|---------------------------------|-------|
| | Volume (mm ³) | |
| | < 350 | ≥ 350 |
| < 2.5 | 235 | 220 |
| ≥ 2.5 | 220 | 220 |

Table 23. Lead-free process (from J-STD-020C)

| Package thickness (mm) | Package reflow temperature (°C) | | |
|------------------------|---------------------------------|-------------|--------|
| | Volume (mm ³) | | |
| | < 350 | 350 to 2000 | > 2000 |
| < 1.6 | 260 | 260 | 260 |
| 1.6 to 2.5 | 260 | 250 | 245 |
| > 2.5 | 250 | 245 | 245 |

Moisture sensitivity precautions, as indicated on the packing, must be respected at all times.

Studies have shown that small packages reach higher temperatures during reflow soldering, see [Figure 32](#).

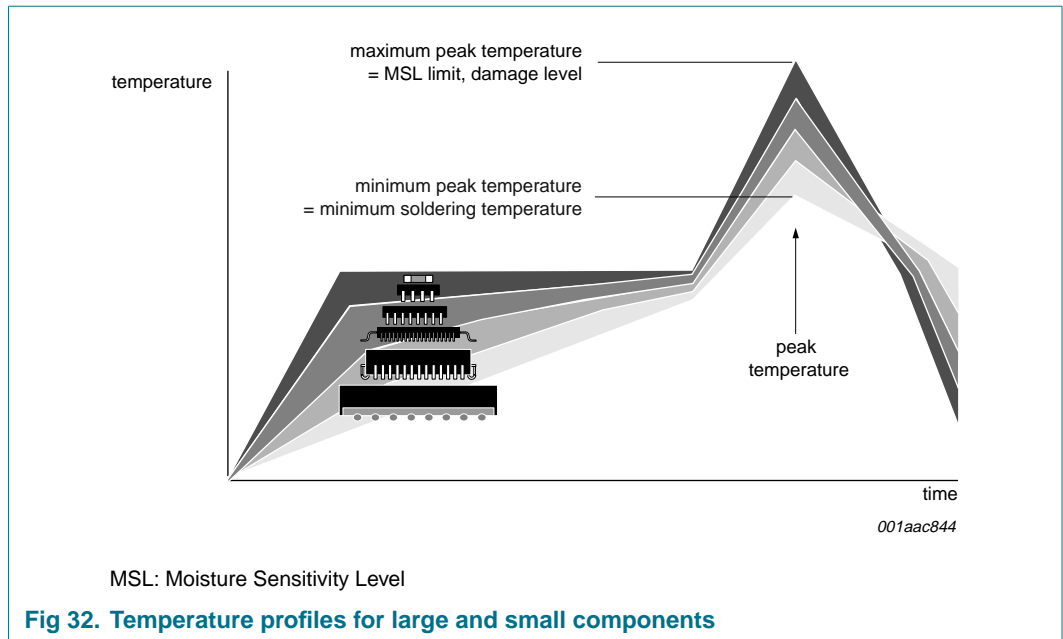

For further information on temperature profiles, refer to Application Note AN10365 “Surface mount reflow soldering description”.

18. Abbreviations

Table 24. Abbreviations

| Acronym | Description |
|----------------------|--|
| CDM | Charged Device Model |
| DUT | Device Under Test |
| ESD | ElectroStatic Discharge |
| HBM | Human Body Model |
| I ² C-bus | Inter-Integrated Circuit bus |
| LCD | Liquid Crystal Display |
| LED | Light Emitting Diode |
| LSB | Least Significant Bit |
| MM | Machine Model |
| MSB | Most Significant Bit |
| NMOS | Negative-channel Metal Oxide Semiconductor |
| PCB | Printed-Circuit Board |
| PMOS | Positive-channel Metal Oxide Semiconductor |
| PWM | Pulse Width Modulation |
| RGB | Red/Green/Blue |
| RGBA | Red/Green/Blue/Amber |
| SMBus | System Management Bus |

19. Revision history

Table 25. Revision history

| Document ID | Release date | Data sheet status | Change notice | Supersedes |
|-------------------------------|--|--------------------|---------------|------------|
| PCA9633_3 | 20061220 | Product data sheet | - | PCA9633_2 |
| Modifications: | <ul style="list-style-type: none"> • Section 1 "General description": <ul style="list-style-type: none"> – 2nd paragraph, last sentence: changed "... larger current LEDs or higher voltage LED strings." to "... larger current or higher voltage LEDs. – 3rd paragraph, 2nd sentence: changed "... and longer more densely populated ..." to "and more densely populated ..." • Section 2 "Features", 9th bullet item: changed "... and 127 PCA9633 devices" to "... and 126 PCA9633 devices" • Section 3 "Applications": deleted (old) second bullet item • Section 7.1 "Device addresses": added new 2nd paragraph • Deleted (old) Section 10.1, Section 20.4, and Section 20.5 | | | |
| PCA9633_2 | 20061114 | Product data sheet | - | PCA9633_1 |
| PCA9633_1 (9397 750 14614) | 20060123 | Product data sheet | - | - |

20. Legal information

20.1 Data sheet status

| Document status ^{[1][2]} | Product status ^[3] | Definition |
|-----------------------------------|-------------------------------|---|
| Objective [short] data sheet | Development | This document contains data from the objective specification for product development. |
| Preliminary [short] data sheet | Qualification | This document contains data from the preliminary specification. |
| Product [short] data sheet | Production | This document contains the product specification. |

[1] Please consult the most recently issued document before initiating or completing a design.

[2] The term 'short data sheet' is explained in section "Definitions".

[3] The product status of device(s) described in this document may have changed since this document was published and may differ in case of multiple devices. The latest product status information is available on the Internet at URL <http://www.nxp.com>.

20.2 Definitions

Draft — The document is a draft version only. The content is still under internal review and subject to formal approval, which may result in modifications or additions. NXP Semiconductors does not give any representations or warranties as to the accuracy or completeness of information included herein and shall have no liability for the consequences of use of such information.

Short data sheet — A short data sheet is an extract from a full data sheet with the same product type number(s) and title. A short data sheet is intended for quick reference only and should not be relied upon to contain detailed and full information. For detailed and full information see the relevant full data sheet, which is available on request via the local NXP Semiconductors sales office. In case of any inconsistency or conflict with the short data sheet, the full data sheet shall prevail.

20.3 Disclaimers

General — Information in this document is believed to be accurate and reliable. However, NXP Semiconductors does not give any representations or warranties, expressed or implied, as to the accuracy or completeness of such information and shall have no liability for the consequences of use of such information.

Right to make changes — NXP Semiconductors reserves the right to make changes to information published in this document, including without limitation specifications and product descriptions, at any time and without notice. This document supersedes and replaces all information supplied prior to the publication hereof.

Suitability for use — NXP Semiconductors products are not designed, authorized or warranted to be suitable for use in medical, military, aircraft, space or life support equipment, nor in applications where failure or malfunction of a NXP Semiconductors product can reasonably be expected to

result in personal injury, death or severe property or environmental damage. NXP Semiconductors accepts no liability for inclusion and/or use of NXP Semiconductors products in such equipment or applications and therefore such inclusion and/or use is at the customer's own risk.

Applications — Applications that are described herein for any of these products are for illustrative purposes only. NXP Semiconductors makes no representation or warranty that such applications will be suitable for the specified use without further testing or modification.

Limiting values — Stress above one or more limiting values (as defined in the Absolute Maximum Ratings System of IEC 60134) may cause permanent damage to the device. Limiting values are stress ratings only and operation of the device at these or any other conditions above those given in the Characteristics sections of this document is not implied. Exposure to limiting values for extended periods may affect device reliability.

Terms and conditions of sale — NXP Semiconductors products are sold subject to the general terms and conditions of commercial sale, as published at <http://www.nxp.com/profile/terms>, including those pertaining to warranty, intellectual property rights infringement and limitation of liability, unless explicitly otherwise agreed to in writing by NXP Semiconductors. In case of any inconsistency or conflict between information in this document and such terms and conditions, the latter will prevail.

No offer to sell or license — Nothing in this document may be interpreted or construed as an offer to sell products that is open for acceptance or the grant, conveyance or implication of any license under any copyrights, patents or other industrial or intellectual property rights.

20.4 Trademarks

Notice: All referenced brands, product names, service names and trademarks are the property of their respective owners.

I²C-bus — logo is a trademark of NXP B.V.

21. Contact information

For additional information, please visit: <http://www.nxp.com>

For sales office addresses, send an email to: salesaddresses@nxp.com

22. Contents

| | | | | | |
|-----------|---|-----------|-----------|--------------------------------------|-----------|
| 1 | General description | 1 | 17 | Soldering | 37 |
| 2 | Features | 2 | 17.1 | Introduction to soldering | 37 |
| 3 | Applications | 3 | 17.2 | Wave and reflow soldering | 37 |
| 4 | Ordering information | 3 | 17.3 | Wave soldering | 37 |
| 5 | Block diagram | 4 | 17.4 | Reflow soldering | 38 |
| 6 | Pinning information | 5 | 18 | Abbreviations | 39 |
| 6.1 | Pinning | 5 | 19 | Revision history | 40 |
| 6.2 | Pin description | 6 | 20 | Legal information | 41 |
| 7 | Functional description | 8 | 20.1 | Data sheet status | 41 |
| 7.1 | Device addresses | 8 | 20.2 | Definitions | 41 |
| 7.1.1 | Regular I ² C-bus slave address | 8 | 20.3 | Disclaimers | 41 |
| 7.1.2 | LED All Call I ² C-bus address | 8 | 20.4 | Trademarks | 41 |
| 7.1.3 | LED Sub Call I ² C-bus addresses | 9 | 21 | Contact information | 41 |
| 7.1.4 | Software Reset I ² C-bus address | 9 | 22 | Contents | 42 |
| 7.2 | Control register | 9 | | | |
| 7.3 | Register definitions | 11 | | | |
| 7.3.1 | Mode register 1, MODE1 | 12 | | | |
| 7.3.2 | Mode register 2, MODE2 | 12 | | | |
| 7.3.3 | PWM registers 0 to 3, PWMx—Individual brightness control registers | 13 | | | |
| 7.3.4 | Group duty cycle control, GRPPWM | 13 | | | |
| 7.3.5 | Group frequency, GRPFREQ | 14 | | | |
| 7.3.6 | LED driver output state, LEDOUT | 14 | | | |
| 7.3.7 | I ² C-bus subaddress 1 to 3, SUBADRx | 15 | | | |
| 7.3.8 | LED All Call I ² C-bus address, ALLCALLADR | 15 | | | |
| 7.4 | Active LOW output enable input | 16 | | | |
| 7.5 | Power-on reset | 16 | | | |
| 7.6 | Software Reset | 17 | | | |
| 7.7 | Using the PCA9633 with and without external drivers | 18 | | | |
| 7.8 | Individual brightness control with group dimming/blinking | 20 | | | |
| 8 | Characteristics of the I²C-bus | 21 | | | |
| 8.1 | Bit transfer | 21 | | | |
| 8.1.1 | START and STOP conditions | 21 | | | |
| 8.2 | System configuration | 21 | | | |
| 8.3 | Acknowledge | 22 | | | |
| 9 | Bus transactions | 23 | | | |
| 10 | Application design-in information | 26 | | | |
| 11 | Limiting values | 26 | | | |
| 12 | Static characteristics | 27 | | | |
| 13 | Dynamic characteristics | 28 | | | |
| 14 | Test information | 30 | | | |
| 15 | Package outline | 31 | | | |
| 16 | Handling information | 37 | | | |

Please be aware that important notices concerning this document and the product(s) described herein, have been included in section 'Legal information'.



© NXP B.V. 2006.

All rights reserved.

For more information, please visit: <http://www.nxp.com>
For sales office addresses, please send an email to: salesaddresses@nxp.com

Date of release: 20 December 2006
Document identifier: PCA9633_3