



## Features

- ✧ For surface mounted application
- ✧ Low forward voltage drop
- ✧ High current capability
- ✧ High reliability
- ✧ High surge current capability

## Mechanical Data

- ✧ Cases: D<sup>2</sup>PAK molded plastic
- ✧ Epoxy: UL 94V-0 rate flame retardant
- ✧ Terminals: Pure tin plated, lead free. solderable per MIL-STD-202, Method 208 guaranteed
- ✧ Polarity: As marked
- ✧ High temperature soldering guaranteed: 260°C/10 seconds at terminals
- ✧ Weight: 1.70 grams

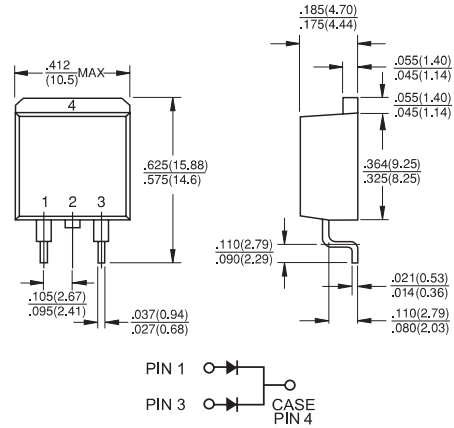

Dimensions in inches and (millimeters)

## Maximum Ratings and Electrical Characteristics

Rating at 25 °C ambient temperature unless otherwise specified.

Single phase, half wave, 60 Hz, resistive or inductive load.

For capacitive load, derate current by 20%

Type Number	Symbol	SRS 1620	SRS 1630	SRS 1640	SRS 1650	SRS 1660	SRS 1690	SRS 16100	SRS 16150	Units
Maximum Recurrent Peak Reverse Voltage	$V_{RRM}$	20	30	40	50	60	90	100	150	V
Maximum RMS Voltage	$V_{RMS}$	14	21	28	35	42	63	70	105	V
Maximum DC Blocking Voltage	$V_{DC}$	20	30	40	50	60	90	10	150	V
Maximum Average Forward Rectified Current See Fig. 1	$I_{(AV)}$	16								A
Peak Forward Surge Current, 8.3 ms Single Half Sine-wave Superimposed on Rated Load (JEDEC method )	$I_{FSM}$	150								A
Maximum Instantaneous Forward Voltage @8.0A	$V_F$	0.55		0.70		0.90		1.00		V
Maximum D.C. Reverse Current @ $T_c=25^\circ\text{C}$ at Rated DC Blocking Voltage @ $T_c=100^\circ\text{C}$	$I_R$	0.5				0.1				mA
		15		10		5.0		mA		
Typical Junction Capacitance (Note 2)	$C_j$	700		460		320			pF	
Typical Thermal Resistance (Note 1)	$R_{\theta JC}$	2.0								°C/W
Operating Junction Temperature Range	$T_J$	-65 to +125				-65 to +150				°C
Storage Temperature Range	$T_{STG}$	-65 to +150								°C

- Notes:
1. Thermal Resistance from Junction to Case Per Leg
  2. Measured at 1MHz and Applied Reverse Voltage of 4.0V D.C.

## RATINGS AND CHARACTERISTIC CURVES (SRS1620 THRU SRS16150)

FIG.1- MAXIMUM FORWARD CURRENT DERATING CURVE

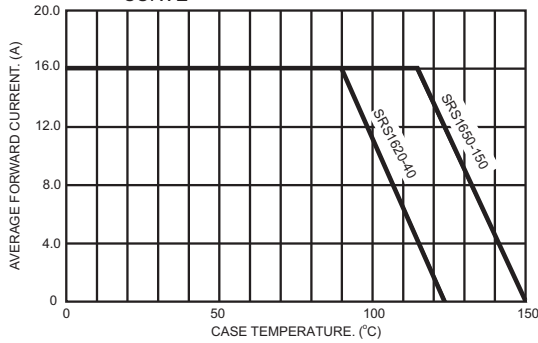

FIG.2- MAXIMUM NON-REPETITIVE FORWARD SURGE CURRENT PER LEG

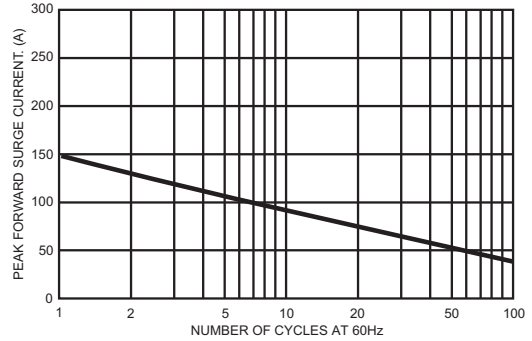

FIG.3- TYPICAL FORWARD CHARACTERISTICS PER LEG

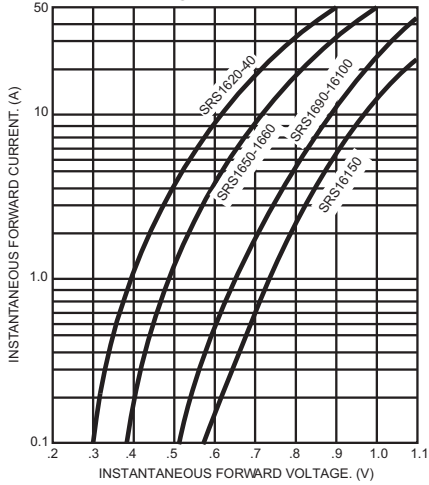

FIG.4- TYPICAL REVERSE CHARACTERISTICS PER LEG

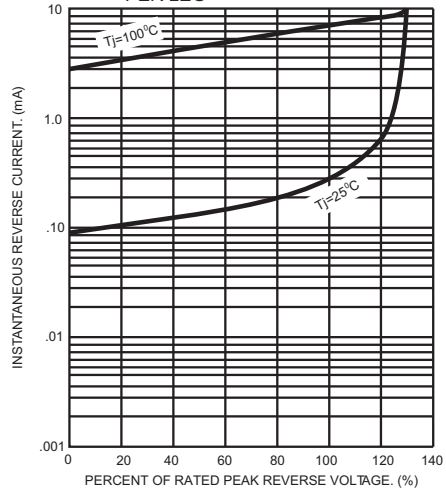

FIG.5- TYPICAL JUNCTION CAPACITANCE PER LEG

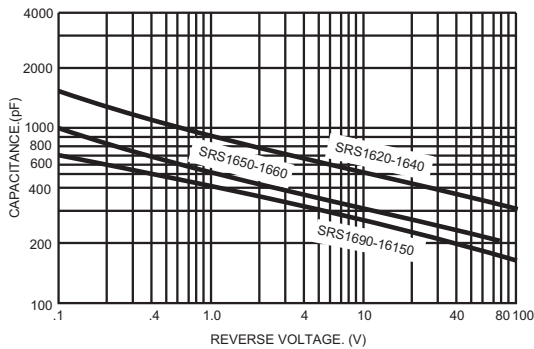

FIG.6- TYPICAL TRANSIENT THERMAL CHARACTERISTICS

