

Draft Data Sheet
INTEGRATED CIRCUIT
2004 Jul 26

OM1682 OM1682A

Precision triac control thermostat

INTEGRATED ELECTRONIC SOLUTIONS
1 BUTLER DRIVE
HENDON SA 5014
AUSTRALIA



Precision triac control thermostat**OM1682 OM1682A****CONTENTS**

1	FEATURES	12.2.2	Repairing soldered joints
2	GENERAL DESCRIPTION	12.3	SO
3	PINNING INFORMATION	12.3.1	Reflow soldering
3.1	Pinning layout	12.3.2	Wave soldering
3.2	Pin description	12.3.3	Repairing soldered joints
4	ORDERING INFORMATION	13	DEFINITIONS
5	BLOCK DIAGRAM	14	IES INFORMATION
6	FUNCTIONAL DESCRIPTION	15	DISCLAIMER ⁽¹⁾
6.1	OM1682 and OM1682A		
6.2	V _{CC} - Common, positive DC supply		
6.3	VEE - Negative DC supply, substrate		
6.4	TS and LS - Synchronisation from triac and line		
6.5	PWR - Power supply boost		
6.6	TRG - Triac gate drive		
6.7	SA and SB - Sensor inputs		
6.8	CAP - Timing capacitor		
6.9	RES and MOD - Select Resistive or Reactive load firing		
6.9.1	Resistive loads		
6.9.2	Reactive loads		
6.10	OM1682A Pins		
6.10.1	SW Control function switch		
6.10.2	LOT Logical output		
6.10.3	LIN Logical input		
7	IMPORTANT: ELECTRICAL SAFETY WARNING		
8	LIMITING VALUES		
9	CHARACTERISTICS		
10	APPLICATION INFORMATION		
10.1	Design considerations		
10.2	Circuit configurations		
10.3	Power supply requirements		
10.4	Gate drive		
10.5	Operating mode at switch on		
10.6	Zero-crossing detection		
10.7	Reactive loads		
10.8	Sensor circuits		
10.9	Common connection to load, triac, and sensor		
10.10	Using the Logical output and input controls in the OM1682A		
10.11	Application circuits		
11	PACKAGE OUTLINES		
12	SOLDERING		
12.1	Introduction		
12.2	DIP		
12.2.1	Soldering by dipping or by wave		

(1) The contents of this document are subject to the disclaimer on page 24

Precision triac control thermostat

OM1682 OM1682A

1 FEATURES

- Low external component count
- Variable ON and OFF cycle times
- With a resistive load, ON and OFF cycles always consist of an integral number of full mains cycles
- With an reactive load the ON period always has an odd number of half cycles, and the OFF period an even number (vice versa with the MOD option)
- No DC component in the AC supply current
- On chip circuit protection against triac gate spikes
- Low supply current
- Supply boost capability
- Sensor AC powered, thus minimising DC supply and filtering needs
- Hysteresis available from external circuit elements
- Negative triac gate drive (avoids insensitive quadrant operation)

2 GENERAL DESCRIPTION

The OM1682 (and OM1682A bonding variant) is a monolithic bipolar circuit for triggering a triac in applications where accurate control is required from a sensor such as an NTC (Negative Temperature Coefficient) or PTC thermistor. It is suitable for a broad range of applications, extending from the zero-crossing control of a heating element, to the control of fan motors or other complex loads. The OM1682A has additional logic control access, allowing monitoring of the input, and external control of the triac drive.

It is designed to accept a wide variety of resistive and other sensors, using a balanced current comparator input circuit in which a signal current derived from the sensor is compared with the current derived from a resistor.

The triac firing circuit is arranged to zero-crossing fire a resistive load; or by the use of option connections, can control reactive loads. It gives a controller circuit using a minimum number of components, yet allows considerable flexibility in the application configuration.

3 PINNING INFORMATION

3.1 Pinning layout

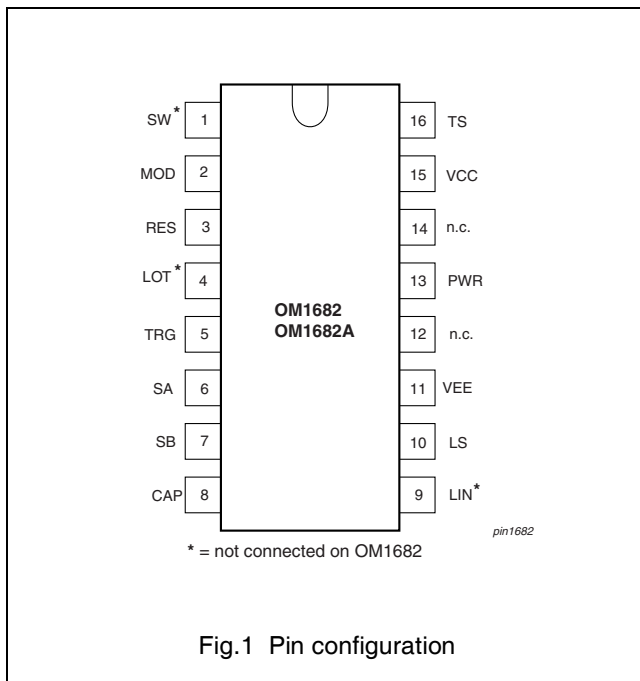

3.2 Pin description

SYMBOL	PIN	DESCRIPTION
SW	1 *	Switch to enable external logic
MOD	2	Mode select
RES	3	Res/Ind load select
LOT	4 *	Logical output
TRG	5	Triac gate drive
SA	6	Sense Input A
SB	7	Sense Input B
CAP	8	Timing capacitor
LIN	9 *	Logical input
LS	10	Line sensing
VEE	11	Negative supply
n.c.	12	not connected
PWR	13	Supply boost
n.c.	14	not connected
VCC	15	Positive Common
TS	16	Triac sense

* connected in the OM1682A only.

Precision triac control thermostat

OM1682 OM1682A

4 ORDERING INFORMATION

TYPE NUMBER	PACKAGE		
	NAME	DESCRIPTION	VERSION
OM1682P	DIP16	plastic dual in-line package; 16 leads (300 mil)	SOT38-1
OM1682T	SO16	plastic small outline package; 16 leads; body width 3.9 mm	SOT109-1
OM1682AP	DIP16	plastic dual in-line package; 16 leads (300 mil)	SOT38-1
OM1682AT	SO16	plastic small outline package; 16 leads; body width 3.9 mm	SOT109-1

5 BLOCK DIAGRAM

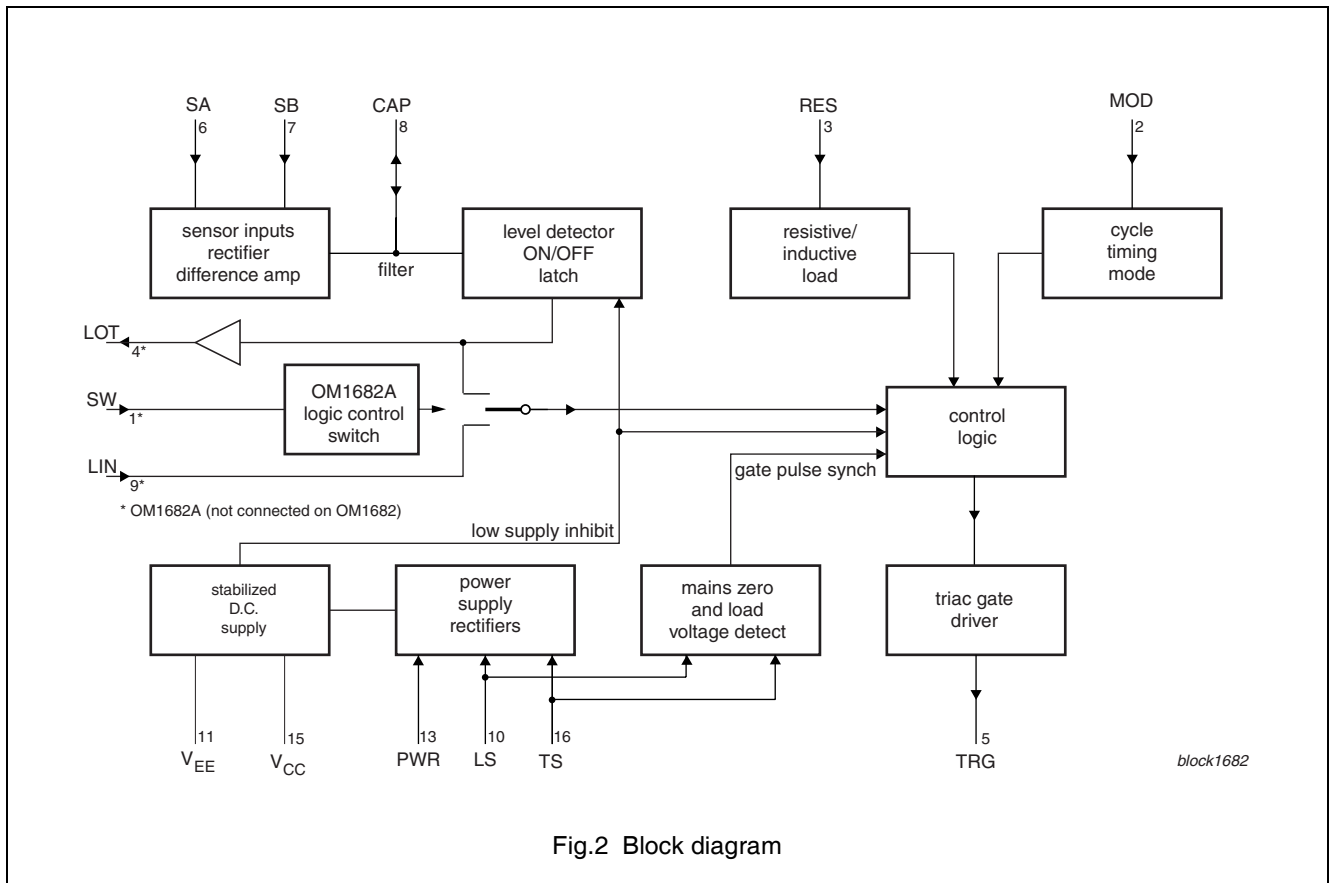

Fig.2 Block diagram

Precision triac control thermostat

OM1682 OM1682A

6 FUNCTIONAL DESCRIPTION

6.1 OM1682 and OM1682A

While the OM1682 and OM1682A use the same bipolar silicon crystal (die), they are bonded differently at packaging to offer greater flexibility in function. The OM1682 has 5 pins not bonded, and does not offer access to the ON/OFF output of the input bridge latch, and neither does it allow an external logic (ON/OFF) control of the triac drive. By providing access to 3 additional pins, the OM1682 A offers a signal indicating the condition of the input circuit latch as well as a control facility that permits external switching of the triac drive output. The addition 3 pins are SW, LOT and LIN.

6.2 V_{CC} - Common, positive DC supply

The positive DC supply rail for the control IC type OM1682 is used as

the common reference. This is always connected to the T1 terminal of the triac, and being the positive supply rail allows negative gate drive to the triac in both positive and negative supply half cycles on T2. By driving the triac in this way the insensitive quadrant (negative T2 voltage, and positive gate triggering signal) of triacs is avoided.

6.3 V_{EE} - Negative DC supply, substrate

This pin connects to the internally generated and regulated negative DC supply, and should be bypassed to V_{CC} (common) by a capacitor of typically 100 µF. The capacitor needs to be sufficiently large to maintain the operating voltage during the half cycle when it is not being charged, and to provide the energy to drive the triac gate during the gate pulse.

Internal supply sensing prevents the commencement of an ON cycle while the voltage is too low for reliable circuit operation. If during an ON cycle the supply voltage falls below this level the ON cycle will terminate at the first opportunity consistent with the cycle algorithm for the selected mode.

6.4 TS and LS - Synchronisation from triac and line

Two synchronisation inputs provide both the power supply and signals indicating the phase and magnitude of the AC signal on terminal T2 of the Triac (TS) and the load or AC supply (LS). Three states, positive, zero and negative, of each of these signals are recognised for synchronisation of the triggering times to the mains.

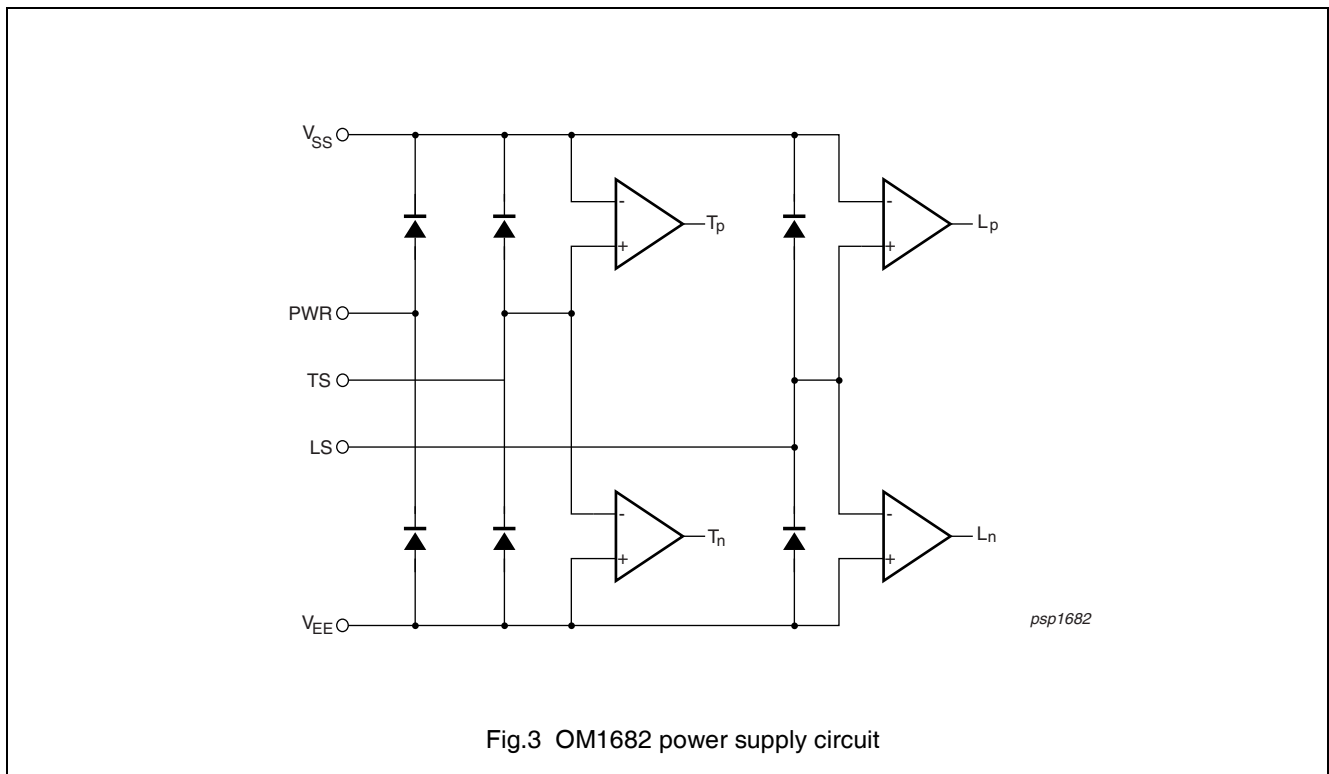

Fig.3 OM1682 power supply circuit

Precision triac control thermostat

OM1682 OM1682A

See Figure 3, OM1682 Power Supply Circuit. A resistor network taken between terminal T2 of the Triac (TS) or the load or AC supply (LS) and VEE provides the zero-crossing signals. As the AC signal passes through zero, comparators provide control signals T_p (when $V_{TS} > VCC$) and T_n (when $V_{TS} < VEE$) indicating whether the voltage on TS or LS is greater or less than VCC or VEE respectively. A resistor network ensures that these switching points correspond to equal positive or negative thresholds about the AC zero thus giving a symmetrical zero-crossing drive to the triac gate.

For a resistive load the zero-crossing information for the triac gate drive is obtained from pin LS. In circuits where the triac and the control circuit are connected to one side of the AC supply, LS also provides power and zero-crossing information while the triac is off, and no connection is needed to TS. However for reactive loads it provides the gate control signals during the ON period.

Synchronisation is obtained from the threshold comparators at the levels of VCC and VEE on the chip. Adjustment of the switching point, and hence the firing pulse width and symmetry about the zero crossing point is possible by varying the values of the resistors connected between TS and the triac T2, the resistor to VEE, and the resistor to VCC; and LS to the load, VEE and VCC.

With a resistive load, when the triac has switched on and an AC signal is no longer available on T2 of the triac, the synchronisation information, and the power supply are derived via pin LS from either the load, or from the AC supply (depending on the circuit configuration used). The series resistor to the load (or AC supply), together with resistors from pin LS to VEE and to VCC, are chosen to be suitable values to generate the triac

gate pulse about the zero-crossing point to ensure reliable firing of the triac.

In the circuit configuration in which the signal for LS is derived from across the load, there will be no AC signal until the triac has fired. Therefore, while the triac is OFF, synchronising information and the DC power supply is derived from the AC signal that is then present across the triac via pin TS.

6.5 PWR - Power supply boost

An AC signal applied to this terminal provides additional DC power supply current using on-chip rectifiers. This is usually provided via an additional resistor connected from the PWR pin to the AC supply. See Figure 3, OM1682 Power Supply Circuit.

If the OM1682 is able to operate with narrow gate drive pulses, and only requires a small average DC supply current, then there may be sufficient power available from the synchronising drive resistors to LS and TS. However large magnitude triac trigger pulses or extended pulse widths to reach triac latching current levels with light loads may require additional power sourcing via this terminal. This will be especially so with reactive loads, with resistive loads drawing low currents (less than 400 VA), or with triacs specified for low gate trigger current sensitivity. No synchronising signals are derived from the PWR terminal.

6.6 TRG - Triac gate drive

The triac gate output drives the gate through a current setting resistor. It has in-built protection to withstand transient voltage signals which may be induced on the gate of the triac by mains transients during firing. The gate drive current should be set to a value suited to the gate sensitivity of the triac used. The firing pulse width will need to be of such a width that the

specified latching current of the triac when used with the design load has been reached before the gate pulse ends. The average current this requires may preclude the powering of the circuit during the ON cycle from the LS pin supply alone (to achieve the required gate pulse width), and an additional DC boost may be needed from the PWR terminal.

With a resistive load the triac is fired at all times with a signal applied to the gate during the zero-crossing of the mains. However, with a reactive load the current is no longer in phase with the supply voltage across the load; and there is no signal available to indicate that the current is approaching zero at the end of each conducting half-cycle. When the current falls below the triac holding current, the triac switches off, and the supply voltage at that time appears across the triac. When configured to fire reactive loads, the OM1682 detects the presence of this voltage by the signal on pin TS when the triac turns off, and acts to re-apply the gate signal until the signal on TS falls, indicating that the triac has fired. The gate drive is held on for short delay time after the voltage on T2 fails to ensure the triac current has reached its latching point.

With an reactive load there is a transient voltage present on the triac T2 during the conduction period, and radio frequency interference (RFI) suppression and suitable snubbing measures may be needed.

Precision triac control thermostat

OM1682 OM1682A

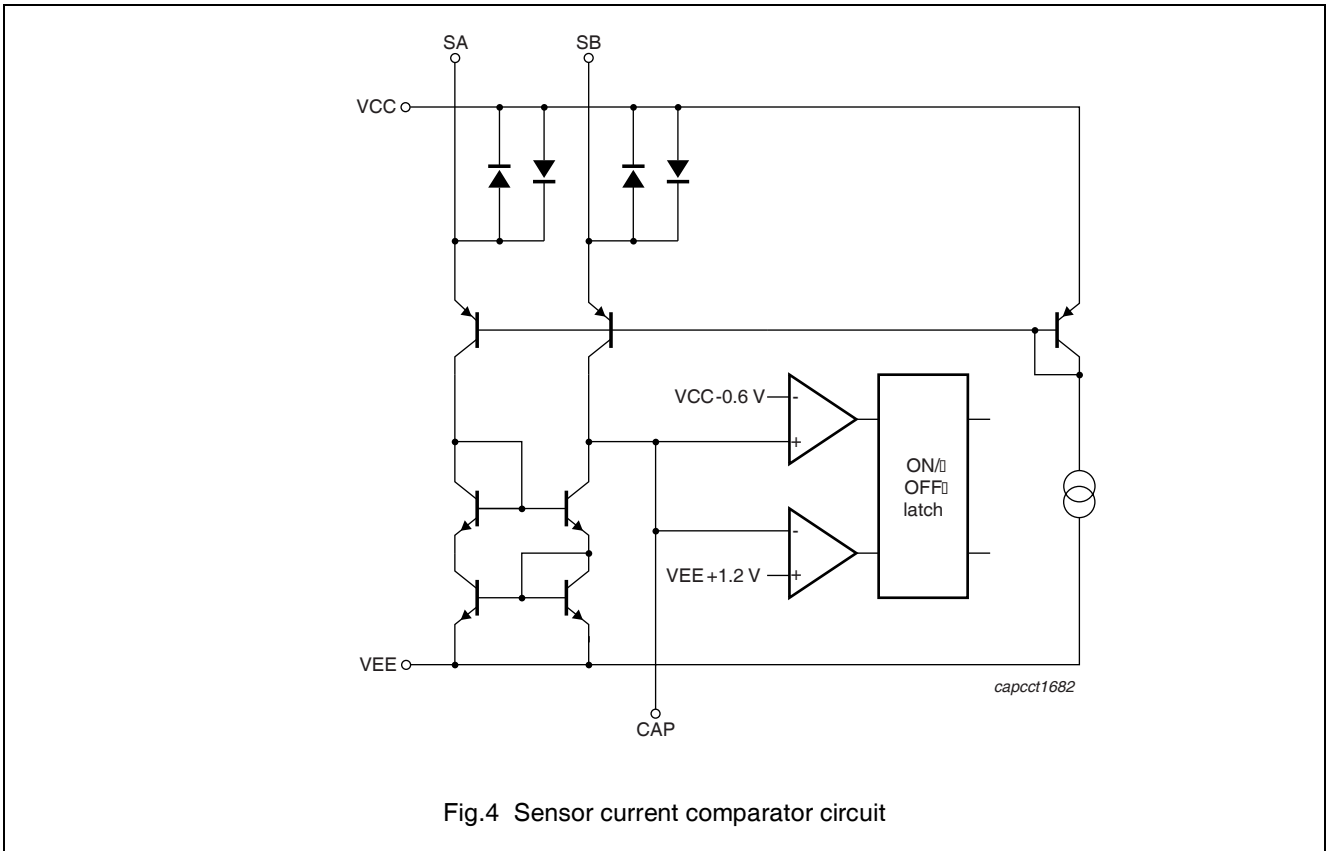

Fig.4 Sensor current comparator circuit

6.7 SA and SB - Sensor inputs

The sensor inputs are symmetrical current inputs designed to accept AC signals referenced to common. See figure 4, Sensor current comparator circuit

By not using the DC supply rail to drive the sensing inputs, problems associated with providing sufficient DC current to drive the sensor and associated networks over the full operating range are avoided. In addition by providing balanced differential inputs operating at close to the VCC rail potential, control signals which either increase or decrease with the parameter to be regulated (temperature, pressure, humidity etc.) can be handled.

A sensitive sensor can be used together with a level setting variable

resistor in a bridge arrangement. A resistor can apply a current proportional to the voltage across the AC sensor to one of the two sensing inputs, and another equal resistor will give a current derived from the voltage on the setting resistor to the other. The circuit will be balanced when the two input currents are equal, and any change in the sensor resistance will generate a difference signal between the input currents to SA and SB. This difference is integrated in a capacitor connected to pin CAP.

When the current into pin SA is greater than the current into pin SB, the voltage on pin CAP will be driven negative towards the OFF threshold comparator. When the current difference is reversed, and the current into SB is the greater, then

the current difference will charge CAP positively towards the upper ON threshold.

A typical circuit will power this sensing circuit via a high value resistor taken from the AC supply. While the circuit is in balance the timing capacitor voltage remains steady, but once the sensed parameter changes and causes an imbalance, then the capacitor will charge or discharge depending on which input current is the greater as a result of the imbalance, and after a delay reach the threshold voltage and initiate a change from ON to OFF or vice-versa.

The charging or discharging current is the difference between the two current input signals applied to SA and SB.

Precision triac control thermostat

OM1682 OM1682A

An imbalance (apart from that resulting from the action of the sensor) between the currents applied to SA and SB can be created by an additional resistive path that introduces an AC signal from the AC signal across the triac when it is off to add to the signal already present in SA or SB. This imbalance can be used to increase the hysteresis around the control point, or to decrease it and to force more frequent cycling between the ON and OFF cycles. In the application circuit where the sensor is powered from across the triac (OFF period) or from across the load (ON) then suitable selection of fixed resistor values give this electronically induced imbalance.

The timing capacitor connected to the CAP terminal provides inherent filtering of the sensing signal, and as the SA and SB inputs are driven by AC signals, filtering of transient interference signals is inherent in this circuit. However they may also be driven from a positive DC source- possibly from a remote sensor with its own power supply, and still have the advantage of the inherent interference rejecting characteristics of the timing capacitor.

Only the positive half of the input cycle is used to generate the difference between SA and SB: on the negative half cycle the voltage is clamped to one VBE below the VCC rail.

6.8 CAP - Timing capacitor

The timing capacitor is connected from CAP to either VEE (substrate, -ve) or VCC (common, +ve). The charging and discharge times of this capacitor set the ON and OFF cycle times and give minimum times proportional to the capacitance values as well as to the maximum difference in current levels at which the two sensor inputs are driven.

The charging and discharging periods, that is the ON or OFF times, vary with the magnitude of the difference in input currents applied to SA and SB from the sensor. When the capacitor charges towards the VCC rail, and reaches an upper threshold of one VBE below the VCC rail, then the request for firing latch is set in the ON condition; the control circuit is ready to start an ON cycle at the next appropriate zero-crossing of the mains supply. See figure 4, Sensor Current Comparator Circuit.

The ON period is synchronised with the mains zero crossing signals so that with a resistive load an integral number of full cycles makes up the ON period, and no DC signal is generated in the supply line. With an reactive load the OM1682 uses either an odd number of half cycles during the ON period, with an even number in the OFF period, or vice-versa. This ensures that for an reactive load every ON period starts by conducting in the opposite direction to the first half cycle of the previous ON period.

During the ON cycle, the imbalance in the input signal currents that caused the capacitor to charge to the upper threshold voltage, will change, and the new difference between the signals into SA and SB discharges the capacitor, with the voltage on the CAP pin approaching the VEE rail. The lower threshold is two VBE above VEE, and when this threshold is reached the latch which was set by the request for an ON cycle is reset. When the ON latch is reset, the timing circuit stops driving the gate only after the programmed even or odd number of conducting half cycles.

PIN CONNECTION		TYPE OF LOAD	OPERATING MODE
RES	MOD		
high (true)	high (true)	resistive	Start on triac zero crossing, run on load signal zero crossing
high (true)	low (false)	resistive	Start and run on supply signal zero crossing
low (false)	high (true)	leading	Odd number of ON half cycles, even number of OFF cycles
low (false)	low (false)	leading	Even number of ON half cycles, odd number of OFF half cycles
low (false)	high (true)	lagging	Even number of ON half cycles, odd number of OFF half cycles
low (false)	low (false)	lagging	Odd number of ON half cycles, even number of OFF cycles

6.9 RES and MOD - Select Resistive or Reactive load firing

The OM1682 provides for four different modes of operation; two for use with resistive loads and two for

use with reactive loads. These modes are selected by pins RES and MOD. These pins are logically true when left open (high) and false when shorted to VEE (low). RES false (low) selects the reactive modes.

6.9.1 RESISTIVE LOADS

With RES true (high) all triggering occurs at zero crossings as sensed by TS or LS, and both ON and OFF periods have a duration of an integral number of AC supply cycles. With a

Precision triac control thermostat

OM1682 OM1682A

suitable choice of component values triggering pulses during the ON period begin before the true zero is reached so that the ON state of the triac is maintained as the current falls below the holding current level and continues into the new half cycle until the triac latching current is reached.

With MOD false the circuit operates in a conventional zero crossing mode with crossings sensed via LS; see Fig.5. The sense line TS is unused and may be left open. In this mode it is necessary that T1 of the triac and V_{CC} of the circuit are connected to one line of the AC supply.

The second resistive mode with MOD true (Fig.7) is provided for applications in which it is convenient to have a common connection between one terminal of the sensor element and one terminal of the load. This is achieved by referencing the control circuit to the junction of the triac and the load. Now there is no single synchronising signal available both while the triac is ON and while it is OFF, It is therefore necessary to sense the voltage across the triac via a resistive network to TS while the triac is OFF, and to sense the voltage across the load via a resistive network to LS while the triac is ON.

6.9.2 REACTIVE LOADS

With RES false (low) the circuit is configured for use with reactive load (Fig.6). With reactive loads it is necessary that T1 of the triac and V_{CC} of the circuit are connected to one line of the AC supply. The initial trigger of an ON period occurs at a zero crossing sensed by LS. With lagging loads current will continue to flow through the load during the next AC supply zero crossing and fall below the triac holding current some time later. When this point is reached the voltage across the triac rises, is sensed via TS, and causes a re-triggering pulse for the triac which

is maintained until the voltage sensed by TS falls. A small trigger turn off delay is implemented so that the triac current has time to reach the latching level. The circuit logic ensures that the first half cycle of each ON period is of opposite phase to that of the first half cycle of the previous ON period.

The state of the MOD pin influences the end point of a firing burst. With MOD true the interval within which triggering pulses are generated terminates as the voltage sensed by LS enters the zero crossing region in the same direction as at the commencement of the burst. Thus the trigger pulses are generated during an even number of mains half cycles. If the load is slightly leading then the load current will cross zero slightly before the end of the interval and another half cycle of triac conduction will be generated and the triac is ON for an odd number of half cycles. With a slightly lagging load the zero crossing occurs just beyond the trigger pulse interval and another conduction half cycle is not produced. The total number of half cycles of conduction is then even.

With MOD false the burst interval terminates as the voltage sensed by LS enters the zero crossing region in the opposite direction as at the commencement of the burst. Thus with leading loads the burst will comprise an even number of conduction half cycles whereas lagging loads will have an odd number.

Conduction bursts of an even number of half cycles appear to result in a zero DC component averaged over a single ON periods but this is severely disturbed by the inequality of current waveforms in the first and subsequent half cycles. A zero average is still maintained over two consecutive ON periods. Careful waveform analysis shows that the magnitudes of low frequency waveform components are

the same for bursts of odd and even numbers of half cycles. But with bursts of an odd number of cycles the first half cycle of an ON period is in the opposite phase to the last half cycle of the previous ON state thus minimising problems of remanence with loads containing magnetic materials.

6.10 OM1682A Pins

There are 3 additional pins connected in the OM1682A to offer greater control and flexibility in application. These are as follows.

6.10.1 SW CONTROL FUNCTION SWITCH

If this pin is connected to VEE then the OM1682A options are enabled. If SW is open, then an internal path is established within the OM1682A that connects the output of the ON/OFF latch directly to the triac drive circuit.

6.10.2 LOT LOGICAL OUTPUT

The LOT logical output is an open collector transistor (emitter to VEE) capable of sinking 50 μ A when ON.

If SA is greater than SB then the ON/OFF latch is driven to the OFF state. In this condition with $I_{SA} > I_{SB}$ then the transistor will be on, pulling the LOT pin down to VEE.

LOT may be connect to LIN, and in this arrangement will function normally as the OM1682, except there is the possibility to hold the triac drive OFF by driving this connection with an external signal to also pull this common connection low. In this connection an external pull-up resistor is not required.

Alternatively, because the SA and SB input circuit is symmetrical, exchanging SA and SB will invert the function of LOT, providing a logic signal which can drive logic processing circuits external to the OM1682A.

Precision triac control thermostat

OM1682 OM1682A

The LOT signal is still present even when SW is open, although in this configuration the LOT signal drives the triac output circuit internally, and LIN is prevented from functioning.

For supply voltage magnitudes less than the internal supply inhibit threshold, but sufficient for internal circuit operation, LOT is forced low.

6.10.3 LIN LOGICAL INPUT

The LIN logical input provides access to the triac synchronization and

output drive circuit. While the triac drive is synchronous with mains current zero crossing, the LIN signal is not required to be synchronous, and its state is only used when the next appropriate opportunity occurs to start a sequence of triac conducting half cycles, or to conclude an operating burst. The state of the internal supply inhibit circuit is also taken into account.

If open circuit, LIN is pulled high above VEE to a level of $4 \times V_{BE}$

(about 2.5 V), above an input threshold of $2 \times V_{BE}$.

LIN can be driven by a standard CMOS output port, with a pull down input current of typically $3 \mu\text{A}$. If pulled up to VCC the input junctions are reverse biased and there is no input current.

7 IMPORTANT: ELECTRICAL SAFETY WARNING

OM1682 and OM1682A circuits are connected to the mains electrical supply and operates at voltages which need to be protected by proper enclosure and protective covering. Application circuits for OM1682 and OM1682A should be designed to conform to relevant standards (such as IEC 65, or Australian Standards AS3100, AS3250 and AS3300), it should only be used in a manner that ensures the appliance in which they are used complies with all relevant national safety and other Standards.

It is recommended that a printed circuit board using this integrated circuit be mounted with non-conductive clips, and positioned such that the minimum creepage distances from the assembly to accessible metal parts, and between high voltage points cannot be transgressed.

It should be noted that as there are Mains Voltages on the circuit board adequate labelling should be attached to warn service personnel, and others, that this danger exists.

A control board assembly should be mounted, preferably vertically, with sufficient free air flow across its surface to prevent the heat dissipated in various components from causing an unacceptable rise in the ambient temperature. The triac also needs to have an adequate heatsink, as exceeding its rated maximum junction temperature can result in loss of control, unpredictable behaviour, and possible dangerous conditions.

The board should be mounted in a place that is clean and dry at all times, not subject to condensation or the accumulation of dust and other contaminants.

Precision triac control thermostat

OM1682 OM1682A

8 LIMITING VALUES

In accordance with the Absolute Maximum Rating System (IEC 134).

SYMBOL	PARAMETER	CONDITIONS	MIN.	MAX.	UNIT
I	DC current (any pin except 5 and 11)		–	20	mA
I	DC current (pins 5 and 11)		–	70	mA
V _{CAP}	Voltage range CAP, pin 8	V ₈₋₁₅	V _{11-0.8}	+0.8	V
V _{SA}	Voltage range SA, pin 6	V ₆₋₁₅	-0.8	+0.8	V
V _{SB}	Voltage range SB, pin 7	V ₇₋₁₅	-0.8	+0.8	V
V _{TRG}	Voltage range TRG, pin, transient	V ₅₋₁₅	V ₁₁₋₃₀	+50	V
V _{MOD}	Voltage range MOD, pin 2	V ₂₋₁₁	-0.8	+0.8	V
V _{RES}	Voltage range RES, pin 3	V ₃₋₁₅	-0.8	+0.8	V
V _{SW}	Voltage range SW, pin 1, see note 1	V ₁₋₁₅	-0.8	+0.8	V
V _{LOT}	Voltage range LOT, pin 4, see note 1	V ₄₋₁₅	V _{11-0.8}	+0.8	V
V _{LIN}	Voltage range LIN, pin 9, see note 1	V ₉₋₁₅	V _{11-0.8}	+0.8	V
P _{tot}	total power dissipation	–	–	300	mW
T _{stg}	storage temperature		-40	+150	°C
T _{amb}	operating ambient temperature		0	+125	°C

Note

- Pins 1, 4 and 9 (SW, LOT, and LIN) are only connected in the OM1682 A. These pins are not bonded in the OM1682.

9 CHARACTERISTICSAt T_{amb} = 25°C; Voltages are specified with respect to V_{CC}.

SYMBOL	PARAMETER	CONDITIONS	MIN	TYP	MAX	UNIT
Power supply						
-VEE	dc supply voltage clamp	regulated dc supply voltage	6.0	6.5	7.0	V
-IEE	quiescent current	with pins SA, SB and TRG open circuit	–	–	200	µA
-V _{inh}	internal supply inhibit voltage	voltage less than VEE clamp voltage	–	-VEE+1	–	V
Gate drive						
I _G	gate current (triac T1 to V _{CC})	set by R _G connected from TRG to gate	–	–	50	mA
t _{W(g)}	gate pulse width	reactive mode	130	160	250	µs
Power sensing inputs LS and TS						
V _{UT}	upper threshold		–	0	–	mV
-V _{LT}	lower threshold		–	VEE	–	V
Measuring inputs SA and SB						
V _S	Voltage	I _{SA} = I _{SB} = +50 µA	–	0	–	mV
V _{OS}	Offset voltage, V _{SA} - V _{SB}	I _{SA} = I _{SB} = +100 µA	-5	–	+5	mV
I _{S(peak)}	Peak sense input current	I _S = I _{SA} + I _{SB}	–	–	500	µA

Precision triac control thermostat

OM1682 OM1682A

SYMBOL	PARAMETER	CONDITIONS	MIN	TYP	MAX	UNIT
$I_{CAPoffset}$	Offset current (as a % of I_{SA} or I_{SB} , where $I_{CAPoffset} = (I_{CAP}/I_{SA}) \times 100\%$, measured at $I_{SA} = I_{SB} = +100 \mu A$ dc)		-2.2	0	+2.2	%
Timing capacitor						
$I_{CAP}/(I_{SA}-I_{SB})$	Charge current ratio	$I_{SA} = I_{SB} = +100 \mu A$	-	0.9	-	
OM1682A control functions						
$I_{LOT(low)}$	logical output pull down current	$V_{LOT} = VEE + 0.5 V$	50	-	-	μA
$I_{LOT(high)}$	logical output high leakage	$V_{LOT} = VCC$	-	-	1	μA
$I_{LIN(low)}$	logical input current (low)	$V_{LIN} = VEE$	-	3	-	μA
$I_{LIN(high)}$	logical input current (high)	$V_{LIN} = VCC$	-	-	1	μA
$V_{LIN(threshold)}$	logical input voltage threshold	with respect to VEE	0.8	1.2	1.6	V

10 APPLICATION INFORMATION

10.1 Design considerations

Resistors connected directly to the AC supply rail should be specified to withstand the voltage. It is recommended that Philips Components VR37 (or VR25) high-ohmic / high-voltage resistors be used. These resistors meet the safety requirements of a number of international standards on high voltage applications.

These circuits are designed to demonstrate the flexibility of applications using the OM1682 and OM1682A. No attempt has been made to use the minimum number of components, although there are opportunities to reduce the component count by using resistors for multiple functions. There can be some interaction with reduced accuracy, and a good understanding of the OM1682 and OM1682A is required to find the most cost efficient design.

10.2 Circuit configurations

Triac control circuits usually have the load connected between the mains supply and T2 of the triac, and the controller together with triac terminal T1 are connected to the other side of the supply. This is the application

circuit in figure 5, OM1682 Application Diagram: Resistive Heating Load, referenced to mains. An alternative circuit in which the T2 of the triac and the load are both connected to the supply, is shown in figure 7; here the controller, and temperature sensor are connected to the junction of the load and triac terminal T1. Other circuit configurations will depend on whether the load is resistive, and zero-crossing fired, or is reactive and must be fired as soon as possible after the current has fallen to zero and the triac has switched off (for example figure 6).

10.3 Power supply requirements

The DC power supply current available for the operation of the circuit is derived from the resistors connected to the TS and LS terminals, plus boost power if needed from PWR. On the negative half cycle of the AC signals applied to these resistors, the current into the OM1682 charges the 100 μF power supply capacitor connected between VCC and VEE.

Apart from the current required by the chip, the triac gate drive presents the major DC current requirement of the circuit. As the gate pulse must be wide enough for the load current to reach the triac's specified holding

current, this may be a significant load on the DC supply (especially with small resistive and reactive triac loads). Hence the provision of the PWR terminal which may be needed for circuits requiring wider gate drive pulses.

For moderate supply requirements without separate power boost it is recommended that PWR be connected to LS.

10.4 Gate drive

The 300 Ω gate resistor shown in the application circuits gives a little over 10 mA gate drive. Thus for the circuit shown a triac would need to be specified that is suitable for 10 mA triggering with negative triggering signal for both positive and negative voltage on T2. From the threshold levels determined from the resistive networks on LS and TS and the AC supply, the gate pulse width can be calculated (assuming a sine wave supply). The specification of the triac will indicate the latching current for switch-on, and knowing the minimum load with which the circuit is to operate, then proper design will ensure that the gate pulse is not removed before the triac current reaches this figure.

Precision triac control thermostat

OM1682 OM1682A

10.5 Operating mode at switch on

The return connection of the capacitor connected to the CAP terminal may determine whether the OM1682 is in an ON or an OFF cycle once the power supply reaches its operating voltage after the supply voltage is applied.

The application circuits show the capacitor connected to VEE, so that it will initially be in the OFF mode at switch on. With connection of the capacitor between the CAP pin and VCC, at mains switch ON the CAP will be in the ON mode. If the power supply voltage rises more slowly than the capacitor on pin CAP, then when the circuit starts operation, the voltage on CAP may have already reached a level sufficient to change the state of the ON/OFF latch.

10.6 Zero-crossing detection

The two thresholds at which the zero-crossing of the input voltages on LS and TS are sensed are the two supply rails, VCC and VEE. This means that a network of resistors is required to ensure switching at the same threshold above the VCC common positive rail as below it. In the circuits shown in Fig.5, Fig.6 and Fig.7, two 220 k Ω resistors are used. One is connected between the AC supply and the input pin LS or TS, and the second from the pin to VEE (the negative DC supply rail of the chip). The positive threshold is therefore an equal voltage above VCC due to the divider action of the resistors, while the negative threshold is still equal to VEE as at this point no current is flowing in the second resistor.

If a third resistor is added to each network from the input pin LS or TS to VCC suitable values can be calculated to give equal positive and negative thresholds larger than the DC supply voltage of VCC – VEE. For example, if VCC – VEE = 7 V, and

the resistor to the supply is 220 k Ω from LS, then in Fig.5 where the resistor from LS to VEE is the same (220 k Ω), the upper threshold is +7 volts, and the lower one –7 volts. However if the resistor between LS and VEE is only 110 k Ω , and a further resistor of 220 k Ω is connected between LS and VCC, then the thresholds are \pm 14 volts.

Note that the current flowing in the second resistor causes a negligible loss to the DC supply, as the voltage across it is limited to approximately VCC – VEE.

10.7 Reactive loads

The circuit of Fig.6: OM1862 application diagram; refrigerator control, referenced to mains, shows the changes made from Fig.5 to use the OM1682 with a reactive load. The RES terminal is taken to VEE to set the reactive triggering option, and the synchronising signals are needed from across the triac to provide the feedback for the circuit to apply the triggering pulses to the triac.

10.8 Sensor circuits

In all of the circuits shown the sensor is common to the VCC and triac T1 terminals. Other circuits can use the sensor in series with one of the input pins SA and SB. In the same way, because the input circuit is symmetrical, sensors which generate signals varying in the opposite direction (for example positive temperature coefficient resistors) can be accommodated by exchanging the inputs. Lower impedance sensors may also be used with suitable modifications to the input circuit.

In Fig.5 and Fig.6 AC feedback can be taken from the triac T2 to the junction of the sensing resistor, or the variable resistor (for example via a 10 M Ω resistor), and in this way enhance, or reduce the hysteresis of the sensing circuit.

10.9 Common connection to load, triac, and sensor

See the circuit in Fig.7 OM1682 Application Diagram: Sensor and Control Circuit Common to both Load and Triac. This permits remote mounting of the sensor and a heater or other load with only three connections.

Because the AC sensor drive is taken from the AC signal across the triac while the triac is OFF, and from across the load while it is ON, this permits adding an out of balance AC signal into the sensing circuit to increase or decrease the effective hysteresis while the control circuit is cycling. In Fig.7 this is shown by the use of 470 k Ω resistors in the sensor bridge circuit except for one which is 420 k Ω , and thereby introduces 10% hysteresis by deliberately driving the input circuit further out of balance as soon as it switches.

10.10 Using the Logical output and input controls in the OM1682A

The Logical output and input facility connected on the OM1682A offers considerable flexibility in allowing easy interfacing with external control circuits.

Figure 9 shows a timing circuit with a press button start that runs for a fixed time before locking out until the button is pressed again. In addition to the run timer which can be set for a period between 1 and 4 hours, it has light emitting diode indication of mains presence, timer running, and power on the load.

In figure 10 the LOT signal trips a latch as soon as the thermostat input reaches a set temperature, turning the triac drive OFF. A start button will begin another cycle.

Precision triac control thermostat

OM1682 OM1682A

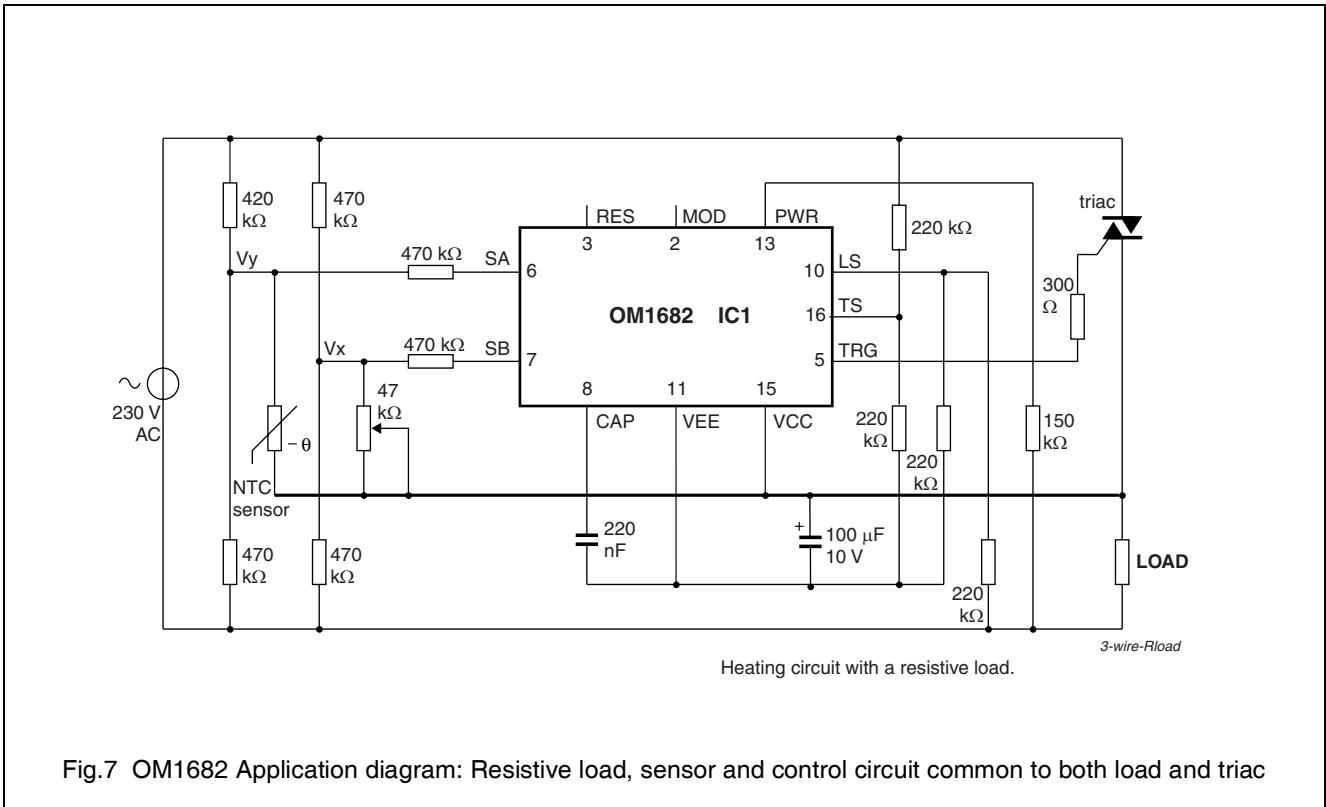

Fig.7 OM1682 Application diagram: Resistive load, sensor and control circuit common to both load and triac

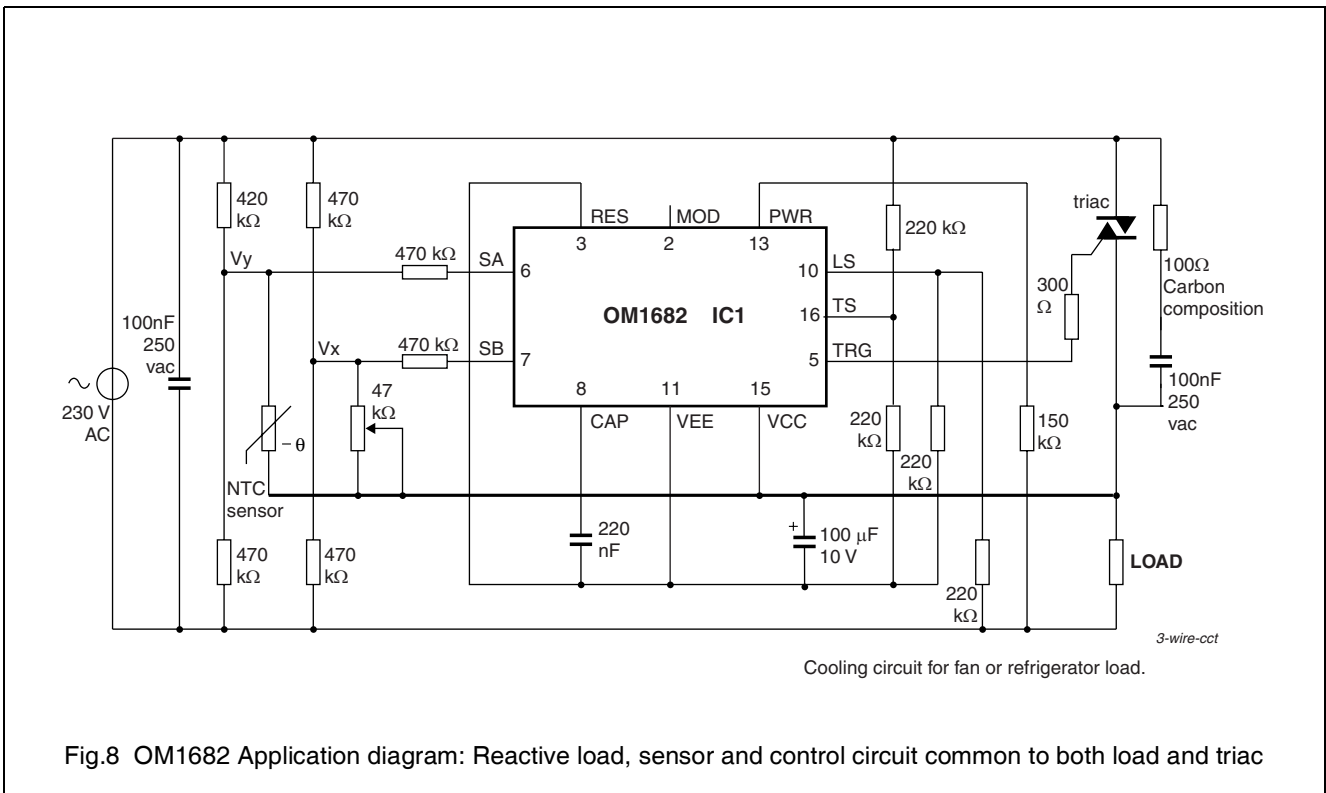

Fig.8 OM1682 Application diagram: Reactive load, sensor and control circuit common to both load and triac

Precision triac control thermostat

OM1682 OM1682A

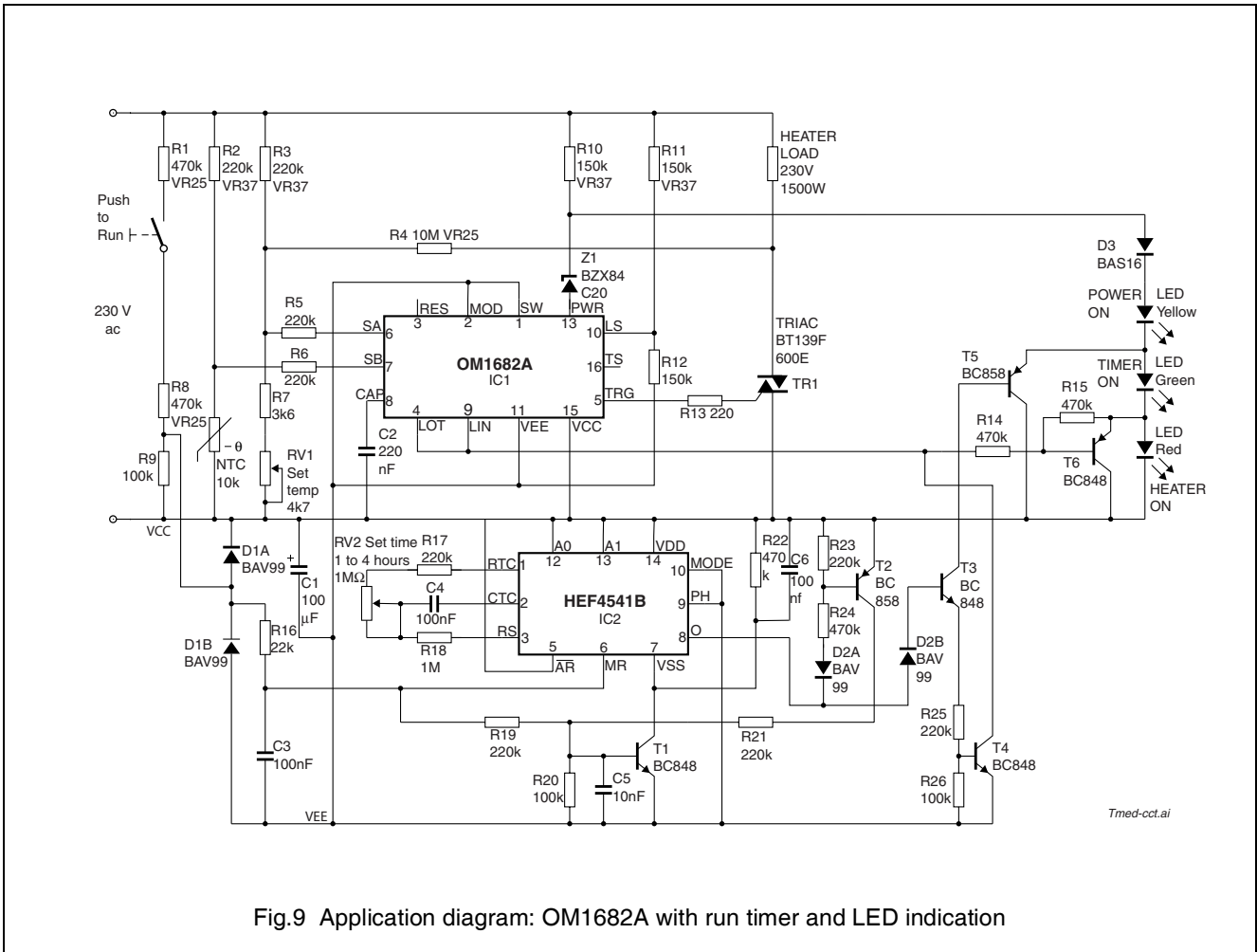
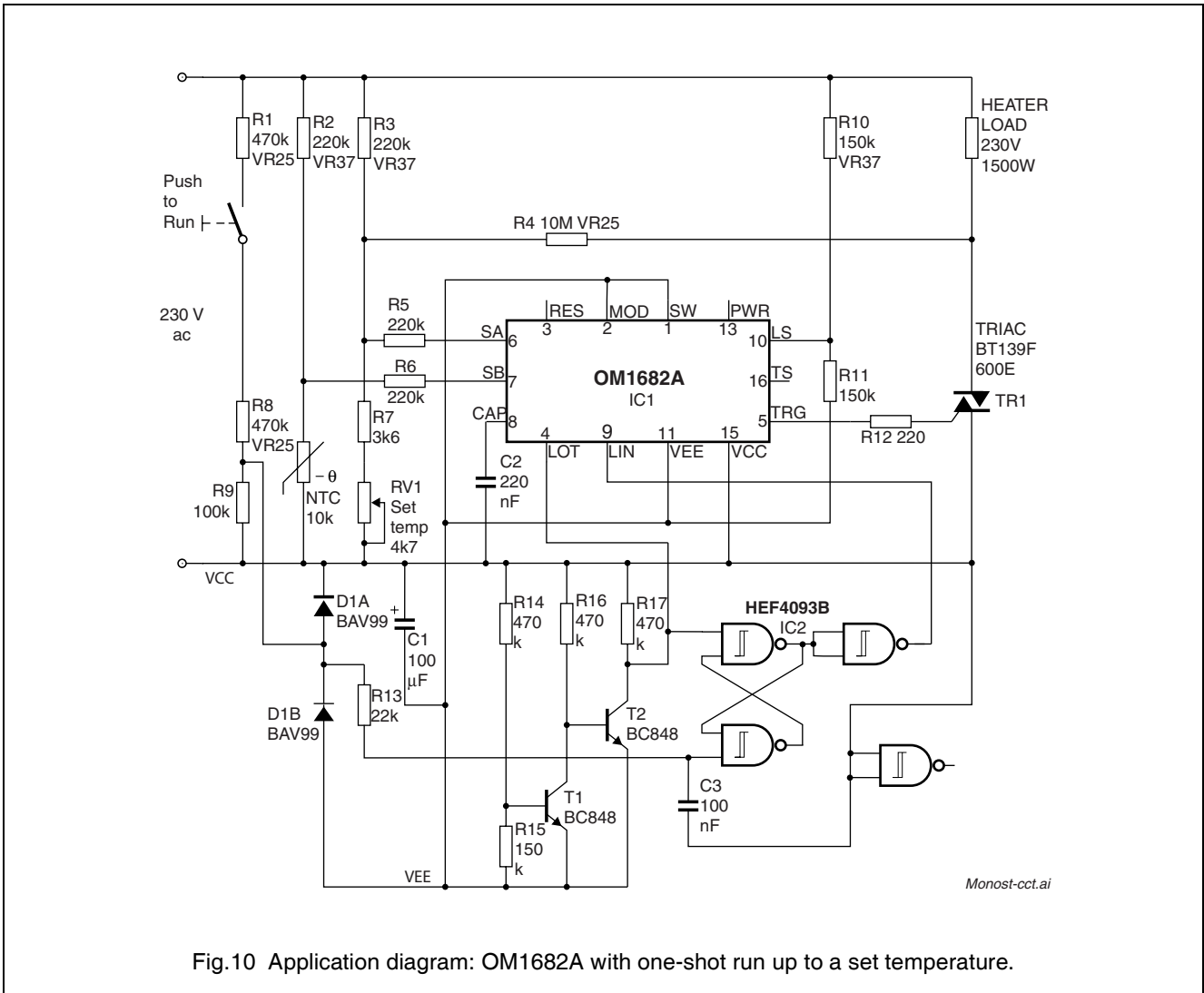

Fig.9 Application diagram: OM1682A with run timer and LED indication

Precision triac control thermostat

OM1682 OM1682A



Monost-cct.ai

Precision triac control thermostat

OM1682 OM1682A

11 PACKAGE OUTLINES

SO16: plastic small outline package; 16 leads; body width 3.9 mm

SOT109-1

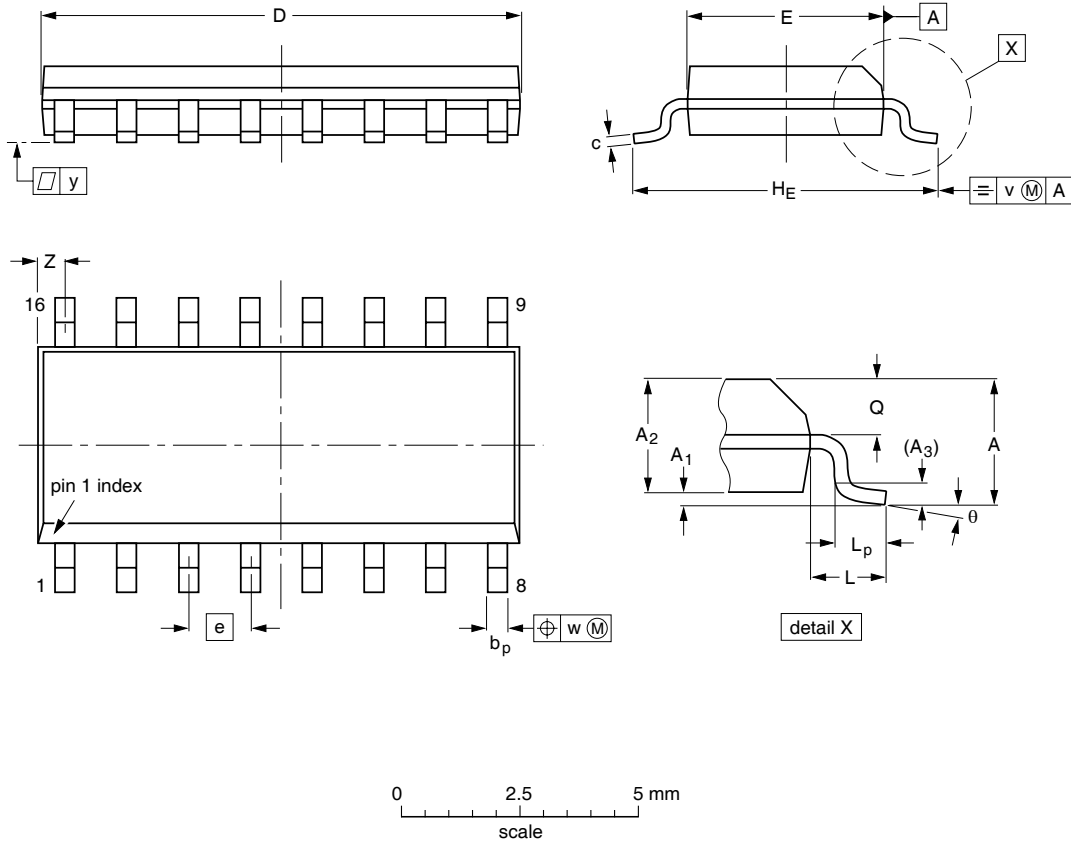

DIMENSIONS (inch dimensions are derived from the original mm dimensions)

UNIT	A ₁ max.	A ₁	A ₂	A ₃	b _p	c	D ⁽¹⁾	E ⁽¹⁾	e	H _E	L	L _p	Q	v	w	y	Z ⁽¹⁾	θ
mm	1.75	0.25 0.10	1.45 1.25	0.25	0.49 0.36	0.25 0.19	10.0 9.8	4.0 3.8	1.27	6.2 5.8	1.05	1.0 0.4	0.7 0.6	0.25	0.25	0.1	0.7 0.3	8° 0°
inches	0.069	0.010 0.004	0.057 0.049	0.01	0.019 0.014	0.010 0.0075	0.39 0.38	0.16 0.15	0.050	0.244 0.228	0.041	0.039 0.016	0.028 0.020	0.01	0.01	0.004	0.028 0.012	

Note

1. Plastic or metal protrusions of 0.15 mm maximum per side are not included.

OUTLINE VERSION	REFERENCES				EUROPEAN PROJECTION	ISSUE DATE
	IEC	JEDEC	EIAJ			
SOT109-1	076E07S	MS-012AC				95-01-23 97-05-22

Precision triac control thermostat

OM1682 OM1682A

DIP16: plastic dual in-line package; 16 leads (300 mil); long body

SOT38-1

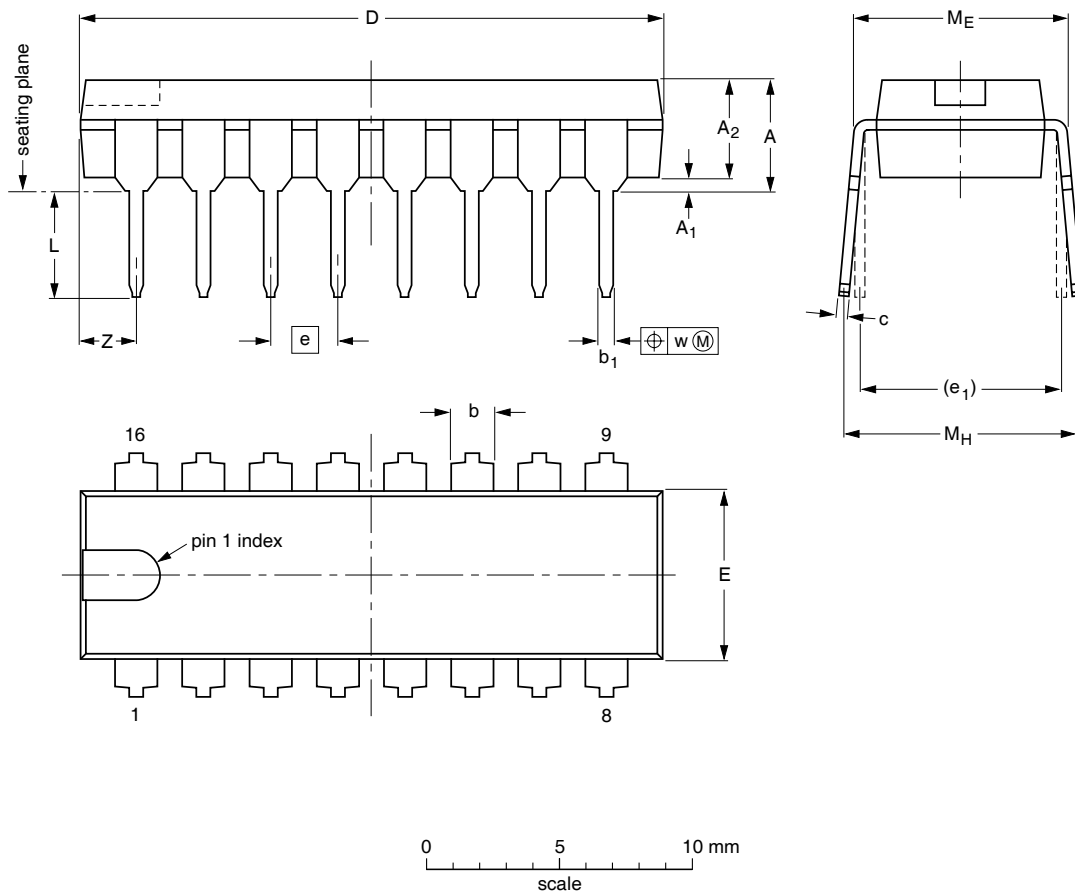

DIMENSIONS (inch dimensions are derived from the original mm dimensions)

UNIT	A max.	A ₁ min.	A ₂ max.	b	b ₁	c	D ⁽¹⁾	E ⁽¹⁾	e	e ₁	L	M _E	M _H	w	Z ⁽¹⁾ max.
mm	4.7	0.51	3.7	1.40 1.14	0.53 0.38	0.32 0.23	21.8 21.4	6.48 6.20	2.54	7.62	3.9 3.4	8.25 7.80	9.5 8.3	0.254	2.2
inches	0.19	0.020	0.15	0.055 0.045	0.021 0.015	0.013 0.009	0.86 0.84	0.26 0.24	0.10	0.30	0.15 0.13	0.32 0.31	0.37 0.33	0.01	0.087

Note

1. Plastic or metal protrusions of 0.25 mm maximum per side are not included.

OUTLINE VERSION	REFERENCES				EUROPEAN PROJECTION	ISSUE DATE
	IEC	JEDEC	EIAJ			
SOT38-1	050G09	MO-001AE				92-10-02 95-01-19

Precision triac control thermostat

OM1682 OM1682A

12 SOLDERING

12.1 Introduction

There is no soldering method that is ideal for all IC packages. Wave soldering is often preferred when through-hole and surface mounted components are mixed on one printed-circuit board. However, wave soldering is not always suitable for surface mounted ICs, or for printed-circuits with high population densities. In these situations reflow soldering is often used.

This text gives a very brief insight to a complex technology. A more in-depth account of soldering ICs can be found in our *"IC Package Data book"* (order code 9398 652 90011).

12.2 DIP

12.2.1 SOLDERING BY DIPPING OR BY WAVE

The maximum permissible temperature of the solder is 260 °C; solder at this temperature must not be in contact with the joint for more than 5 seconds. The total contact time of successive solder waves must not exceed 5 seconds.

The device may be mounted up to the seating plane, but the temperature of the plastic body must not exceed the specified maximum storage temperature ($T_{stg\ max}$). If the printed-circuit board has been pre-heated, forced cooling may be necessary immediately after soldering to keep the temperature within the permissible limit.

12.2.2 REPAIRING SOLDERED JOINTS

Apply a low voltage soldering iron (less than 24 V) to the lead(s) of the package, below the seating plane or not more than 2 mm above it. If the temperature of the soldering iron bit is less than 300 °C it may remain in contact for up to 10 seconds. If the bit temperature is between

300 and 400 °C, contact may be up to 5 seconds.

12.3 SO

12.3.1 REFLOW SOLDERING

Reflow soldering techniques are suitable for all SO packages.

Reflow soldering requires solder paste (a suspension of fine solder particles, flux and binding agent) to be applied to the printed-circuit board by screen printing, stencilling or pressure-syringe dispensing before package placement.

Several techniques exist for reflowing; for example, thermal conduction by heated belt. Dwell times vary between 50 and 300 seconds depending on heating method. Typical reflow temperatures range from 215 to 250 °C.

Preheating is necessary to dry the paste and evaporate the binding agent. Preheating duration: 45 minutes at 45 °C.

12.3.2 WAVE SOLDERING

Wave soldering techniques can be used for all SO packages if the following conditions are observed:

- A double-wave (a turbulent wave with high upward pressure followed by a smooth laminar wave) soldering technique should be used.
- The longitudinal axis of the package footprint must be parallel to the solder flow.
- The package footprint must incorporate solder thieves at the downstream end.

During placement and before soldering, the package must be fixed with a droplet of adhesive. The adhesive can be applied by screen printing, pin transfer or syringe

dispensing. The package can be soldered after the adhesive is cured.

Maximum permissible solder temperature is 260 °C, and maximum duration of package immersion in solder is 10 seconds, if cooled to less than 150 °C within 6 seconds. Typical dwell time is 4 seconds at 250 °C.

A mildly-activated flux will eliminate the need for removal of corrosive residues in most applications.

12.3.3 REPAIRING SOLDERED JOINTS

Fix the component by first soldering two diagonally- opposite end leads. Use only a low voltage soldering iron (less than 24 V) applied to the flat part of the lead. Contact time must be limited to 10 seconds at up to 300 °C. When using a dedicated tool, all other leads can be soldered in one operation within 2 to 5 seconds between 270 and 320 °C.

Precision triac control thermostat

OM1682 OM1682A

Notes:

Precision triac control thermostat

OM1682 OM1682A

Notes:

Precision triac control thermostat

OM1682 OM1682A

13 DEFINITIONS

Data sheet status	
Engineering sample information	This contains draft information describing an engineering sample provided to demonstrate possible function and feasibility. Engineering samples have no guarantee that they will perform as described in all details.
Objective specification	This data sheet contains target or goal specifications for product development. Engineering samples have no guarantee that they will function as described in all details.
Preliminary specification	This data sheet contains preliminary data; supplementary data may be published later. Products to this data may not yet have been fully tested, and their performance fully documented.
Product specification	This data sheet contains final product specifications.
Limiting values	
Limiting values given are in accordance with the Absolute Maximum Rating System (IEC 134). Stress above one or more of the limiting values may cause permanent damage to the device. These are stress ratings only and operation of the device at these or at any other conditions above those given in the Characteristics sections of the specification is not implied. Exposure to limiting values for extended periods may affect device reliability.	
Application information	
Where application information is given, it is advisory and does not form part of the specification.	

14 IES INFORMATION

INTEGRATED ELECTRONIC SOLUTIONS PTY. LTD.
 ABN 17 080 879 616

Postal address:

Integrated Electronic Solutions
 PO Box 2226
 Port Adelaide SA 5015
 AUSTRALIA

Street Address:

Integrated Electronic Solutions
 1 Butler Drive
 Hendon SA 5014
 AUSTRALIA

Telephone: +61 8 8348 5200
 Facsimile: +61 8 8243 1048

World Wide Web: www.integratedelectronicsolutions.com

Email: IES@ies.sa.com.au

Precision triac control thermostat**OM1682 OM1682A**

15 DISCLAIMER

Integrated Electronic Solutions Pty. Ltd. ABN 17 080 879 616 ("IES") reserves the right to make changes to both its products and product data without notice.

IES makes no warranty, representation or guarantee regarding the suitability of its products for any particular purpose, nor does IES assume any liability arising out of the use or application of any IES product. IES specifically disclaims any and all liability, including without limitation incidental or consequential damages.

Typical performance figures, where quoted may depend on the application and therefore must be validated by the customer in each particular application. It is the responsibility of customers to ensure that any designs using IES products comply with good practice, applicable standards and approvals. IES accepts no responsibility for incorrect or non-compliant use of its products, failure to meet appropriate standards and approvals in the application of IES products, or for the correct engineering choice of other connected components, layout and operation of IES products.

Any customer purchasing or using IES product(s) for an unintended or unauthorised application shall indemnify and hold IES and its officers, employees, related companies, affiliates and distributors harmless against all claims, costs, damages, expenses, and reasonable legal fees arising out of, directly or indirectly, any claim of loss, personal injury or death associated with such unintended or unauthorised use, even if such claim alleges that IES was negligent regarding the design or manufacture of the relevant product(s).

Life Support Applications

Products of Integrated Electronic Solutions Pty Ltd (IES) are not designed for use in life support appliances, devices or systems, where malfunction can result in personal injury. Customers using or selling IES products for use in such applications do so at their own risk and agree to fully indemnify IES for any damages resulting from such improper use or sale.