



# SANYO Semiconductors DATA SHEET

## LA1652C — Monolithic Linear IC Time Code Reception IC

### Overview

The LA1652C time code reception IC receives long-wave time standard broadcasts (such as the Japanese JJY and German DCF77 standards) and detects and outputs the time code superposed on the long-wave signal.

Applications can automatically correct their clock's time setting by using the time code received by the LA1652C. Note that the LA1652C is a bare chip product that is not packaged.

### Functions

- RF amplifier, rectifier, detector, time code output, and standby circuit.

### Features

- Low-voltage operation (operating  $V_{CC}$  as low as 1.8V).
- Standby mode current drain less than or equal to 0.1 $\mu$ A.  
Japan : JJY 40/60kHz  
Germany : DCF77 77.5kHz

### Specifications

#### Maximum Ratings at $T_a = 25^\circ\text{C}$

Parameter	Symbol	Conditions	Ratings	Unit
Maximum supply voltage	$V_{CC\ max}$		5.0	V
Operating temperature	$T_{opr}$		-20 to +70	$^\circ\text{C}$
Storage temperature	$T_{stg}$		-40 to +125	$^\circ\text{C}$

#### Operating Conditions at $T_a = 25^\circ\text{C}$

Parameter	Symbol	Conditions	Ratings			Unit
			min	typ	max	
Recommended supply voltage	$V_{CC}$			3.0		V
Operating supply voltage range	$V_{CC\ op}$		1.8		3.6	V

- Any and all SANYO Semiconductor products described or contained herein do not have specifications that can handle applications that require extremely high levels of reliability, such as life-support systems, aircraft's control systems, or other applications whose failure can be reasonably expected to result in serious physical and/or material damage. Consult with your SANYO Semiconductor representative nearest you before using any SANYO Semiconductor products described or contained herein in such applications.
- SANYO Semiconductor assumes no responsibility for equipment failures that result from using products at values that exceed, even momentarily, rated values (such as maximum ratings, operating condition ranges, or other parameters) listed in products specifications of any and all SANYO Semiconductor products described or contained herein.

**SANYO Semiconductor Co., Ltd.**

TOKYO OFFICE Tokyo Bldg., 1-10, 1 Chome, Ueno, Taito-ku, TOKYO, 110-8534 JAPAN

# LA1652C

## Operating Characteristics at $T_a = 25^\circ\text{C}$ , $V_{CC} = 3.0\text{V}$

\* : Packaged in an SSOP16 package and measured using the IC51-0162-911 socket (Yamaichi Electronics Co., Ltd.)

### Overall Characteristics

Parameter	Symbol	Conditions	Ratings			Unit
			min	typ	max	
Quiescent current	$I_{CCO}$	No input		55	70	$\mu\text{A}$
Standby mode current drain	$I_{STB}$	PAD15 = 3.0V		0.01	0.1	$\mu\text{A}$

### Amplifier Input Characteristics

Parameter	Symbol	Conditions	Ratings			Unit
			min	typ	max	
Input impedance	$Z_I$	PAD1		2.0		$\text{M}\Omega$
Input frequency range	$F_{IN}$		37.5		80.0	kHz
Minimum input voltage	$V_{MIN}$	PAD1 input level		1	2	$\mu\text{V}_{rms}$
Maximum input voltage	$V_{MAX}$	PAD1 input level	50	100		$\text{mV}_{rms}$

### TCO Output Characteristics - Input pad = PAD1, $f_{in} = 40\text{kHz}$

Parameter	Symbol	Conditions	Ratings			Unit
			min	typ	max	
High-level output voltage	$V_{OH}$		2.90	2.95		V
Low-level output voltage	$V_{OL}$			0.05	0.10	V
Output pulse width (500 ms input)	T500	$V_{IN} = 0$ to 100dB $\mu\text{V}$ , AM modulation (1Hz square wave, duty = 50%, 10:1 modulation)	350	450	550	ms
Output pulse width (800 ms input)	T800	$V_{IN} = 0$ to 100dB $\mu\text{V}$ , AM modulation (1Hz square wave, duty = 80%, 10:1 modulation)	650	750	850	ms
Output pulse width (200 ms input)	T200	$V_{IN} = 0$ to 100dB $\mu\text{V}$ , AM modulation (1Hz square wave, duty = 20%, 10:1 modulation)	100	200	300	ms

# LA1652C

## Chip Specifications

Parameter	Conditions	Ratings	Unit
Chip size		1.73×2.60	mm <sup>2</sup>
Chip thickness		330(±20)	μm
Pad size		140×140	μm <sup>2</sup>
Pad opening		115×115	μm <sup>2</sup>

## PAD Coordinates

PAD	X-Axis	Y-Axis	PAD	X-Axis	Y-Axis
P1	664	150	P9	1293	2450
P2	180	180	P10	1580	2330
P3A	150	864	P11	1580	2103
P3B	150	372	P12	1580	1754
P4	150	1034	P13	1580	1360
P5	150	1563	P14	1580	1108
P6A	150	2269	P15	1570	160
P6B	150	1733	P16	974	150
P7	160	2440			
P8	876	2450			

### Notes

1. The left upper corner of the Pad Layout Diagram on the following page is the origin, the X axis increases to the right and the Y axis increases in the downward direction.
2. Units : μm
3. The pad coordinates give the coordinate values of the center of the pads.
4. Both of each of the pairs P3A/P3B (V<sub>CC</sub>) and P6A/P6B (ground) must be bonded.

# LA1652C

## Pad Layout Diagram

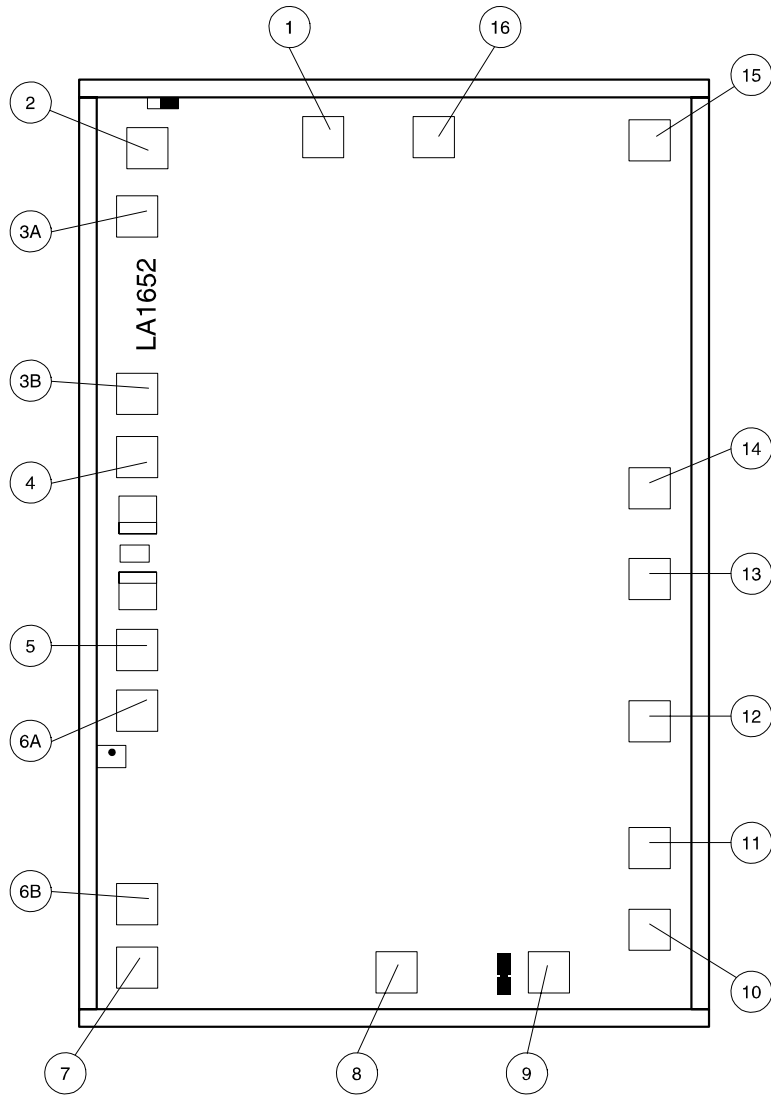

PCA00615

## Block Diagram

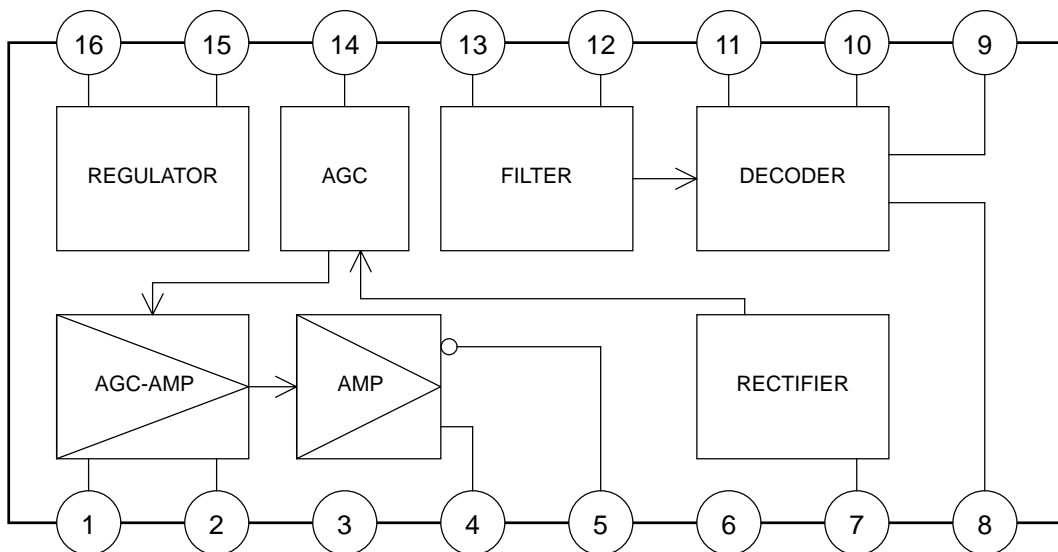

PCA00616

# LA1652C

## Test Circuit Diagram

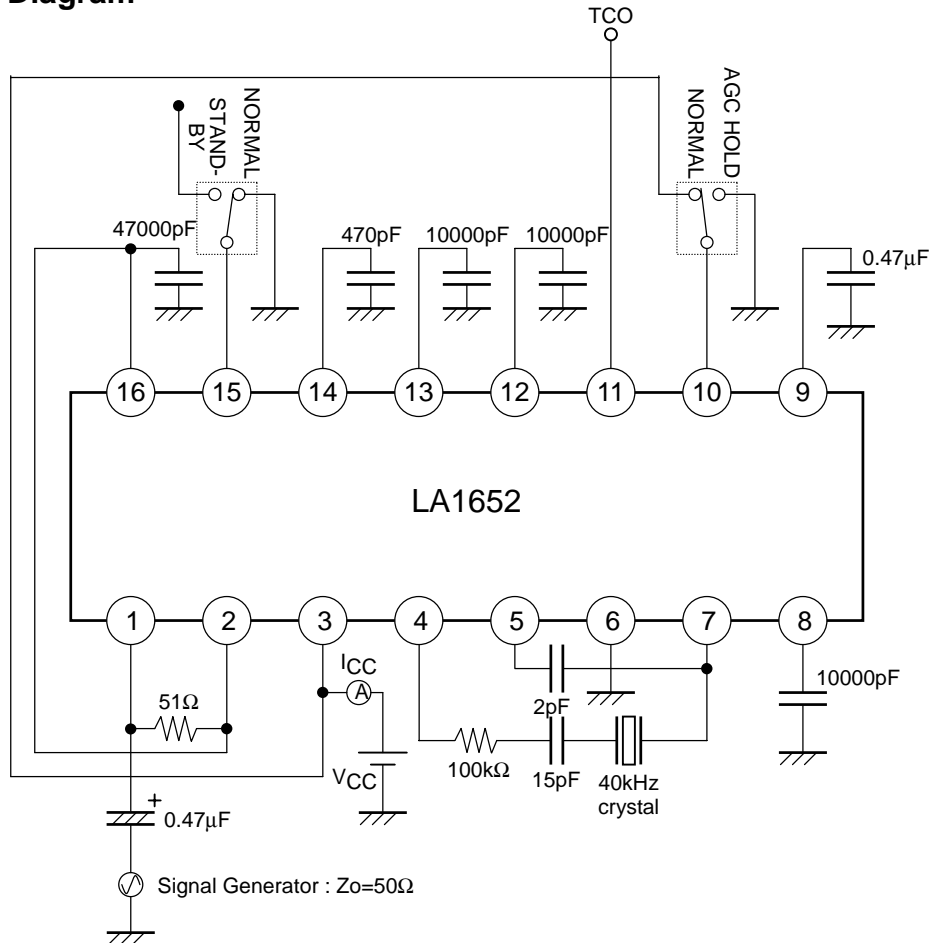

PCA00617

- Specifications of any and all SANYO Semiconductor products described or contained herein stipulate the performance, characteristics, and functions of the described products in the independent state, and are not guarantees of the performance, characteristics, and functions of the described products as mounted in the customer's products or equipment. To verify symptoms and states that cannot be evaluated in an independent device, the customer should always evaluate and test devices mounted in the customer's products or equipment.
- SANYO Semiconductor Co., Ltd. strives to supply high-quality high-reliability products. However, any and all semiconductor products fail with some probability. It is possible that these probabilistic failures could give rise to accidents or events that could endanger human lives, that could give rise to smoke or fire, or that could cause damage to other property. When designing equipment, adopt safety measures so that these kinds of accidents or events cannot occur. Such measures include but are not limited to protective circuits and error prevention circuits for safe design, redundant design, and structural design.
- In the event that any or all SANYO Semiconductor products (including technical data, services) described or contained herein are controlled under any of applicable local export control laws and regulations, such products must not be exported without obtaining the export license from the authorities concerned in accordance with the above law.
- No part of this publication may be reproduced or transmitted in any form or by any means, electronic or mechanical, including photocopying and recording, or any information storage or retrieval system, or otherwise, without the prior written permission of SANYO Semiconductor Co., Ltd.
- Any and all information described or contained herein are subject to change without notice due to product/technology improvement, etc. When designing equipment, refer to the "Delivery Specification" for the SANYO Semiconductor product that you intend to use.
- Information (including circuit diagrams and circuit parameters) herein is for example only; it is not guaranteed for volume production. SANYO Semiconductor believes information herein is accurate and reliable, but no guarantees are made or implied regarding its use or any infringements of intellectual property rights or other rights of third parties.

This catalog provides information as of January, 2006. Specifications and information herein are subject to change without notice.