

# MBRS10H100CT - MBRS10H200CT

## 10.0 AMPS. Surface Mount Schottky Barrier Rectifiers Switchmode Power Rectifiers

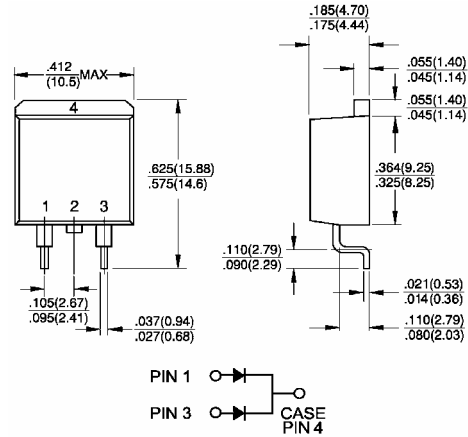

### D<sup>2</sup>PAK



Dimensions in inches and (millimeters)

### Features

- ✧ Plastic material used carries Underwriters Laboratory Classifications 94V-0
- ✧ Metal silicon junction, majority carrier conduction
- ✧ Low power loss, high efficiency
- ✧ High current capability, low forward voltage drop
- ✧ High surge capability
- ✧ For use in low voltage, high frequency inverters, free wheeling, and polarity protection applications
- ✧ Guardring for overvoltage protection
- ✧ High temperature soldering guaranteed: 260°C/10 seconds, 0.25" (6.35mm) from case

### Mechanical Data

- ✧ Cases: D2PAK molded plastic
- ✧ Terminals: Pure tin plated, lead free. solderable per MIL-STD-750, Method 2026
- ✧ Polarity: As marked
- ✧ Mounting position: Any
- ✧ Mounting torque: 5 in. - lbs. max
- ✧ Weight: 0.08 ounce, 2.24 grams

### Maximum Ratings and Electrical Characteristics

Rating at 25 °C ambient temperature unless otherwise specified.

Single phase, half wave, 60 Hz, resistive or inductive load.

For capacitive load, derate current by 20%

Type Number	Symbol	MBRS 10H100CT	MBRS 10H150CT	MBRS 10H200CT	Units
Maximum Recurrent Peak Reverse Voltage	$V_{RRM}$	100	150	200	V
Maximum RMS Voltage	$V_{RMS}$	70	105	140	V
Maximum DC Blocking Voltage	$V_{DC}$	100	150	200	V
Maximum Average Forward Rectified Current at $T_C=133^{\circ}C$	$I_{(AV)}$	10			A
Peak Repetitive Forward Current (Rated $V_R$ , Square Wave, 20KHz) at $T_C=133^{\circ}C$	$I_{FRM}$	10			A
Peak Forward Surge Current, 8.3 ms Single Half Sine-wave Superimposed on Rated Load (JEDEC method)	$I_{FSM}$	120			A
Peak Repetitive Reverse Surge Current (Note 1)	$I_{RRM}$	1.0		0.5	A
Maximum Instantaneous Forward Voltage at (Note 2) $I_F=5A, T_C=25^{\circ}C$ $I_F=5A, T_C=125^{\circ}C$ $I_F=10A, T_C=25^{\circ}C$ $I_F=10A, T_C=125^{\circ}C$	$V_F$	0.85 0.75 0.95 0.85	0.88 0.75 0.97 0.85		V
Maximum Instantaneous Reverse Current at Rated DC Blocking Voltage @ $T_C=25^{\circ}C$ @ $T_C=125^{\circ}C$	$I_R$	5.0 1.0			$\mu A$ mA
Voltage Rate of Change, (Rated $V_R$ )	dV/dt	10,000			V/ $\mu S$
RMS Isolation Voltage (t=1.0 second, R.H. $\leq 30\%$ , $T_A=25^{\circ}C$ ) (Note 4) (Note 5) (Note 6)	$V_{ISO}$	4500 3500 1500			V
Typical Thermal Resistance Per Leg (Note3)	$R_{\theta JC}$	3.5			$^{\circ}C/W$
Operating Junction Temperature Range	$T_J$	-65 to +175			$^{\circ}C$
Storage Temperature Range	$T_{STG}$	-65 to +175			$^{\circ}C$

- Notes:
1. 2.0  $\mu s$  Pulse Width, f=1.0 KHz
  2. Pulse Test: 300 $\mu s$  Pulse Width, 1% Duty Cycle
  3. Thermal Resistance from Junction to Case Per Leg.
  4. Clip Mounting (on case), where lead does not overlap heatsink with 0.110" offset.
  5. Clip mounting (on case), where leads do overlap heatsink.
  6. Screw mounting with 4-40 screw, where washer diameter is  $\leq 4.9$  mm (0.19")

## RATINGS AND CHARACTERISTIC CURVES (MBS10H100CT - MBS10H200CT)

FIG.1- FORWARD CURRENT DERATING CURVE

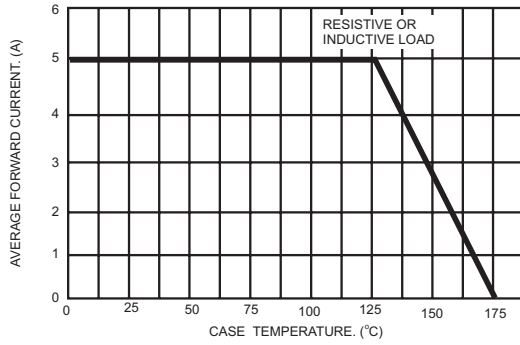

FIG.2- MAXIMUM NON-REPETITIVE FORWARD SURGE CURRENT

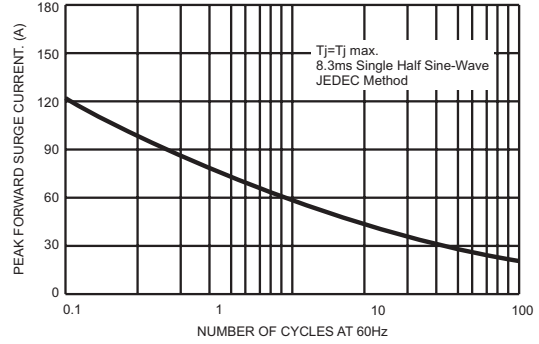

FIG.3- TYPICAL INSTANTANEOUS FORWARD CHARACTERISTICS

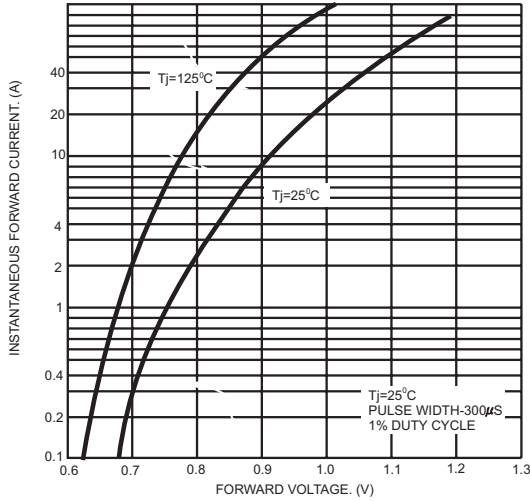

FIG.4- TYPICAL REVERSE CHARACTERISTICS

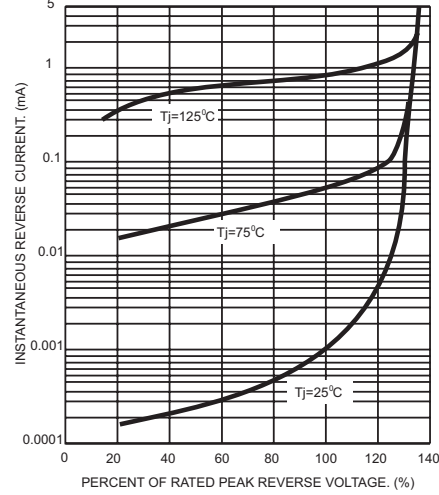

FIG.5- TYPICAL JUNCTION CAPACITANCE

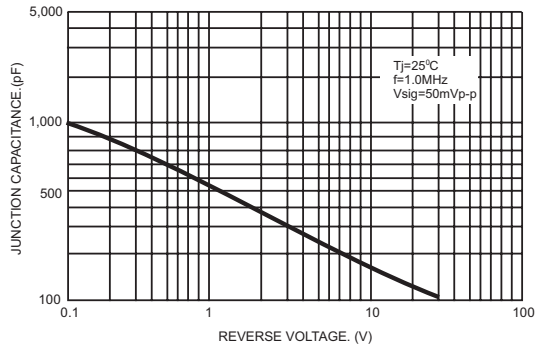

FIG.6- TYPICAL TRANSIENT THERMAL CHARACTERISTICS PER LEG

