

LCD MODULE SPECIFICATION

Products Name: APAX T10C1
10.4 INCH (800x600)
COLOR TFT LCD MODULE
3.3V

- **Preliminary Specification**

This technical specification is tentative and it will be changed without notice.

進金生實業股份有限公司

台北市內湖區瑞光路76巷39號4樓

Tel:02-87912868 Fax:02-87912869

Version. 1.0

CONTENTS

REVISION HISTORY

GENERAL DESCRIPTION

1. ABSOLUTE MAXIMUM RATINGS

1.1 ABSOLUTE RATINGS OF ENVIRONMENT

1.2 ELECTRICAL ABSOLUTE RATINGS

2. ELECTRICAL SPECIFICATIONS

2.1 TFT LCD MODULE

2.2 BACKLIGHT UNIT

3. BLOCK DIAGRAM

3.1 TFT LCD MODULE

3.2 BACKLIGHT UNIT

4. INTERFACE SPECIFICATIONS

4.1 THE PIN ASSIGNMENT OF LVDS INTERFACE CONNECTOR

4.2 INPUT SIGNAL TIMING SPECIFICATIONS

4.3 COLOR DATA INPUT ASSIGNMENT

4.4 POWER UP/DOWN SEQUENCE

5. OPTICAL CHARACTERISTICS

5.1 TEST CONDITIONS

5.2 OPTICAL SPECIFICATIONS

6. MECHANICAL DRAWING

7. PRECAUTION

7.1 ASSEMBLY AND HANDLING PRECAUTION

7.2 SAFETY PRECAUTION

REVISION HISTORY

Version	Date	Description
Ver 0.0	Aug. 29, '00	Tentative Specification was First Issued for CMO internal use only.
Ver 0.1	Oct. 16, '00	<ol style="list-style-type: none"> 1. All new specification formats. 2. Changing module outline dimensions & bezel opening area from 224.5x173.4mm and 214.4x162.0mm to 224.5x172.0mm and 214.2x161.8mm on page 4/19 and attached drawings. 3. Fixed interface connector P/N: DF19KR-20P-1H (Hirose) on page 9/19 and attached drawings. 4. Interface pin assignment: Pin 17 to Pin 20 connect to ground on page 9/19. 5. Adding input signal timing specifications on pages 10/19 and 11/19.

GENERAL DESCRIPTION

OVERVIEW

This product is a 10.4" TFT Liquid Crystal Display Module with 1 edge CCFL Backlight unit and 20 pins LVDS interface. This module supports 800 x 600 SVGA mode and can display 262,144 colors. The inverter module for Backlight is not built in.

FEATURES

- SVGA (800x600 pixels) resolution
- 1 edge CCFL (Cold Cathode Fluorescent Lamp)
- Standard Mode
- LVDS (Low Voltage Differential Signaling) Interface

APPLICATION

- IA (Information Appliance) & TFT-LCD Notebook PC

GENERAL SPECIFICATIONS

Item	Spec.	Unit
Screen Size	10.4 Diagonal	inch
Bezel Opening Area	214.2(H)X161.8(V)	mm
Effective Display Area	211.2(H)x158.4(V)	mm
Driver Element	a-si TFT active matrix	-
Pixel Number	800xR.G.B.x600	pixel
Pixel Pitch	0.264(H)x0.264(W)	mm
Pixel Arrangement	RGB vertical stripe	-
Display Colors	6 bits, 262,144	color
Transmissive Mode	Normally White	-
Surface Treatment	Haze 12Hard-Coating, Anti-static	-

MECHANICAL SPECIFICATIONS

Item	Min.	Typ.	Max.	Unit	Note	
Module Size	Horizontal(H)	(224.0)	224.5	(225.0)	mm	
	Vertical(V)	(171.5)	172.0	(172.5)	mm	
	Depth(D)	-	(5.7)	6	mm	
Weight	-	-	(310)	g		

1. ABSOLUTE MAXIMUM RATINGS

1.1 ABSOLUTE RATINGS OF ENVIRONMENT

Item	Symbol	Values		Unit	Note
		Min.	Max.		
Storage temperature	Tst	-20	+60	°C	(1)
Operating temperature (Ambient Temperature)	Top	0	+50	°C	(1)
Shock(non-operating)	Snop	-	50	G	(2),(4)
Vibration(non-operating)	Vnop	-	1.5	G	(3),(4)

Note (1) Temperature and relative humidity range is shown in the figure below.

90% RH Max. ($T_a \leq 40^\circ\text{C}$).

Maximum wet-bulb temperature at 39°C or less. ($T_a > 40^\circ\text{C}$) No condensation.

Note (2) 11ms, half-sine wave, three times for $\pm X$, $\pm Y$, $\pm Z$.

Note (3) 10-500 Hz, 30min/cycle, for X, Y, Z direction, each 2 Hrs.

Note (4) At testing Vibration and Shock, the fixture in holding the Module to be tested has to be hard and rigid enough so that the Module would not be twisted or bent by the fixture.

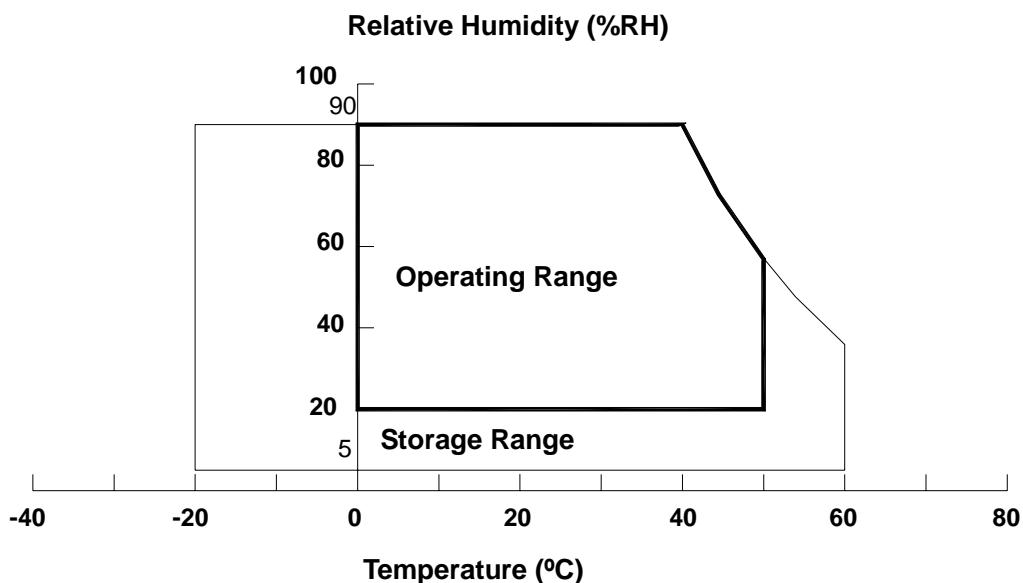

1.2 ELECTRICAL ABSOLUTE RATINGS

(1) TFT LCD MODULE

Item	Symbol	Values		Unit	Note
		Min.	Max.		
Power Supply Voltage	V _{CC}	V _{SS} - 0.3	+ 4.0	V	Ta = 25 ± 2 °C
Logic Input Voltage	V _{IN}	V _{SS} - 0.3	V _{CC} + 0.3	V	

(2)BACKLIGHT UNIT

Item	Symbol	Value		Unit	Note
		Min.	Max.		
Lamp Current	I_L	-	6.0	mA_{RMS}	(1),(2)
Lamp Frequency	F_L	-	80	KHZ	(1)

Note (1) Permanent damage to device may occur if maximum values are exceeded. Function operation should be restricted to the conditions described under Normal Operating Conditions.

Note (2) Specified values are for lamp (Refer to 2.2 for further information).

2. ELECTRICAL SPECIFICATIONS

2.1 TFT LCD MODULE

MODULE							
Parameter	Symbol	Value			Unit	Note	
		Min.	Typ.	Max.			
Power Supply Voltage	V_{CC}	(3.0)	(3.3)	(3.6)	V	-	
Power Supply Current	I_{CC}	-	TBD	TBD	mA	(1)	
Ripple Voltage	V_{rp}	-	(100)	-	mV	-	
Differential Input Voltage for LVDS Receiver Threshold	High	V_{IH}	-	-	+100	V	-
	Low	V_{IL}	-100	-	-	V	-
Rush Current	I_{rush}	-	-	TBD	A	(2)	

Note (1) Operating Temp. range is 0 ~ 50 °C, and the value of power supply current is measured in black pattern.

Note (2) Measurement Conditions

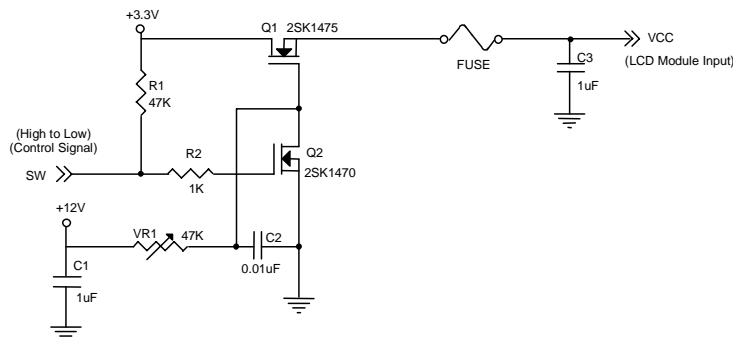

VCC rising time is 470us

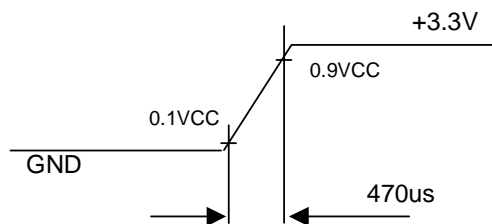

2.2 BACKLIGHT UNIT

BACKLIGHT (one CCFL)						
Parameter	Symbol	Value			Unit	Note
		Min.	Typ.	Max.		
Lamp Input Voltage	V_L	(510)	(560)	(610)	V_{RMS}	$I_L=4.3mA$
Lamp Current	I_L	(2.0)	(4.3)	(6.0)	mA_{RMS}	(1)
Lamp Turn On Voltage	V_S	-	-	(800)(25°C)	V_{RMS}	(2)
		-	-	(1050)(0 °C)	V_{RMS}	(2)
Operating Frequency	F_L	(40)	(55)	(80)	KHz	(3)
Lamp Life Time	L_{BL}	10,000	(25,000)	-	Hrs	(5)
Power Consumption	P_L	-	(2.4)	-	W	(4), $I_L=4.3mA$

Note (1) Lamp current is measured by utilizing a current meter for high frequency as shown below:

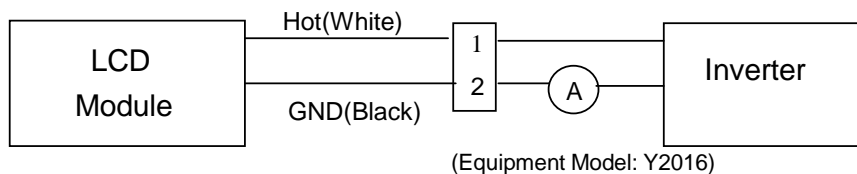

Note (2) The voltage shown above should be applied to the lamp for more than 1 second after startup. Otherwise the lamp may not be turned on.

Note (3) The lamp frequency may produce interference with horizontal synchronous frequency from the display, and this may cause line flow on the display. In order to avoid interference the lamp frequency should be detached from the horizontal synchronous frequency and its harmonics as far as possible.

Note (4) $P_L = I_L \times V_L$.

Note (5) The lifetime (Hr) of a lamp can be defined as the time in which it continues to operate under the condition $T_a = 25 \pm 2^\circ C$ and $I_L = 5.0 mA_{RMS}$ until one of the following event occurs:

- (a) When the brightness becomes 50% or lower than its original,
- (b) When the effective ignition length becomes 80% or lowers than its original value. (Effective ignition length is defined as an area that has less than 70% brightness compared to the brightness in the center point.)

Note (6) The waveform of the voltage output of inverter must be area-symmetric and the design of the inverter must have specifications for the modularized lamp. The performance of the backlight, such as lifetime or brightness, is greatly influenced by the characteristics of the DC-AC inverter for the lamp. All the parameters of an inverter should be designed with care so as not to produce too much current leakage from high-voltage output of the inverter. When designing or ordering the inverter please make sure that a poor lighting caused by the mismatch of the backlight and the inverter (miss-lighting, flicker, etc.) never occurs. When the above situation is confirmed, the module should be operated in the same manners as it is installed in your instrument.

The connector information of Backlight unit.

Pin	Symbol	Description	Remark
1	HV	High Voltage	White
2	LV	Ground	Black

Note (1) Connector Part No.: BHSR-02VS-1 (JST)

Note (2) User's connector Part No.: SM02B-BHSS-1-TB (JST)

3. BLOCK DIAGRAM

3.1 TFT LCD MODULE

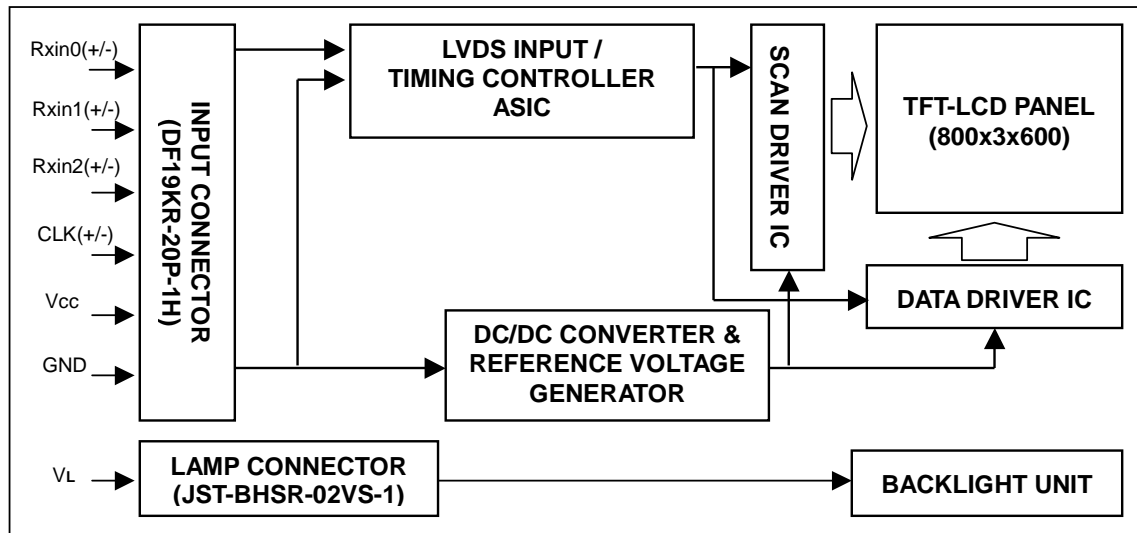

3.2 BACKLIGHT UNIT

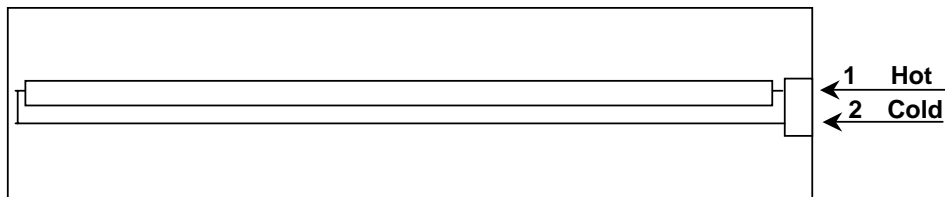

4. INTERFACE SPECIFICATIONS

4.1 THE PIN ASSIGNMENT OF LVDS INTERFACE CONNECTOR

Pin	Symbol	Description	Notes
1	V _{CC}	Power supply +3.3 v	-
2	V _{CC}	Power supply +3.3 v	-
3	V _{SS}	Ground	-
4	V _{SS}	Ground	-
5	Rxin0-	LVDS differential data input (Negative)	R0~R5,G0
6	Rxin0+	LVDS differential data input (Positive)	
7	V _{SS}	Ground	-
8	Rxin1-	LVDS differential data input (Negative)	G1~G5,B0,B1
9	Rxin1+	LVDS differential data input (Positive)	
10	V _{SS}	Ground	-
11	Rxin2-	LVDS differential data input (Negative)	B2~B5,DE,Hsync, Vsync
12	Rxin2+	LVDS differential data input (Positive)	
13	V _{SS}	Ground	-
14	CLK-	LVDS Clock Data input (Negative)	LVDS level
15	CLK+	LVDS Clock Data input (Positive)	
16	V _{SS}	Ground	-
17	GND	Ground	-
18	GND	Ground	-
19	GND	Ground	-
20	GND	Ground	-

Note (1) Connector Part No.: DF19KR-20P-1H (Hirose) or equivalent

Note (2) User's connector Part No: DF19G-20S-1C (Wire), DF19G-20S-1F-GND (FPC) or
DF19G-20S-1SD-GND (Co-Axial cable)

4.2 INPUT SIGNAL TIMING SPECIFICATIONS

The specifications of input signal timing are as the following table and timing diagram.

Signal	Parameter	Symbol	Min	Typ	Max	Unit	Remarks
DCLK	Pixel clock period	Tck	-	25	-	ns	
	Duty ratio (%Tch)	-	TBD	50	TBD	%	Tch/Tck
	Rise time	Trck	-	TBD	TBD	ns	
	Fall time	Tfck	-	TBD	TBD	ns	
DATA	Setup time	Tsd	TBD	TBD	-	ns	
	Hold time	Thd	TBD	TBD	-	ns	
	Rise time	Trd	-	TBD	-	ns	
	Fall time	Tfd	-	TBD	-	ns	
DE	Setup time	Tsde	TBD	TBD	-	ns	
	Hold time	Thde	TBD	TBD	-	ns	
VSYNC	Vertical period	Tvp	TBD	628	TBD	Thp	
	Vertical display blank period	Tvdb	TBD	28	TBD	Thp	
	Vertical display active period	Tvda	600	600	600	Thp	
	Vertical sync. back porch	Vbp	TBD	23	TBD	Thp	
	Vertical sync. front porch	Vfp	TBD	TBD	TBD	Thp	
	Vertical sync. pulse width	Vpw	TBD	4	TBD	Thp	
HSYNC	Horizontal period	Thp	TBD	1056	TBD	Tck	
	Horizontal display blank period	Thdb	TBD	256	TBD	Tck	
	Horizontal display active period	Thda	800	800	800	Tck	
	Horizontal sync. back porch	Hbp	TBD	88	TBD	Tck	
	Horizontal sync. front porch	Hfb	TBD	TBD	TBD	Tck	
	Horizontal sync. pulse width	Hpw	TBD	128	TBD	Tck	

INPUT SIGNAL TIMING DIAGRAM

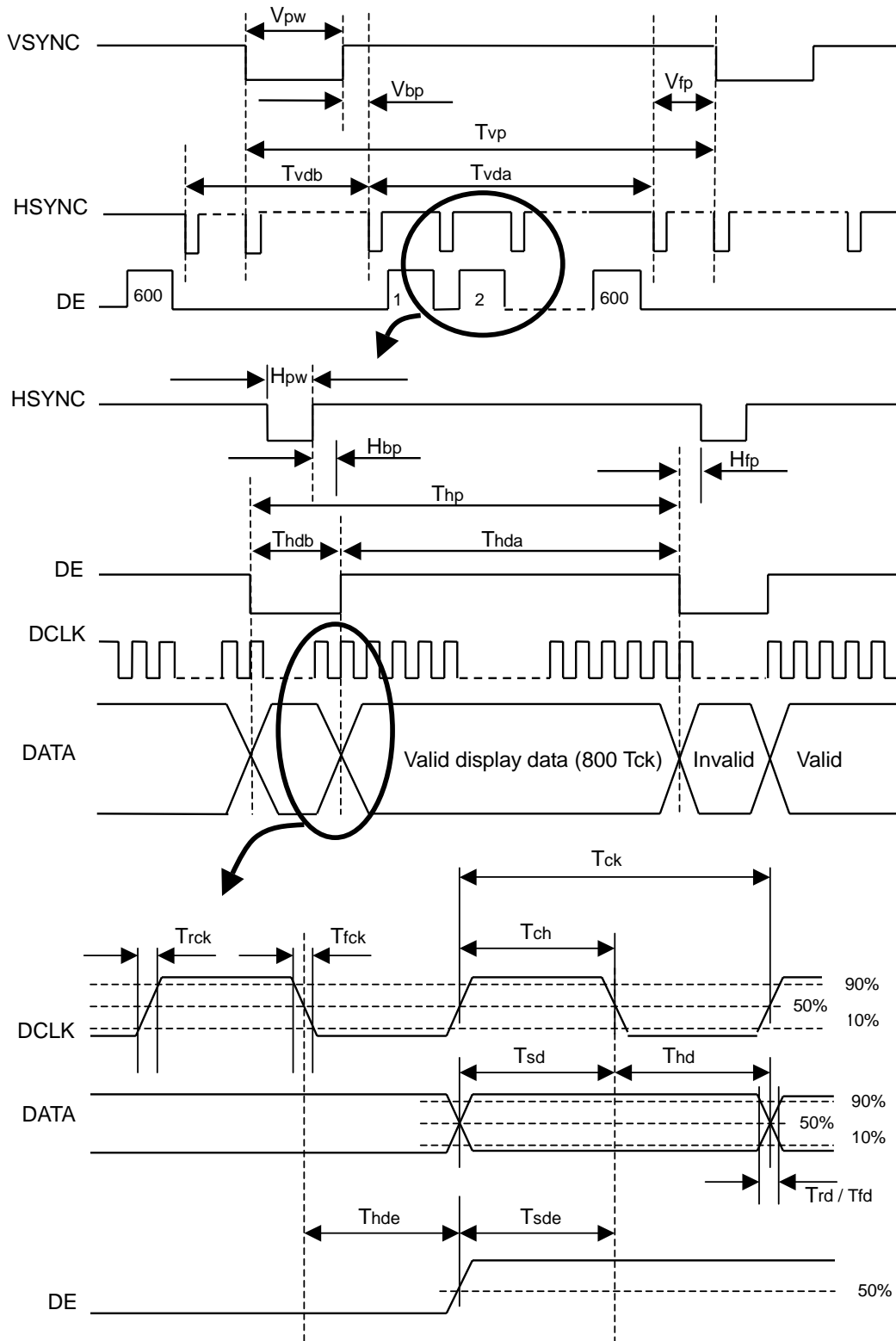

4.3 COLOR DATA INPUT ASSIGNMENT

Color		Data Signal																	
		Red						Green						Blue					
		R5	R4	R3	R2	R1	R0	G5	G4	G3	G2	G1	G0	B5	B4	B3	B2	B1	B0
Basic Colors	Black	0	0	0	0	0	0	0	0	0	0	0	0	0	0	0	0	0	0
	Red	1	1	1	1	1	1	0	0	0	0	0	0	0	0	0	0	0	0
	Green	0	0	0	0	0	0	1	1	1	1	1	1	0	0	0	0	0	0
	Blue	0	0	0	0	0	0	0	0	0	0	0	0	1	1	1	1	1	1
	Cyan	0	0	0	0	0	0	1	1	1	1	1	1	1	1	1	1	1	1
	Magenta	1	1	1	1	1	1	0	0	0	0	0	0	1	1	1	1	1	1
	Yellow	1	1	1	1	1	1	1	1	1	1	1	1	0	0	0	0	0	0
	White	1	1	1	1	1	1	1	1	1	1	1	1	1	1	1	1	1	1
Gray Scale Of Red	Red(0) / Dark	0	0	0	0	0	0	0	0	0	0	0	0	0	0	0	0	0	0
	Red(1)	0	0	0	0	0	1	0	0	0	0	0	0	0	0	0	0	0	0
	Red(2)	0	0	0	0	1	0	0	0	0	0	0	0	0	0	0	0	0	0
	:	:	:	:	:	:	:	:	:	:	:	:	:	:	:	:	:	:	:
	:	:	:	:	:	:	:	:	:	:	:	:	:	:	:	:	:	:	:
	Red(61)	1	1	1	1	0	1	0	0	0	0	0	0	0	0	0	0	0	0
	Red(62)	1	1	1	1	1	0	0	0	0	0	0	0	0	0	0	0	0	0
	Red(63)	1	1	1	1	1	1	0	0	0	0	0	0	0	0	0	0	0	0
Gray Scale Of Green	Green(0) / Dark	0	0	0	0	0	0	0	0	0	0	0	0	0	0	0	0	0	0
	Green(1)	0	0	0	0	0	0	0	0	0	0	0	1	0	0	0	0	0	0
	Green(2)	0	0	0	0	0	0	0	0	0	0	1	0	0	0	0	0	0	0
	:	:	:	:	:	:	:	:	:	:	:	:	:	:	:	:	:	:	:
	:	:	:	:	:	:	:	:	:	:	:	:	:	:	:	:	:	:	:
	Green(61)	0	0	0	0	0	0	1	1	1	1	0	1	0	0	0	0	0	0
	Green(62)	0	0	0	0	0	0	1	1	1	1	1	0	0	0	0	0	0	0
	Green(63)	0	0	0	0	0	0	1	1	1	1	1	1	0	0	0	0	0	0
Gray Scale Of Blue	Blue(0) / Dark	0	0	0	0	0	0	0	0	0	0	0	0	0	0	0	0	0	0
	Blue(1)	0	0	0	0	0	0	0	0	0	0	0	0	0	0	0	0	0	1
	Blue(2)	0	0	0	0	0	0	0	0	0	0	0	0	0	0	0	0	1	0
	:	:	:	:	:	:	:	:	:	:	:	:	:	:	:	:	:	:	:
	:	:	:	:	:	:	:	:	:	:	:	:	:	:	:	:	:	:	:
	Blue(61)	0	0	0	0	0	0	0	0	0	0	0	0	1	1	1	1	0	1
	Blue(62)	0	0	0	0	0	0	0	0	0	0	0	0	1	1	1	1	1	0
	Blue(63)	0	0	0	0	0	0	0	0	0	0	0	0	1	1	1	1	1	1

4.4 POWER UP/DOWN SEQUENCE

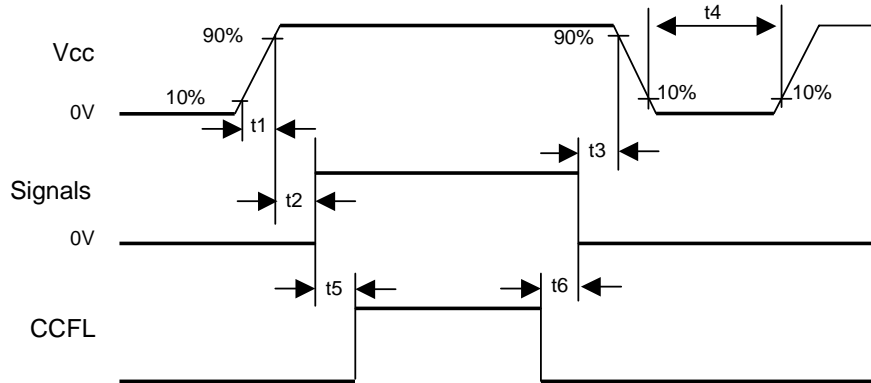

Timing Specifications:

$$0 \leq t1 \leq \text{TBD}$$

$$0 \leq t2 \leq \text{TBD}$$

$$0 \leq t3 \leq \text{TBD}$$

$$t4 \geq \text{TBD}$$

$$t5 \geq \text{TBD}$$

$$t6 \geq \text{TBD}$$

Notes: (1) Please avoid floating state of interface signal at invalid period.

(2) When the interface signal is invalid, be sure to pull down the power supply for LCD Vcc to 0V.

5. OPTICAL CHARACTERISTICS

5.1 TEST CONDITIONS

Item	Symbol	Value	Unit
Ambient Temperature	Ta	25±2	°C
Ambient Humidity	Ha	50±10	%RH
Supply Voltage	V _{CC}	3.3	V
Input Signal	According to typical value in "Electrical Characteristics"		
Inverter Current	I _L	4.3	mA
Inverter Driving Frequency	F _L	(55)	K Hz
Inverter		TBD	

The measuring method is shown in 5.2. The following items are measured under stable conditions about 20 minutes after the module works. The optical characteristics should be measured under lamp current I_L = 6.0 mA and in a dark environment (≤ 2 lux) or equivalent state with the methods shown in Note (6).

5.2 OPTICAL SPECIFICATIONS

Item	Symbol	Conditions	Min.	Typ.	Max.	Unit	Note	
Contrast Ratio	CR	$\theta_x=0^\circ, \theta_y=0^\circ$ Viewing Normal Angle	(150)	(200)	-	-	(2),(5)	
Response Time	T _R		-	(15)	(30)	ms	(3)	
	T _F		-	(35)	(50)	ms		
Average Luminance of White	L _{Ave}		TBD	(150)	-	cd/m ²	(4),(5)	
White Variation	δW		-	(1.4)	(1.6)	-	(5),(6)	
Color Chromaticity	Red		Rx		TBD		-	(1),(5)
			Ry		TBD		-	
	Green		Gx		TBD		-	
			Gy		TBD		-	
	Blue		Bx		TBD		-	
		By		TBD		-		
White	Wx		(0.31)		-			
	Wy		(0.33)		-			
Viewing Angle	Horizontal	θ_{x+}	(40)	(45)	-	Deg.		
		θ_{x-}	(40)	(45)	-			
	Vertical	θ_{y+}	(10)	(15)	-			
		θ_{y-}	(30)	(35)	-			

Note (1) Definition of Viewing Angle (θ_x, θ_y):

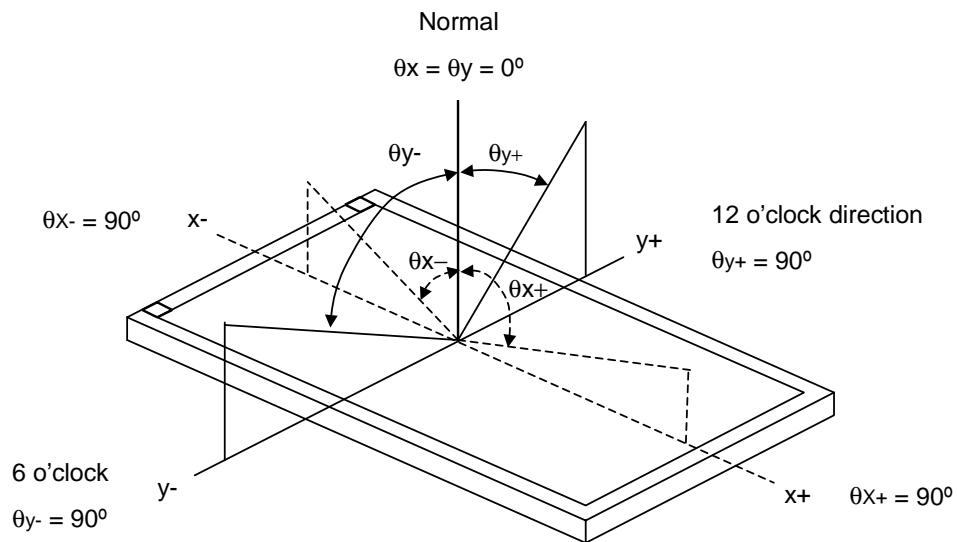

Note (2) Definition of Contrast Ratio (CR):

The contrast ratio can be calculated by the following expression.

$$\text{Contrast Ratio (CR)} = L_{63} / L_0$$

L63: Luminance of gray level 63

L 0: Luminance of gray level 0

$$\text{CR} = \text{CR} (5)$$

CR (X) is corresponding to the Contrast Ratio of the point X at Figure in Note (6).

Note (3) Definition of Response Time (T_R, T_F):

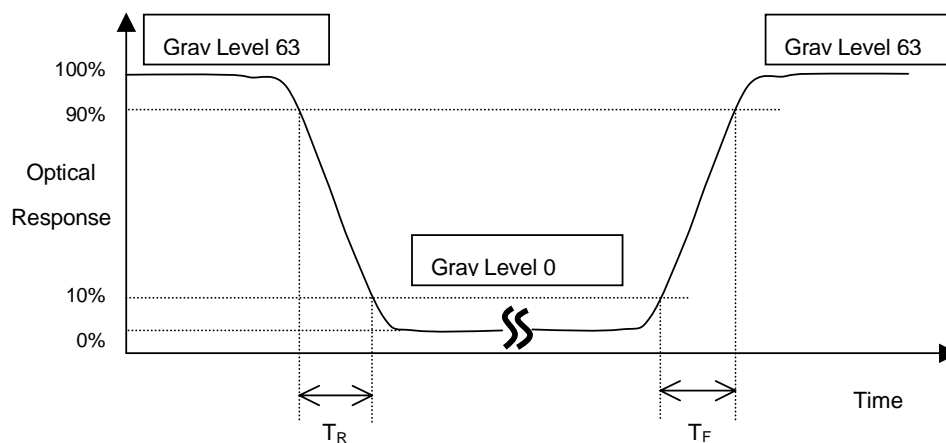

Note (4) Definition of Average Luminance of White (L_{AVE}):

Measure the luminance of gray level 63 at 5 points

$$L_{AVE} = [L (1)+ L (2)+ L (3)+ L (4)+ L (5)] / 5$$

L (x) is corresponding to the luminance of the point X at Figure in Note (6).

Note (5) Measurement Set-Up:

The LCD module should be stabilized at a given temperature for 20 minutes to avoid abrupt temperature change during measuring. In order to stabilize the luminance, the measurement should be executed after lighting Backlight for 20 minutes in a windless room.

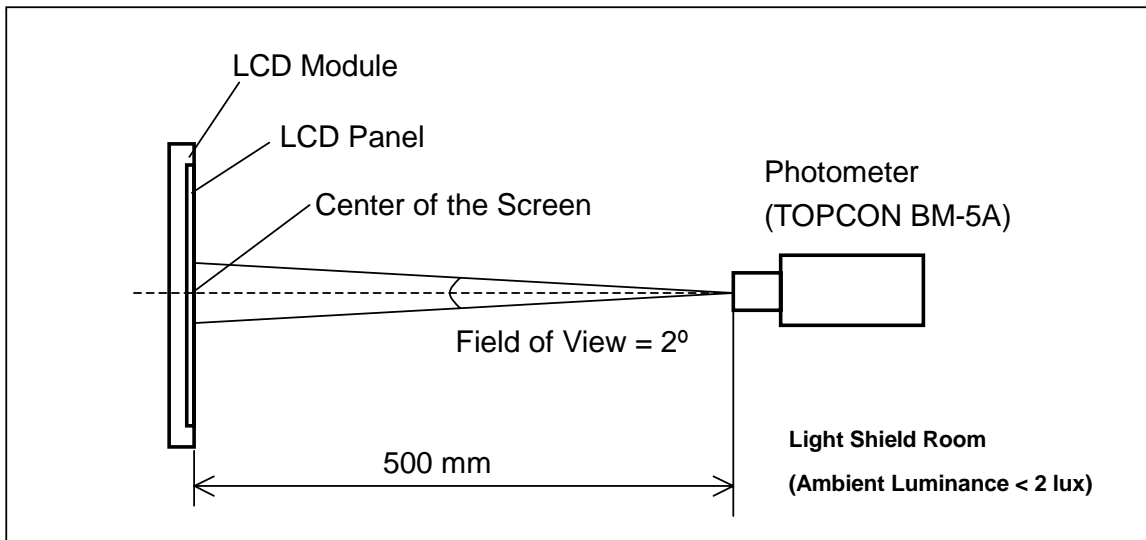

Note (6) Definition of White Variation (δW):

Measure the luminance of gray level 63 at 5 points

$$\delta W = \text{Maximum} [L (1), L (2), L (3), L (4), L (5)] / \text{Minimum} [L (1), L (2), L (3), L (4), L (5)]$$

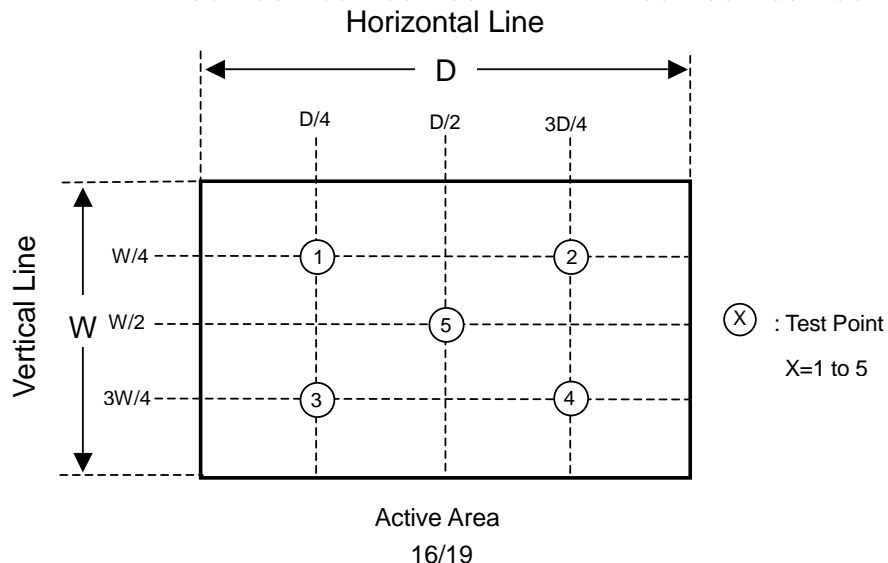

6. MECHANICAL DRAWING

Please refer to the attached drawings.

7. PRECAUTION

7. 1 ASSEMBLY AND HANDLING PRECAUTION

- (1) Do not apply rough force such as bending or twisting to the module during assembly.
- (2) To assemble or install module into user's system can be only in clean working areas. The dust and oil may cause electrical short or worsen the polarizer.
- (3) It's not permitted to have pressure or impulse on the module because the LCD panel and Backlight will be damaged.
- (4) Always follow the correct power sequence when LCD module is connecting and operating. This can prevent damage to the CMOS LSI chips during latch-up.
- (5) Do not pull the I/F connector in or out while the module is operating.
- (6) Do not disassemble the module.
- (7) Use a soft dry cloth without chemicals for cleaning, because the surface of polarizer is very soft and easily scratched.
- (8) It is dangerous that moisture come into or contacted the LCD module, because moisture may damage LCD module when it is operating.
- (9) High temperature or humidity may reduce the performance of module. Please store LCD module within the specified storage conditions.
- (10)When ambient temperature is lower than 10°C may reduce the display quality. For example, the response time will become slowly, and the starting voltage of CCFL will be higher than room temperature.

7.2 SAFETY PRECAUTION

- (1) The start-up voltage of Backlight is approximately 1000 Volts. It may cause electrical shock while assembling with inverter. Do not disassemble the module or insert anything into the Backlight unit.
- (2) If the liquid crystal material leaks from the panel, it should be kept away from the eyes or mouth. In case of contact with hands, skin or clothes, it has to be washed away thoroughly with soap.
- (3) After the module's end of life, it is not harmful in case of normal operation and storage.

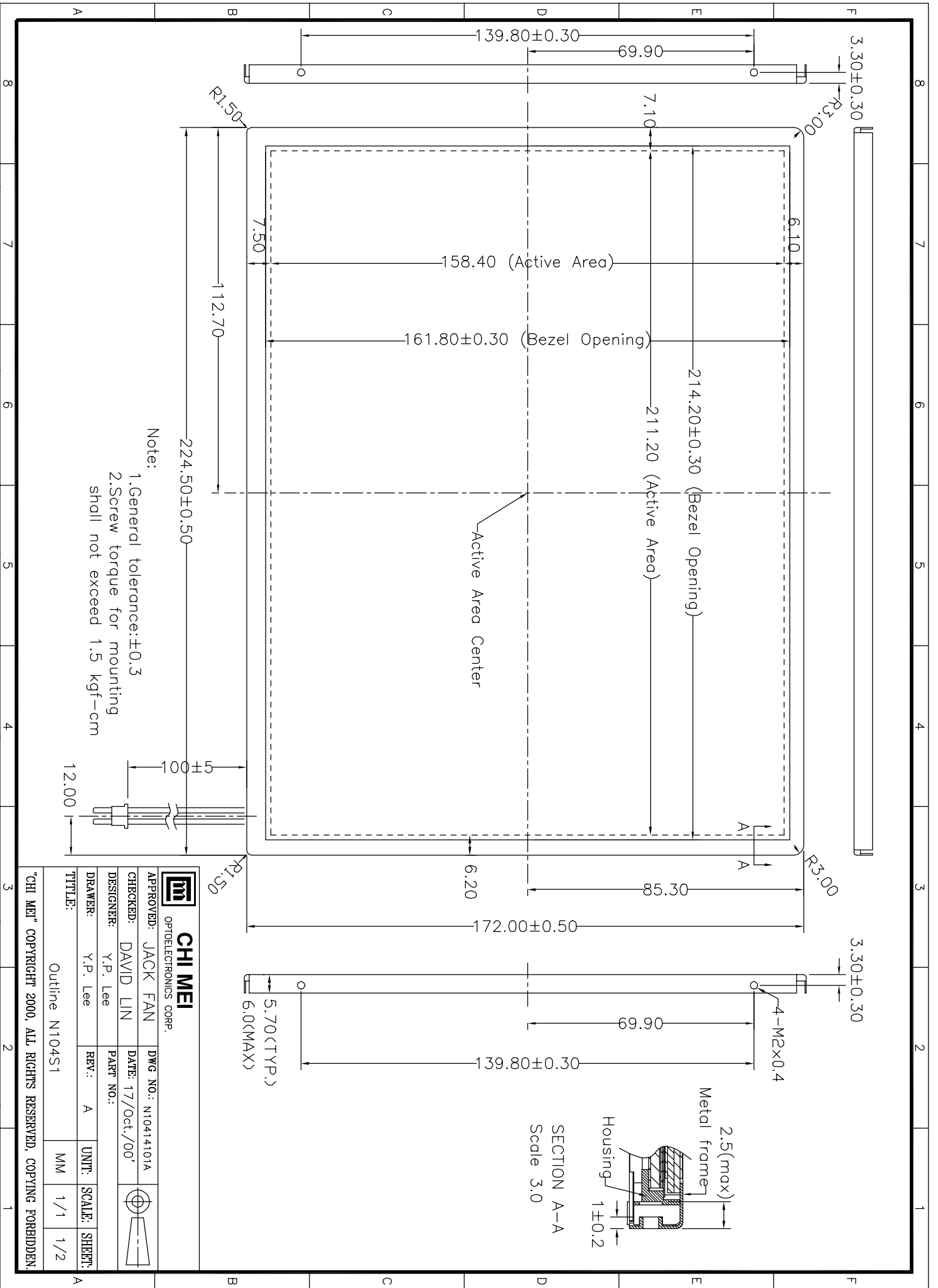

CHI MEI
OPTOELECTRONICS CORP.

APPROVED: JACK FAN DWG NO.: N10414101A

CHECKED: DAVID LIN DATE: 17/Oct./00

DESIGNER: Y.P. Lee PART NO.:

DRAWER: Y.P. Lee REV.: A UNIT: SCALE: SHEET:

TITLE: Outline N104S1 MM 1/1 1/2

"CHI MEI" COPYRIGHT 2000, ALL RIGHTS RESERVED, COPYING FORBIDDEN.

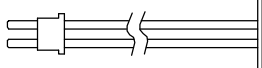
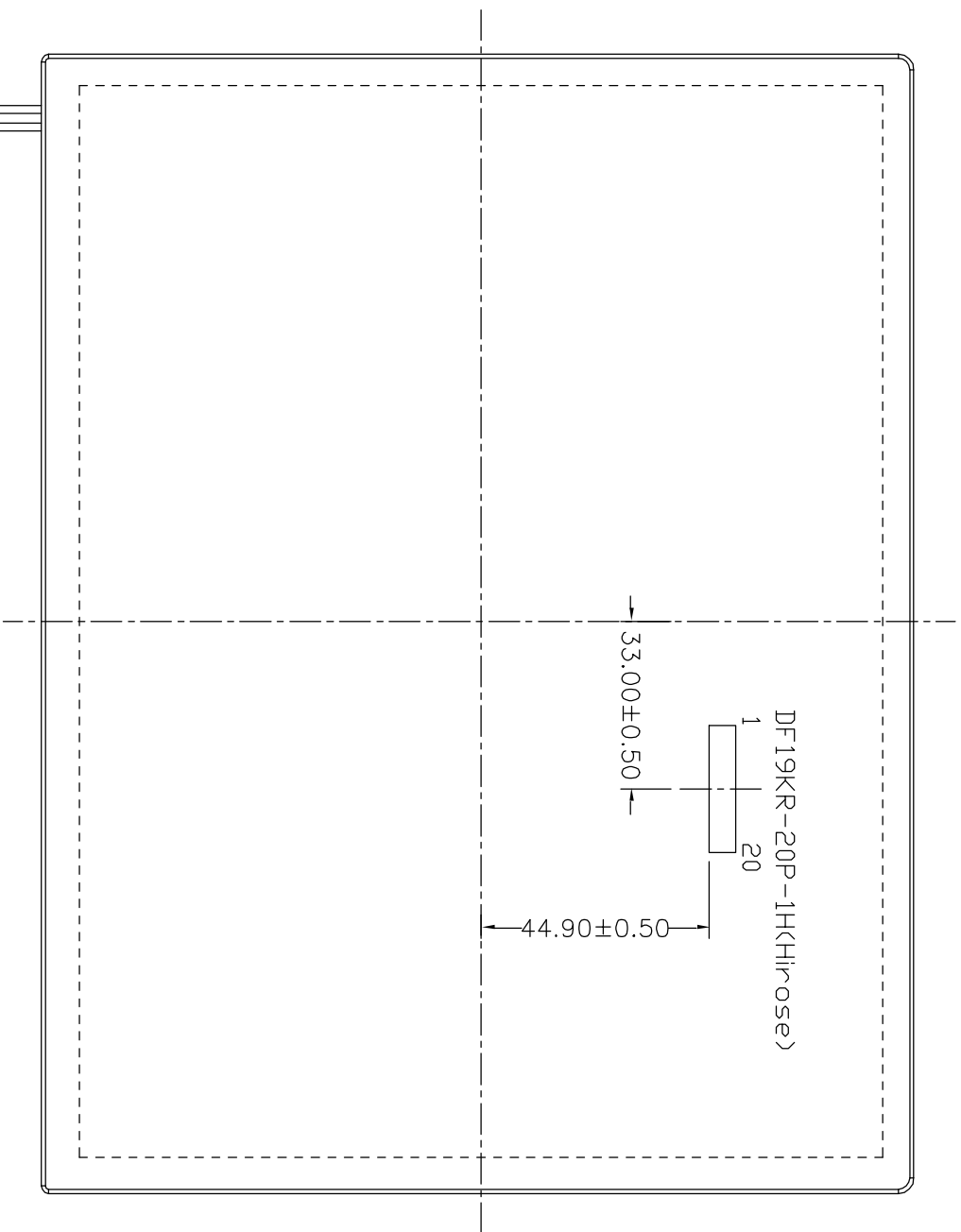

CHI MEI

OPTOELECTRONICS CORP.

APPROVED: JACK FAN DWG NO.: N10414101A

CHECKED: DAVID LIN DATE: 17/Oct./00'

DESIGNER: Y.P. Lee PART NO.:

DRAWER: Y.P. Lee REV.: A

TITLE: Outline N104S1

UNIT:	MM
SCALE:	1/1
SHEET:	2/2



"CHI MEI" COPYRIGHT 2000. ALL RIGHTS RESERVED. COPYING FORBIDDEN.