

**VI TELEFILTER****Filter Specification****TFS 360F1****1/5****Measurement condition**

Ambient temperature: 23 °C  
 Input power level: 0 dBm  
 Terminating impedances  
   for input: 580 Ohm // -0.85 pF  
   for output: 580 Ohm // -0.85 pF  
 Coupling coil: 91 nH

**Characteristics****Remark:**

Reference level for the relative attenuation  $a_{rel}$  of the TFS360F1 is the minimum of the pass band attenuation  $a_{min}$ . The minimum of the pass band attenuation  $a_{min}$  is defined as the insertion loss  $a_e$ . The centre frequency  $f_c$  is the arithmetic mean value of the upper and lower frequencies at the 1.5 dB filter attenuation level relative to the insertion loss  $a_e$ . The nominal frequency  $f_N$  is fixed on 360 MHz without tolerance. The given values for the relative attenuation  $a_{rel}$  and for the group delay ripple have to be reached at the frequencies given below also if the centre frequency  $f_c$  is shifted due to the temperature coefficient of frequency  $TC_f$  in the operating temperature range and due to a production tolerance for the centre frequency  $f_c$ .

<b>D a t a</b>		<b>typ. value</b>	<b>tolerance/limit</b>
<b>Insertion loss</b> (Reference level)	$a_e = a_{min}$	3,3 dB	max. 5,0 dB
<b>Nominal frequency</b>	$f_N$	-	360,00 MHz
<b>Centre frequency</b>	$f_c$	360,03 MHz	
<b>Pass band ripple</b>	$f_N \pm 67,7\text{kHz}$ BW	-	max. 1,5 dB
<b>Relative attenuation</b>	$a_{rel}$		
$f_N \pm 0,4$ MHz... $f_N \pm 0,6$ MHz		36...53 dB	min. 29 dB
$f_N \pm 0,6$ MHz... $f_N \pm 0,8$ MHz		53 dB	min. 42 dB
$f_N - 0,8$ MHz... $f_N - 3,0$ MHz		57...62 dB	min. 50 dB
$f_N - 3,0$ MHz... $f_N - 57$ MHz		60...65 dB	min. 52 dB
$f_N - 57$ MHz... $f_N - 77$ MHz		53...65 dB	min. 49 dB
$f_N - 77$ MHz... $f_N - 115$ MHz		65...75 dB	min. 52 dB
$f_N + 0,8$ MHz... $f_N + 1,6$ MHz *)		54 dB	min. 50 dB
$f_N + 1,6$ MHz... $f_N + 3,0$ MHz		56 dB	min. 45 dB
$f_N + 3,0$ MHz... $f_N + 115$ MHz		58...70 dB	min. 52 dB
<b>Group delay ripple</b>	GD		
$f_N \pm 67,76$ kHz		0.5 $\mu$ s	max. 2,0 $\mu$ s
<b>Input power level</b>		-	max. 5 dBm
<b>Operating temperature range</b>			- 35 °C ... + 95 °C
<b>Storage temperature range</b>			- 35 °C ... + 95 °C
<b>Temperature coefficient of frequency</b>	TC	- 0.036 ppm/K <sup>2</sup>	
<b>Frequency inversion temperature</b>		+ 20 °C	

\*) One distortion with a 3 dB bandwidth of less than 60 kHz and a relative attenuation of more than 46 dB is allowed.

**Generated:** \_\_\_\_\_

**Checked / approved:** \_\_\_\_\_

**VI TELEFILTER**  
 Potsdamer Straße 18  
 D 14 513 TELTOW / Germany  
 Tel: (+49) 3328 4784-0 / Fax: (+49) 3328 4784-30  
 E-Mail: [tft@telefilter.com](mailto:tft@telefilter.com)

**Vectron International Inc.**  
 267 Lowell Road  
 Hudson, NH 03051 / USA  
 Tel: (603) 598-0070 Fax: (603) 598-0075  
 E-Mail: [vti@vtinh.com](mailto:vti@vtinh.com)

VI TELEFILTER reserves the right to make changes to the product(s) and/or information contained herein without notice. No liability is assumed as a result of their use or application. No rights under any patent accompany the sale of any such product(s) or information.

**Construction, pin configuration and 50 Ω - matching network**

(All dimensions in mm)

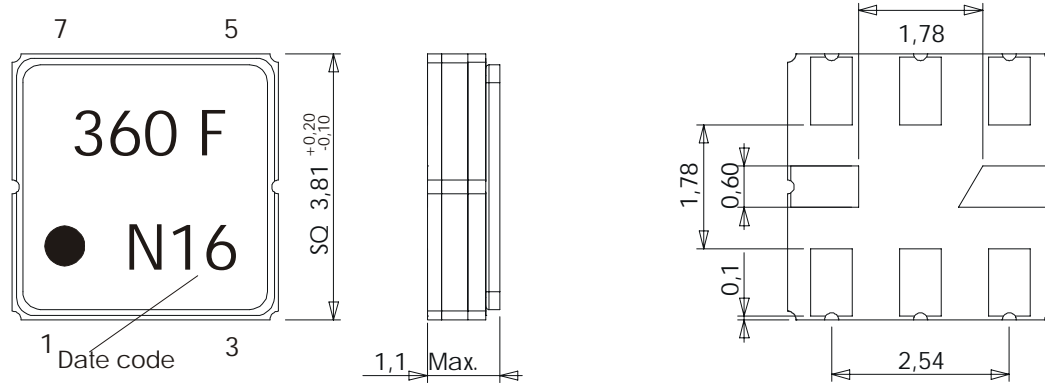

Pin 1	Sym. Output	Pin 5	Sym. Input
Pin 2	Sym. Output	Pin 6	Sym. Input
Pin 3	External Coil	Pin 7	Ground
Pin 4	Package Ground	Pin 8	Package ground

Date code:	Year + week
L	1999
M	2000
N	2001
...	

**50 Ohm Test circuit 1**

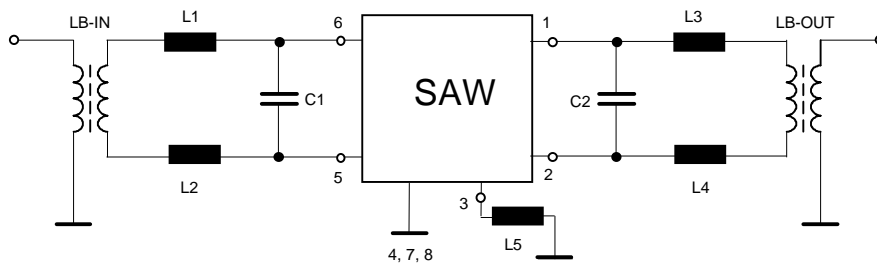

**50 Ohm Test circuit 2**

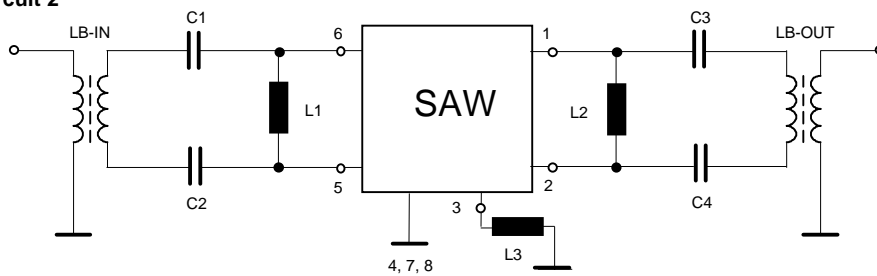

**VI TELEFILTER**  
 Potsdamer Straße 18  
 D 14 513 TELTOW / Germany  
 Tel: (+49) 3328 4784-0 / Fax: (+49) 3328 4784-30  
 E-Mail: [tft@telefilter.com](mailto:tft@telefilter.com)

**Vectron International Inc.**  
 267 Lowell Road  
 Hudson, NH 03051 / USA  
 Tel: (603) 598-0070 Fax: (603) 598-0075  
 E-Mail: [vti@vtinh.com](mailto:vti@vtinh.com)

VI TELEFILTER reserves the right to make changes to the product(s) and/or information contained herein without notice. No liability is assumed as a result of their use or application. No rights under any patent accompany the sale of any such product(s) or information.

**Stability Characteristics**

After the following tests the filter shall meet the whole specification:

1. Shock: 500g, 18 ms, half sine wave, 3 shocks each plane;  
DIN IEC 68 T2 - 27
2. Vibration: 10 Hz to 500 Hz, 0,35 mm or 5g respectively, 1 octave per min, 10 cycles per plan, 3 plans;  
DIN IEC 68 T2 - 6
3. Damp heat: 25 °C to 55°C / 95% r.H. / 10 cycles  
(cycle) DIN IEC 68 - 2 – 30 Db
4. Resistance to solder heat (reflow): max. 2 times reflow process;  
for temperature conditions refer to the attached "Air reflow temperature conditions" on page 4;

**Packing**

Tape & Reel: IEC 286 - 3, with exception of value for N and minimum bending radius;  
tape type II, embossed carrier tape with top cover tape on the upper side;

max. pieces of filters per reel: 3000  
reel of empty components at start: min 300 mm  
reel of empty components at start including leader: min 500 mm  
trailer: min 300 mm

**Tape (all dimensions in mm)**

W : 12 ± 0,3  
Po : 4 ± 0,1  
Do : 1,5 + 0,1  
E : 1,75 ± 0,1  
F : 5,5 ± 0,05  
G (min) : 0,75  
P2 : 2 ± 0,05  
P1 : 8 ± 0,1  
D1(min) : 1,5  
Ao : 4,3 ± 0,1  
Bo : 4,3 ± 0,1  
CT : 9,5 ± 0,1

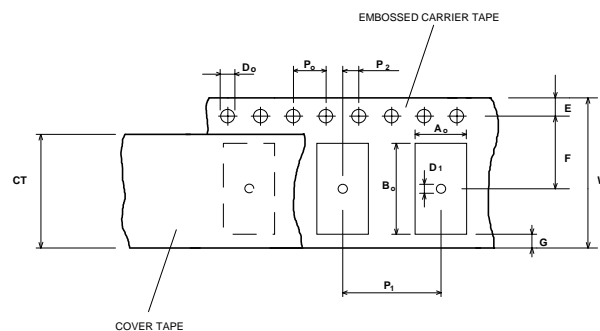
**Reel (all dimensions in mm):**

A : 330  
W1 : 12,4 + 0,2  
W2 (max) : 18,4  
N (min) : 50  
C : 13 ± 0,2

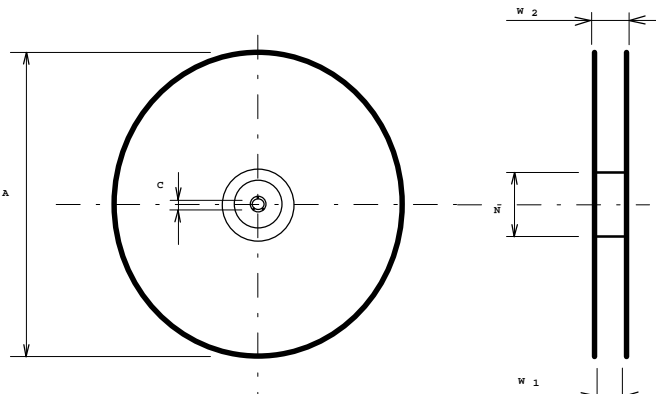

The minimum bending radius is 45 mm. The mounting surface of the filters faces the bottom side of the embossed carrier tape. The marking of the filters is able to read if the view is directed on the upper side of the carrier tape with the sprocket holes on the right side of the tape.

**VI TELEFILTER**  
Potsdamer Straße 18  
D 14 513 TELTOW / Germany  
Tel: (+49) 3328 4784-0 / Fax: (+49) 3328 4784-30  
E-Mail: [tft@telefilter.com](mailto:tft@telefilter.com)

**Vectron International Inc.**  
267 Lowell Road  
Hudson, NH 03051 / USA  
Tel: (603) 598-0070 Fax: (603) 598-0075  
E-Mail: [vti@vtinh.com](mailto:vti@vtinh.com)

VI TELEFILTER reserves the right to make changes to the product(s) and/or information contained herein without notice. No liability is assumed as a result of their use or application. No rights under any patent accompany the sale of any such product(s) or information.

**Air reflow temperature conditions**

1st and 2nd air reflow profile

<b>Name:</b>	pre-heating periods	main-heating periods	peak temperature
<b>Temperature:</b>	150 °C - 170 °C	over 200 °C	255 °C ± 5 °C
<b>Time:</b>	60 sec. - 90 sec.	20 sec. - 25 sec.	

**Chip-mount air reflow profile**

Table for temperature vs. time during the air reflow process

Tolerance of temperatures: ± 5 °C

time / sec.	temperature / °C	time / sec.	temperature / °C
0	23	140	160
10	34	150	161
20	46	160	164
30	60	170	170
40	80	180	180
50	103	190	205
60	121	195	230
70	134	200	255
80	143	205	230
90	150	210	205
100	154	215	180
110	156	220	165
120	158	230	140
130	159	240	120

**VI TELEFILTER****Filter Specification****TFS 360F1****5/5****History**

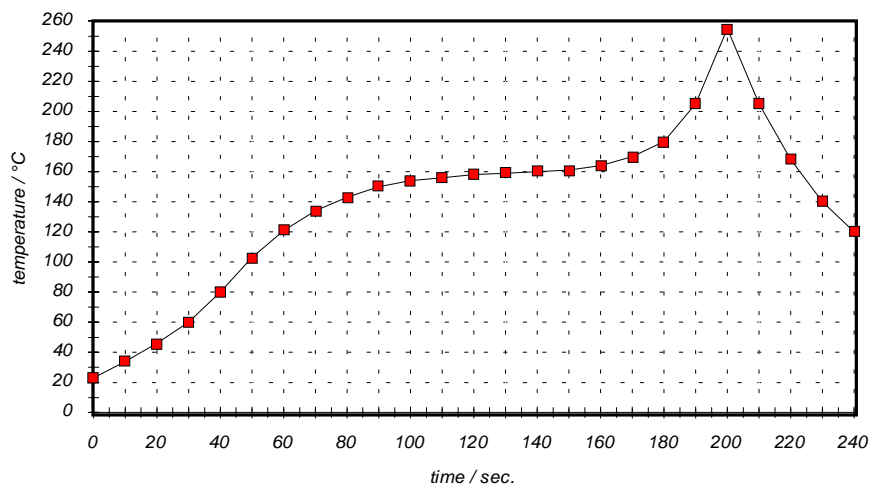
<b>Version</b>	<b>Reason of Changes</b>	<b>Name</b>	<b>Date</b>
1.0	- Generation of specification	Dr. Wall	22.08.2000
1.1	- Add values for termination impedance and coupling coil	Dr. Wall	28.08.2000
1.2	- Pin numbers in package drawing added - Tape and reel information added - Typical filter data added	Dr. Wall	18.10.2000
1.3	- Change values for termination impedances from 520 ohm // -0.85 pF to 580 Ohm // -0.85 pF.	Dr. Wall	27.11.2000
TFS360F1 1.4	- Increase operating temperature range. - Change storage temperature range. - Change value for typical centre frequency. - Change filter name to TFS360F1	Dr. Wall	18.04.2001

**VI TELEFILTER**  
**Potsdamer Straße 18**  
**D 14 513 TELTOW / Germany**  
**Tel: (+49) 3328 4784-0 / Fax: (+49) 3328 4784-30**  
**E-Mail: [tft@telefilter.com](mailto:tft@telefilter.com)**

**Vectron International Inc.**  
**267 Lowell Road**  
**Hudson, NH 03051 / USA**  
**Tel: (603) 598-0070 Fax: (603) 598-0075**  
**E-Mail: [vti@vtinh.com](mailto:vti@vtinh.com)**

VI TELEFILTER reserves the right to make changes to the product(s) and/or information contained herein without notice. No liability is assumed as a result of their use or application. No rights under any patent accompany the sale of any such product(s) or information.