

Low Profile Transceiver Module PIN Photodiode and Infrared Emitter

Description

The miniaturized TFDU2201 is an ideal PIN photodiode transmitter combination in a unique package for applications in telecommunications like mobile phones and pagers. The device is mechanically designed for lowest profile with a height of only 2.8 mm. The device is designed to be compatible to the IrDA standard when using an external receiver IC and IRED driver.

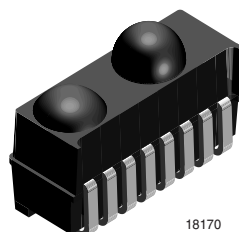

18170

Features

- Package dimension:
L 7.3 mm x W 4.55 mm x H 2.75 mm
- SMD side view
- Fast PIN Photodiode for SIR and FIR applications
- Detector with high efficiency and high speed at low bias voltage
- Only 30 mA IRED peak current during transmission for IrDA SIR low power standard
- Lead(Pb)-free device
- Device in accordance to RoHS 2002/95/EC and WEEE 2002/96/EC

Applications

- Mobile Phones, Pagers, Personal Digital Assistants (PDA)
- Handheld battery operated equipment

Parts Table

Part	Description	Qty / Reel
TFDU2201-TR1	Orientated in carrier tape for side view mounting	750 pcs.
TFDU2201-TR3	Orientated in carrier tape for side view mounting	2250 pcs.

Pin Description

Pin Number	Function	Description	I/O	Active
1	IRED GND	IRED cathode, ground, to be used as heat sink		
2	IRED GND	IRED cathode, ground, to be used as heat sink		
3	IRED Anode	IRED anode, to be driven by a current source		
4	NC			
5	NC			
6	NC			
7	D _{anode}	Detector anode		
8	D _{cathode}	Detector cathode		

Pinout

TFDU2201
weight 100 mg

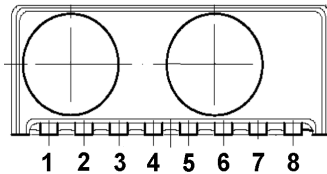

18228

Absolute Maximum Ratings

Parameter	Test Conditions	Symbol	Min	Typ.	Max	Unit
Photo pin diode, reverse voltage range		V_r	- 0.3		12	V
Photo pin diode, reverse photo current					10	mA
Average IRED current		$I_{\text{IRED(DC)}}$			100	mA
Repetitive pulsed IRED current	$< 90 \mu\text{s}, t_{\text{on}} < 20 \%$	$I_{\text{IRED(RP)}}$			550	mA
IRED, reverse voltage range		V_{rIRED}	- 0.3		5	V
Power dissipation	see Figure 3	P_{tot}			200	mW
Junction temperature		T_J			125	°C
Ambient temperature range (operating)		T_{amb}	- 25		+ 85	°C
Storage temperature range		T_{stg}	- 40		+ 85	°C
Soldering temperature	$t = 20 \text{ s @ } 215 \text{ °C}$, see Vishay Telefunken IrDA Design Guide			215	240	°C
Virtual source size	Method: $(1 - 1/e)$ encircled energy	d		2		mm

Compatible to Class 1 operation of IEC 60825 or EN60825 with worst case IrDA SIR pulse pattern, 115.2 kbit/s

Electrical Characteristics

Transceiver

Tested for the following parameters ($T = 25 \text{ °C}$, unless otherwise stated)

Parameter	Test Conditions	Symbol	Min	Typ.	Max	Unit
Supported data rates	base band		9.6		4000	kbit/s

Optoelectronic Characteristics

Receiver

Tested for the following parameters (T = 25 °C, unless otherwise stated)

Parameter	Test Conditions	Symbol	Min	Typ.	Max	Unit
Spectral sensitivity	$ \alpha \leq \pm 15^\circ$, $V_f = 2\text{ V}$, $\lambda = 875\text{ nm}$	S λ	1.0	1.2	1.8	nA/(mW/m ²)
Bias voltage range, detector		V _{Rev}			12	V
Reverse leakage current				0.2		nA
Spectral bandwidth		λ	800		950	nm
Max. operating irradiance	$ \alpha \leq \pm 90^\circ\text{C}$, $V_{CC} = 2\text{ V}$	E _{e, max}	8000	15000		W/m ²
Rise time @ load : R = 50 Ω	$V_f = 2\text{ V}$, $\lambda = 875\text{ nm}$	t _r		40		ns
Fall time @ load : R = 50 Ω	$V_f = 2\text{ V}$, $\lambda = 875\text{ nm}$	t _f		40		ns

Transmitter

Tested for the following parameters (T = 25 °C, unless otherwise stated)

Parameter	Test Conditions	Symbol	Min	Typ.	Max	Unit
Forward current operating condition for low power IrDA operation	I _e = 4 to 28 mW/sr in $ \alpha \leq \pm 15^\circ$	I _{F1}		30		mA
Output radiant intensity	$ \alpha \leq \pm 15^\circ$, I _{F1} = 35 mA, 25 % duty cycle	I _e	4	8	14	mW/sr
	$ \alpha \leq \pm 15^\circ$, I _{F1} = 350 mA, 25 % duty cycle	I _e	35			mW/sr
Forward voltage	I _f = 50 mA	V _f	1.2		1.45	V
Peak emission wavelength		λ_p	880		900	nm
Spectral emission bandwidth				45		nm
Optical rise/fall time	2 MHz square wave signal (duty cycle 1 : 1)			38		ns

Recommended Solder Profile

Solder Profile for Sn/Pb soldering

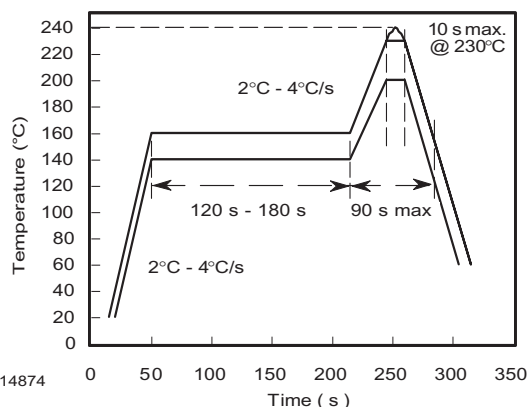

Figure 1. Recommended Solder Profile for Sn/Pb soldering

Lead-Free, Recommended Solder Profile

The TFDU2201 is a lead-free transceiver and qualified for lead-free processing. For lead-free solder paste like Sn_(3.0-4.0)Ag_(0.5-0.9)Cu, there are two standard reflow profiles: Ramp-Soak-Spike (RSS) and Ramp-To-Spike (RTS). The Ramp-Soak-Spike profile was developed primarily for reflow ovens heated by infrared radiation. With widespread use of forced convection reflow ovens the Ramp-To-Spike profile is used increasingly. Shown below in figure 2 is Vishay's recommended profile for use with the TFDU2201 transceivers. For more details please refer to Application note: SMD Assembly Instruction.

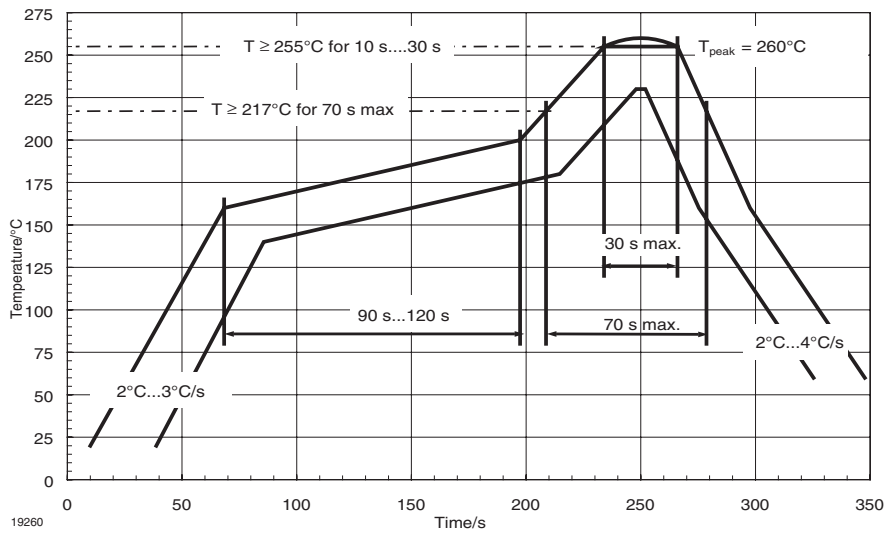

Figure 2. Solder Profile, RSS Recommendation

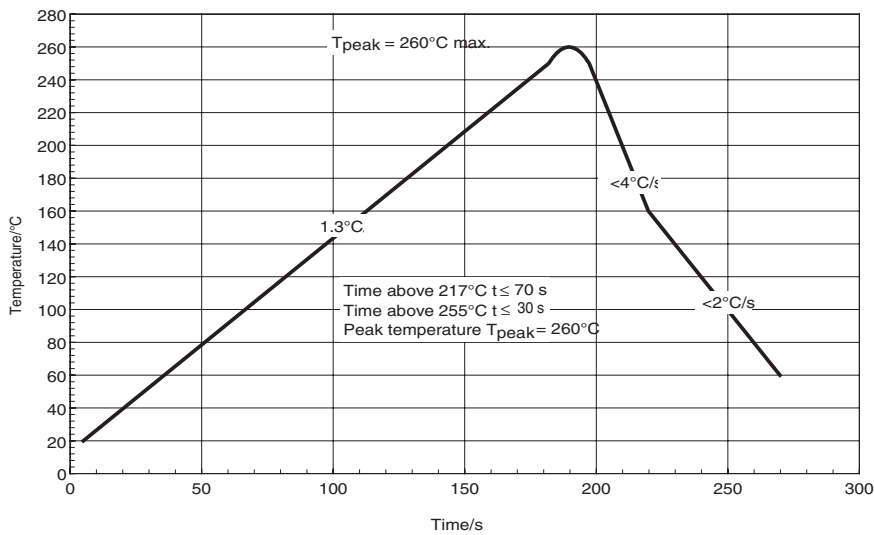

Figure 3. RTS Recommendation

A ramp-up rate less than 0.9°C/s is not recommended. Ramp-up rates faster than 1.3°C/s could damage an optical part because the thermal conductivity is less than compared to a standard IC.

Current Derating Diagram

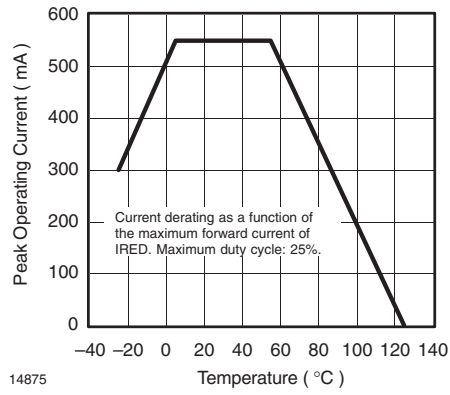
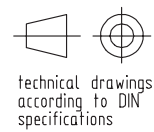
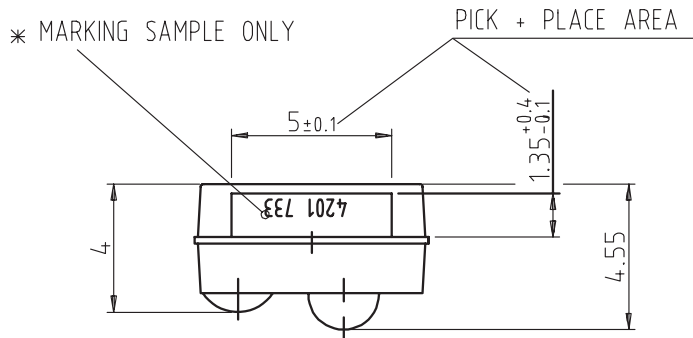
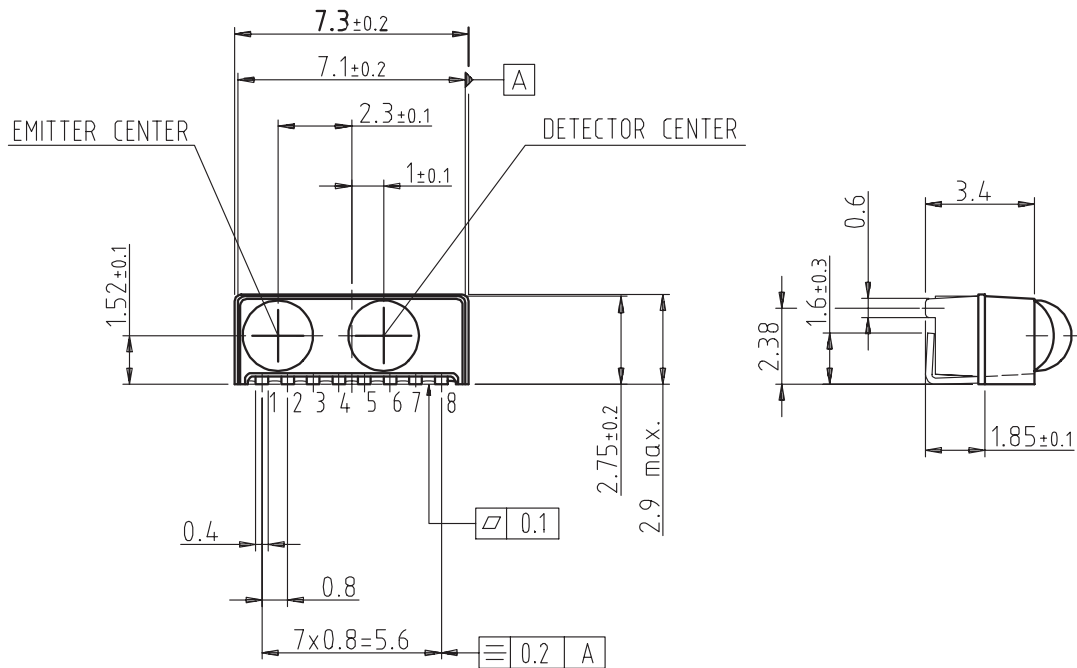
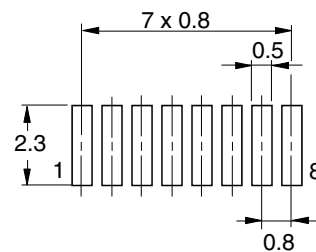

Figure 4. Current Derating Diagram

Package Dimensions in mm



* MARKING ORIENTATION
180 DEGREES ALLOWED



14484

Reel Dimensions

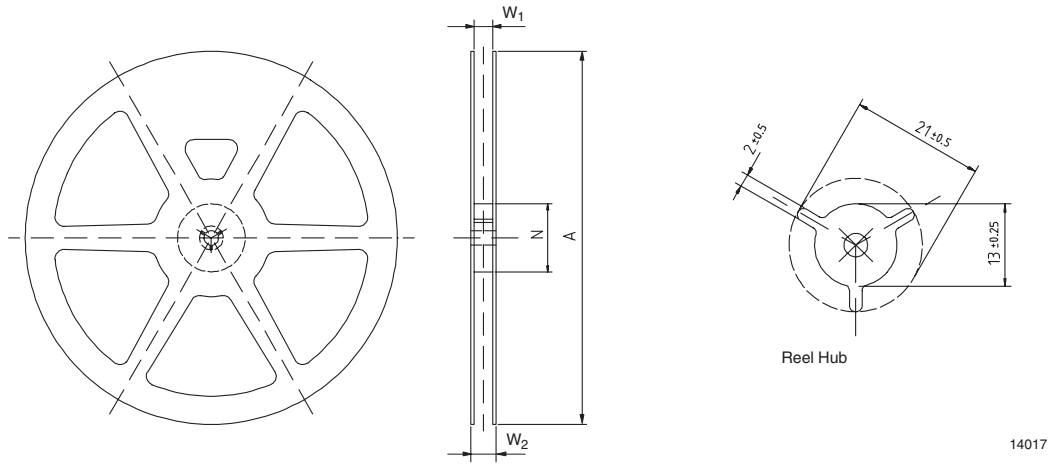

Tape Width	A max.	N	W ₁ min.	W ₂ max.	W ₃ min.	W ₃ max.
mm	mm	mm	mm	mm	mm	mm
24	330	60	24.4	30.4	23.9	27.4

Tape Dimensions in mm

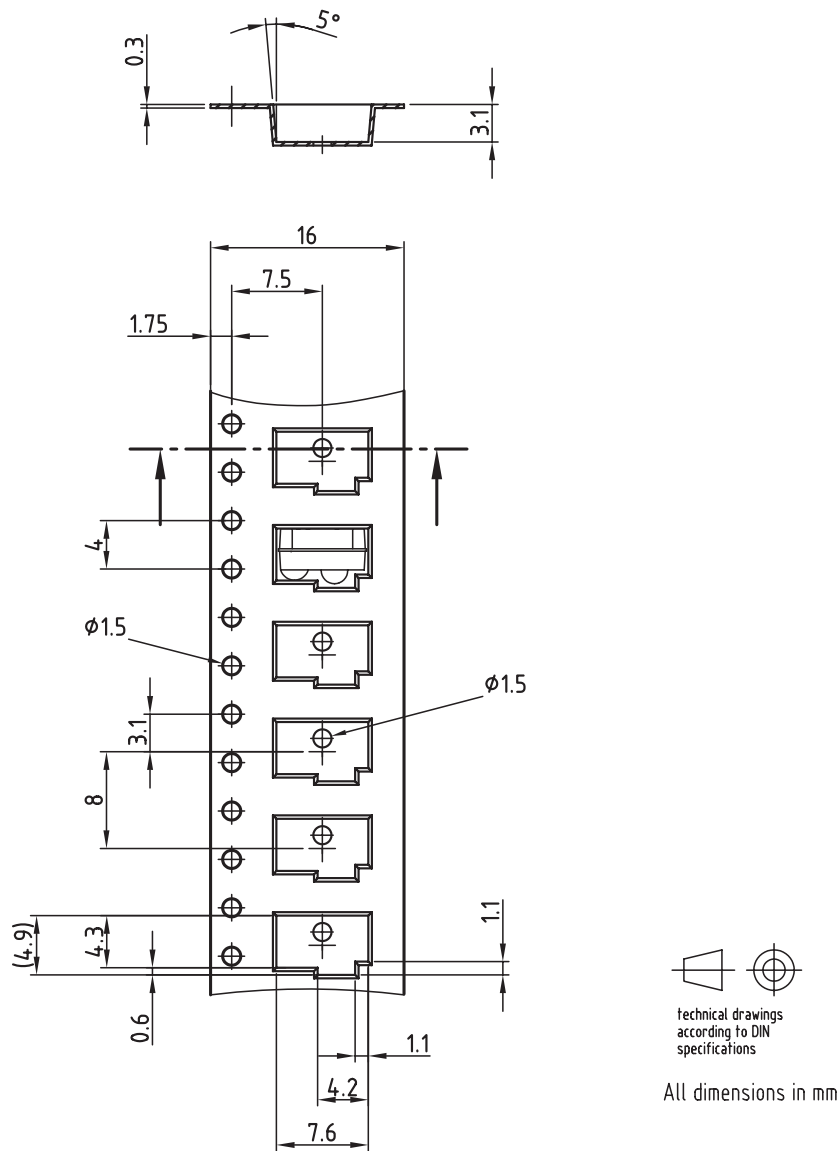

Drawing-No.: 9.700-5227.01-4
Issue: 3; 03.09.99

Drawing refers to following types: TFDU 4201

18258_1

Ozone Depleting Substances Policy Statement

It is the policy of Vishay Semiconductor GmbH to

1. Meet all present and future national and international statutory requirements.
2. Regularly and continuously improve the performance of our products, processes, distribution and operating systems with respect to their impact on the health and safety of our employees and the public, as well as their impact on the environment.

It is particular concern to control or eliminate releases of those substances into the atmosphere which are known as ozone depleting substances (ODSs).

The Montreal Protocol (1987) and its London Amendments (1990) intend to severely restrict the use of ODSs and forbid their use within the next ten years. Various national and international initiatives are pressing for an earlier ban on these substances.

Vishay Semiconductor GmbH has been able to use its policy of continuous improvements to eliminate the use of ODSs listed in the following documents.

1. Annex A, B and list of transitional substances of the Montreal Protocol and the London Amendments respectively
2. Class I and II ozone depleting substances in the Clean Air Act Amendments of 1990 by the Environmental Protection Agency (EPA) in the USA
3. Council Decision 88/540/EEC and 91/690/EEC Annex A, B and C (transitional substances) respectively.

Vishay Semiconductor GmbH can certify that our semiconductors are not manufactured with ozone depleting substances and do not contain such substances.

We reserve the right to make changes to improve technical design and may do so without further notice.

Parameters can vary in different applications. All operating parameters must be validated for each customer application by the customer. Should the buyer use Vishay Semiconductors products for any unintended or unauthorized application, the buyer shall indemnify Vishay Semiconductors against all claims, costs, damages, and expenses, arising out of, directly or indirectly, any claim of personal damage, injury or death associated with such unintended or unauthorized use.

Vishay Semiconductor GmbH, P.O.B. 3535, D-74025 Heilbronn, Germany
Telephone: 49 (0)7131 67 2831, Fax number: 49 (0)7131 67 2423